

MEDICAL PLATOON LEADERS' HANDBOOK TACTICS, TECHNIQUES, AND PROCEDURES

TABLE OF CONTENTS

			Page
Preface			iii
CHAPTER	1.	COMBAT ORGANIZATIONS	1-1
Section	I.	The Division	1-1
Section	II.	Types of Divisions	1-1
Section	III.	The Division Staff	1-6
Section	IV.	The Brigade	1-7
Section	V.	The Battalion	1-9
Section	VI.	The Battalion Staff	1-13
Section	VII.	The Divisional Armored Cavalry Squadron	1-17
CHAPTER	2.	THE ARMORED CAVALRY REGIMENT	2-1
Section	I.	Armored Cavalry Regiment	2-1
Section	II.	Regimental Armored Cavalry Squadron	2-1
Section	III.	Armored Cavalry Regiment Medical Company Division-Level Health Service Support	2-2
Section	IV.	Squadron (Unit) Level Health Service Support Armored Cavalry Squadron	2-3
CHAPTER	3.	THE HEALTH SERVICE SUPPORT SYSTEM	3-1
CHAPTER	4.	DIVISION-LEVEL HEALTH SERVICE SUPPORT	4-1
Section	I.	Division Support Command	4-1
Section	II.	Division Support Command—Command and Control	4-4
Section	III.	Division-Level Health Service Support Armored and Mechanized Infantry Division	4-6
Section	IV.	Division Level Health Service Support Light Infantry, Airborne, and Air Assault Division	4-16
Section	V.	Support Company Element	4-33
Section	VI.	Forward Support Medical Company	4-39
CHAPTER	5.	UNIT-LEVEL HEALTH SERVICE SUPPORT	5-1
Section	I.	Type Units Supported	5-1
Section	II.	Medical Platoon	5-1
Section	III.	Medical Sections and Special Purpose Medical Platoons	5-12
Section	IV.	Operating the Medical Platoons	5-22
Section	V.	Employment of the Medical Platoon	5-33

DISTRIBUTION RESTRICTION: Approved for public release; distribution unlimited.

CHAPTER	6.	HEALTH SERVICE SUPPORT IN TACTICAL OPERATIONS	6-1
Section	I.	Support of Offensive Operations	6-1
Section	II.	Support of Defensive Operations	6-6
Section	III.	Support Reserve Operations	6-11
Section	IV.	Support of Retrograde Operations	6-13
Section	V.	Support of Other Tactical Operations	6-16
Section	VI.	Special Operations	6-18
Section	VII.	Health Service Support in a Nuclear, Biological, Chemical, or Directed Energy Environment	6-27
APPENDIX	A.	TRAINING PROCEDURES GUIDE	A-1
APPENDIX	B.	COMBAT LIFESAVER	B-1
APPENDIX	C.	MEDICAL INTELLIGENCE	C-1
APPENDIX	D.	BATTALION AID STATION SPLIT TEAM OPERATIONS AND LOADING PLANS	D-1
APPENDIX	E.	PATIENT DECONTAMINATION PROCEDURES	E-1
APPENDIX	F.	EVACUATION REQUEST PROCEDURES	F-1
APPENDIX	G.	COMBAT TRAINING CENTERS LESSONS LEARNED	G-1
APPENDIX	H.	THE GENEVA CONVENTION	H-1
GLOSSARY		Glossary-1
REFERENCES		References-1
INDEX		Index-1

Preface

Purpose

This manual is directed to medical platoon leaders of combat and combat support battalions and cavalry squadrons. However, the manual applies equally to other medical platoon members in accomplishment of their mission. The tactics, techniques, and procedures provided are not all inclusive. They are presented as modes of operation. This manual provides a starting point from which users should develop or tailor techniques and procedures to fit their specific units.

Standardisation Agreements

This manual is in consonance with the following International Standardization Agreements:

TITLE	NATO STANAG
Procedures for Disposition of Allied Patients by Medical Installations	2061
Medical and Dental Supply Procedures	2128
Camouflage of the Geneva Emblem on Medical Facilities on Land	2931

Proponent

The proponent of this publication is the Academy of Health Sciences, US Army. Submit changes for improving this publication on DA Form 2028 (Recommended Changes to Publications and Blank Forms) and forward it to **Commandant, Academy of Health Sciences, US Army, ATTN: HSHA-TLD, Fort Sam Houston, Texas 78234-6100.**

Neutral Language

Unless this publication states otherwise, masculine nouns and pronouns do not refer exclusively to men.

Use of Trade or Brand Names

Use of trade or brand names in this publication is for illustrative purposes only, and does not imply endorsement by the Department of Defense.

CHAPTER 1

COMBAT ORGANIZATION**Section I. THE DIVISION****1-1. Background**

The division is the largest Army fixed organization that trains and fights as a tactical team. It is organized with varying numbers and types of combat, combat support (CS), and combat service support (CSS) units. A division may be armored, mechanized, motorized, infantry, light infantry, airborne, or air assault. It is a self-sustaining force capable of independent operations, even for long periods of time, when properly reinforced. Each type of division conducts tactical operations in a low-, mid-, or high-intensity combat environment. Divisions are the basic units of maneuver at the tactical level. The AirLand Battle is won or lost by the division integrated fight.

1-2. Role of the Division

Divisions plan future operations based on the echelons above corps (EAC) and corps commanders' intent; resources are then allocated based on battalion- and brigade-size units. Divisions defend against three or more assaulting enemy divisions. The defending division commander directs, coordinates, and supports operations of his brigades against assaulting regiments. The division interdicts follow-on regiments to disrupt and delay those forces as they attempt to join the battle. When attacking, the division commander directs, coordinates, and supports operations of his brigades against enemy battalions and regiments. The division interdicts deeper enemy echelons, reserves, and CS forces.

Section II. TYPE OF DIVISIONS**1-3. Armored and Mechanized Divisions**

The heavy division of the US Army (armored and mechanized) provide mobile, armor-protected firepower. Because of their mobility and survivability, the heavy divisions are employed over wide areas where they are afforded long-range and flat-trajectory fire. They destroy enemy armored forces and seize and control land areas, including populations and resources. During offensive operations, heavy divisions can rapidly concentrate overwhelming combat power to break through or envelop enemy defenses. They then strike to destroy fire support, command and control, and service support elements. Using mobility for rapid concentration to attack, reinforce, or to block, they defeat an enemy while economizing forces in other areas. Heavy divisions operate best in open terrain where they can use their mobility and long-range, direct-fire weapons to the best advantage (Figure 1-1).

1-4. Infantry Division

The infantry division is a combined arms force of maneuver, CS, and CSS units. It does not have the mechanized assets to close with the enemy's heavy forces in terrain suitable for mechanized operations; rather it is more effectively employed in terrain favoring dismounted operations, such as large urban areas, mountains, and jungles.

1-5. Light Infantry Division

a. The organization of the light infantry division provides the flexibility to accomplish missions on a global basis on different types of terrain and against a variety of enemy forces (Figure 1-2). It differs from the infantry and other divisions in both design and concept of employment.

b. The light infantry division is the most rapidly and strategically deployable of the various

types of US divisions; it is organized to fight as part of a larger force; in conventional conflicts; or independently in a low-intensity conflict (LIC). The ability of the light infantry division command and control structure to readily accept augmentation forces permits task organizing for any situation from low- to high-intensity conflicts. The factors of METT-T (mission, enemy, terrain, troops, and time available) will determine the augmentations required for the division.

c. Although employed as an entity, the light division method of operation is to disperse widely in the area of operations; conduct synchronized, but decentralized operations primarily at night or

during periods of limited visibility. Mass is achieved through the combined effects of synchronized, small-unit operations and fires. Physical concentration (massing) of light division forces only occurs when the risk is low and the payoff is high.

d. At the tactical level, the optimum employment option is to employ the light force as a division under corps control. The corps commander must ensure that the mission assigned to the light force capitalizes on its capabilities. The light division conducts operations exploiting the advantages of restricted terrain and limited visibility.

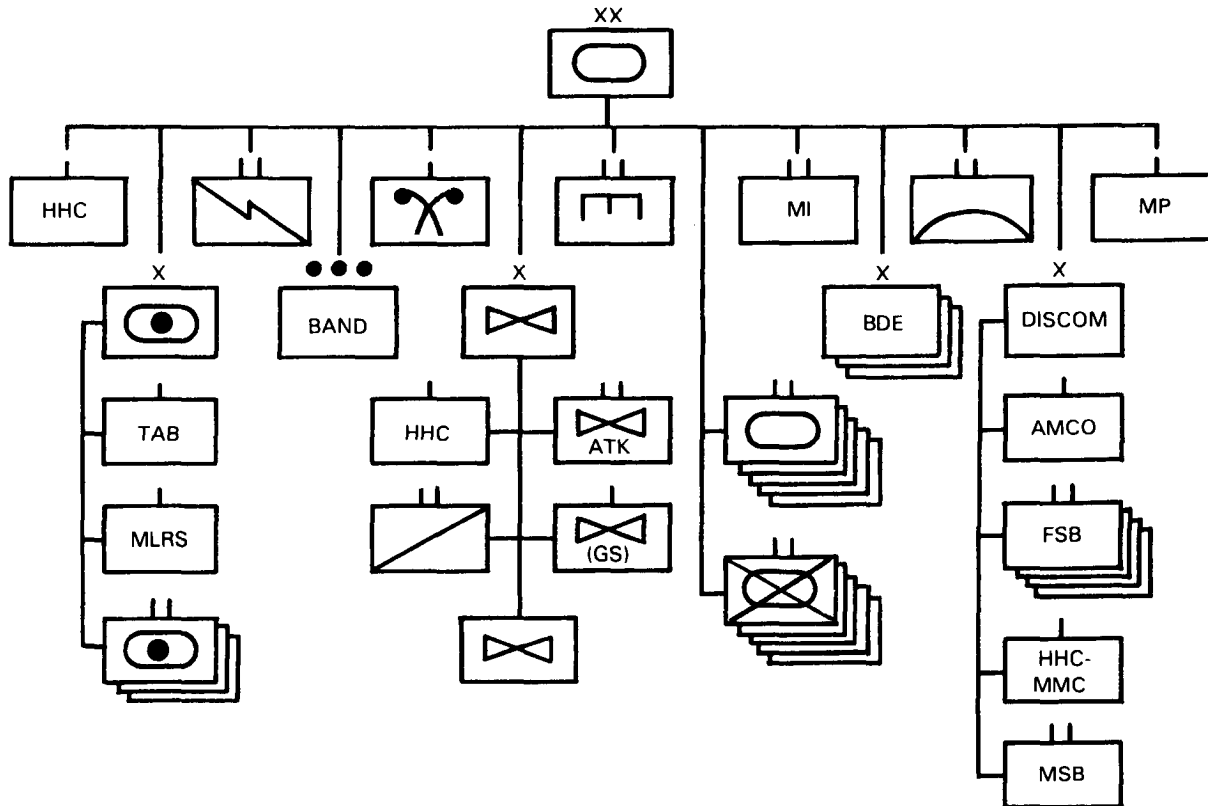

Figure 1-1. Heavy division.

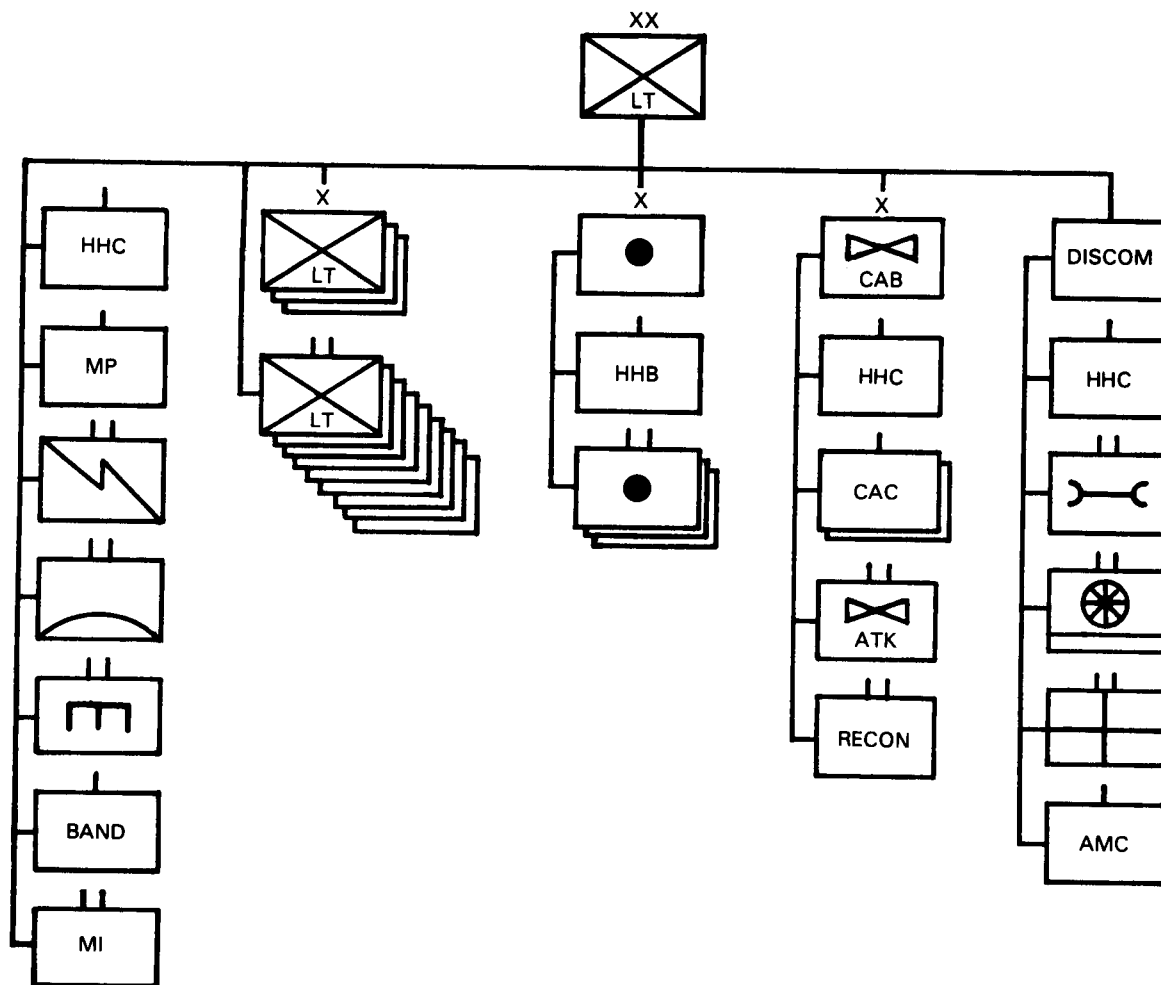

Figure 1-2. Light infantry division.

1-6. Airborne Division

a. The airborne division (Figure 1-3) is organized to be rapidly deployed anywhere in the world—

- To conduct combined arms combat parachute assault to seize and secure vital objectives behind enemy lines until linking up with other supporting forces.

- To exploit the effects of nuclear or chemical weapons.

- To rescue US nationals besieged overseas.

- To reinforce forward-deployed forces (if augmented with transportation).

- To serve as a strategic or theater reserve.

- To conduct large-scale tactical raids.

- To occupy areas or reinforce friendly or allied units beyond the immediate reach of ground forces.

- To capture one or more intermediate staging bases or forward operating bases for ground and air operations.

b. The airborne division conducts airborne assaults in the enemy's rear to secure terrain or to interdict routes of resupply or enemy withdrawal. It is ideally suited to seize, secure, and repair airfields to provide a forward operating base for follow-on air-landed forces. It can conduct air assault operations as well as other missions normally assigned to infantry divisions.

c. The airborne division achieves surprise by its timely arrival on or near the battlefield. With its aircraft capabilities, the Air Force can deliver the airborne division into virtually any objective area under most weather conditions.

d. Because the airborne division is tailored for airdrop operations, it can be employed more rapidly than other US divisions. All equipment is air transportable and, except for aircraft, is airdroppable. All personnel are trained for airborne operations.

e. Special staff considerations must be given to attack by enemy armor or motorized formations. The division does not have sufficient armor protection to defeat heavier armored formations at close range. Antiarmor weapons in the division compensate, but do not completely offset this deficiency.

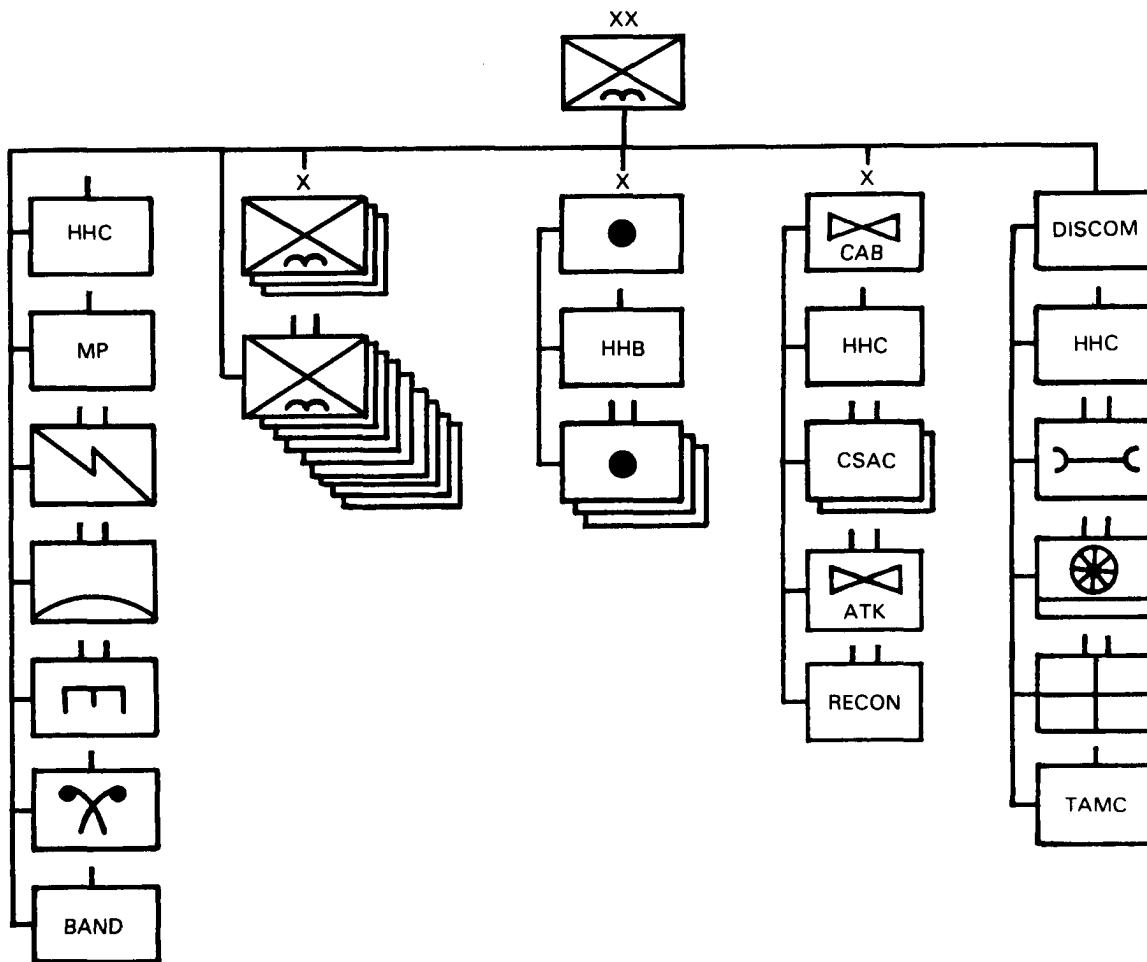

Figure 1-3. The airborne division.

1-7. Air Assault Division

a. The air assault division combines strategic and tactical mobility within its area of operations. The air assault division conducts combat operations over extended distances and terrain obstacles using infantry, aviation, CS, and CSS units (Figure 1-4).

b. Airmobile divisions provide the US Army the operational foundation, experience, and tactics for air assault division operations. However, the air assault division no longer merely conducts airmobile operations. It is important to recognize the distinction between airmobile and air assault. Airmobility is the use of Army aircraft to improve our ability to fight; such as moving troops and equipment from one secure area to another, then

helicopters departing the area of operation. Conversely, air assault operations involve combat, CS, and CSS elements (aircraft and troops) deliberately task organized for tactical operations. Aircraft are the prime movers and are integrated with ground forces. Additionally, air assault operations involve actions under hostile conditions, as opposed to air movement of troops to and from secure locations.

c. Once deployed on the ground, air assault infantry battalions fight like those of the infantry division; however, the task organization of organic aviation permits rapid aerial redeployment. The essence of air assault tactics is the rapid pace of operations over extended ranges. Execution of successive air assault operations enable the division commander to seize and maintain the tactical initiative.

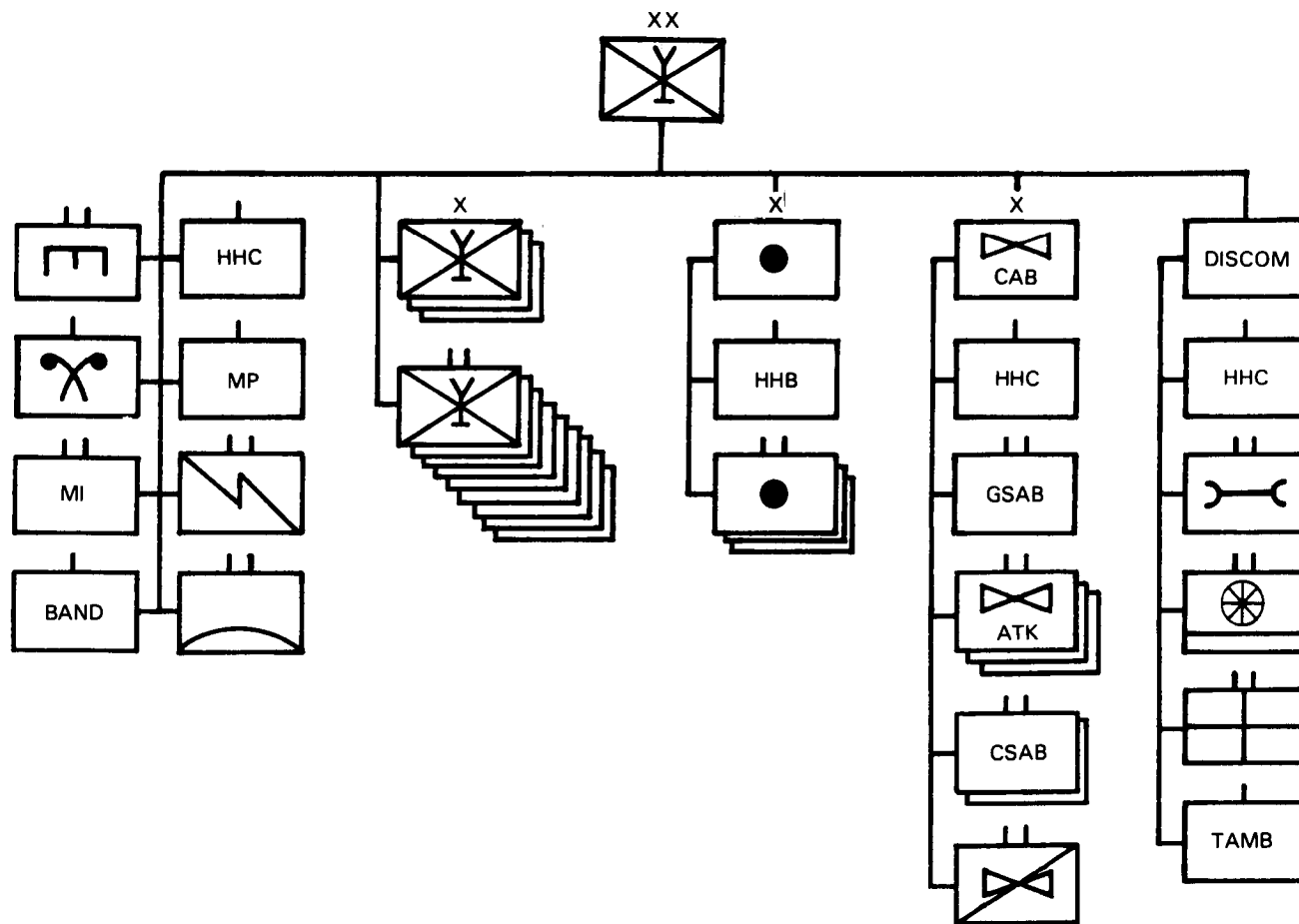

Figure 1-4. The air assault division.

Section III. THE DIVISION STAFF

1-8. The Division Commander

The division commander is responsible for everything the division does. He assigns missions, delegates authority, and provides guidance, resources, and support to accomplish the mission.

1-9. Assistant Division Commanders

Within a division there are two assistant division commanders (ADCs). The division commander prescribes their duties, responsibilities, and relationships with the staff and subordinate units. Normally the responsibilities are broken down as operations and training (or maneuver) and support. Thus, commonly a division will have an assistant division commander for operations and training

(ADC-OT) (or maneuver, ADC-M) and an assistant division commander for support (ADC-S).

1-10. Chief of Staff

The chief of staff directs the efforts of both the coordinating and special staffs. His authority usually amounts to command of the staff.

1-11. Staff Sections

The command sergeant major, G1, G2, G3, and G4 function at division level in much the same way their counterpart staffs function at battalion and brigade level (Figures 1-5 and 1-6). The G5 is the civil-military operations officer. This position is normally authorized only at division level and higher. For a detailed discussion of staff organization and functions, see FM 101-5.

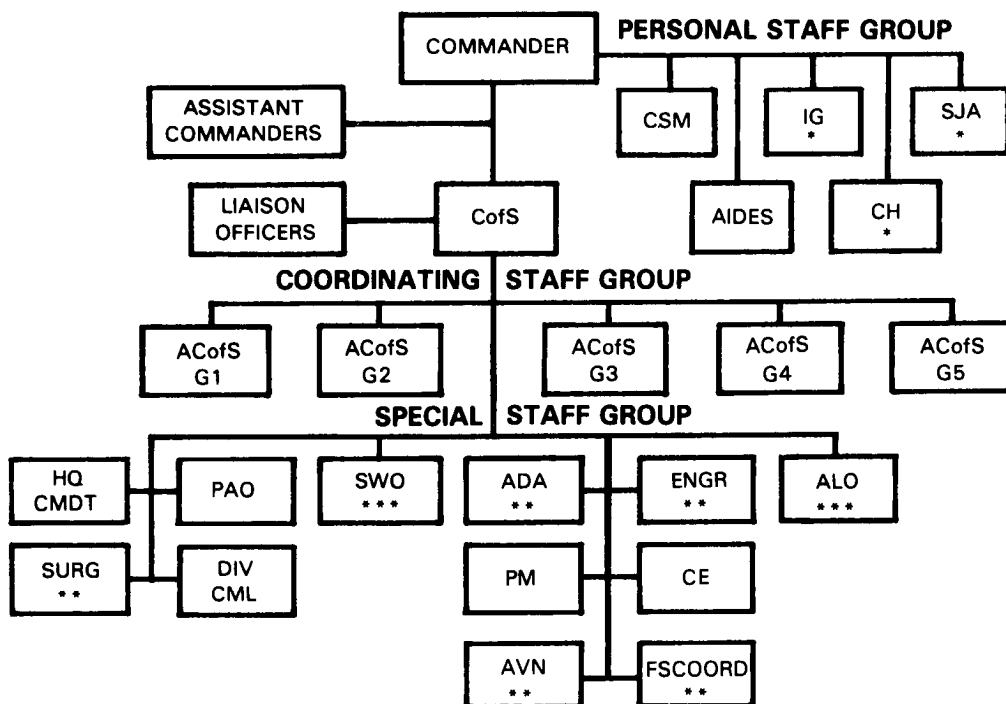

- * DIRECT ACCESS TO THE COMMANDER AS A PERSONAL STAFF OFFICER AS REQUIRED. THE IG AND THE SJA, BY REGULATION (AR 20-1 AND AR 27-1), WILL BE MEMBERS OF THE PERSONAL STAFF GROUP.
- ** ALSO SUBORDINATE UNIT COMMANDER.
- *** PROVIDED BY US AIR FORCE.

Figure 1-5. Light infantry division staff.

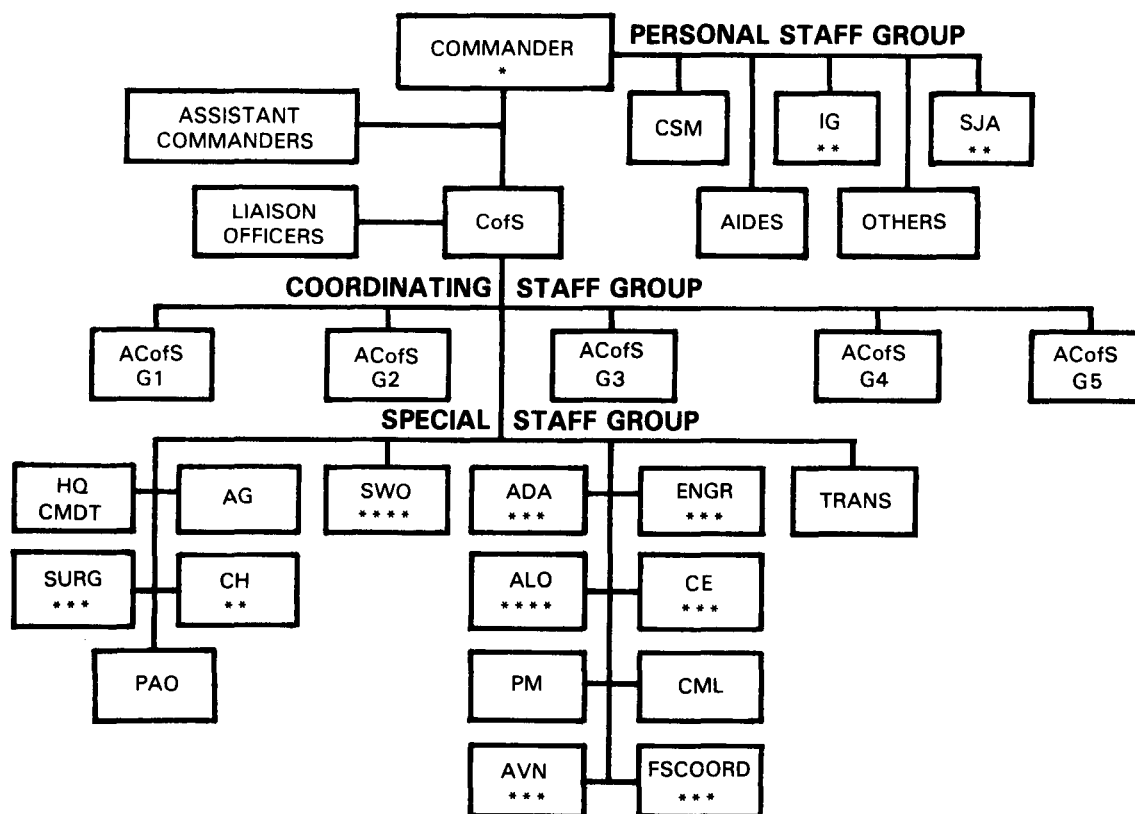

- * SPECIAL STAFF SECTIONS HAVE BEEN GROUPED UNDER THE COORDINATING STAFF SECTION RESPONSIBLE FOR PRIMARY STAFF COORDINATION.
- ** DIRECT ACCESS TO THE COMMANDER AS A PERSONAL STAFF OFFICER AS REQUIRED. THE IG AND THE SJA, BY REGULATION (AR 20-1 AND AR 27-1), WILL BE MEMBERS OF THE PERSONAL STAFF GROUP.
- *** ALSO SUBORDINATE UNIT COMMANDER.
- **** PROVIDED BY AIR FORCE.

Figure 1-6. Typical heavy division staff.

Section IV. THE BRIGADE

1-12. Organization of the Armored or Mechanized Infantry Brigade

The armored or mechanized infantry brigade is a combination of armored and mechanized battalion task forces (TFs) and other supporting units grouped under the command of a brigade headquarters. It participates in division or corps operations according to the principles and concepts set forth in FM 100-5 and FM 71-100.

a. Divisional Brigades.

(1) Close combat-heavy brigades are the major subordinate maneuver commands of armored and mechanized infantry divisions. The only permanent unit assigned to a brigade is its headquarters and headquarters company (HHC). The HHC provides direction and control over units assigned to, attached to, or supporting the brigade.

(2) Divisional infantry, armored, and mechanized battalions are attached to brigades: to destroy the enemy; and to seize and hold terrain. Normally, each brigade can control three or four maneuver battalions with their CS and CSS units. *When it is necessary to concentrate forces, control of more battalions may be necessary.* However, the battalions assigned to a brigade must be limited to a number that can be controlled in a very complex battle situation.

(3) With the addition of light infantry divisions to the force structure, the division commander may attach light infantry battalions to the heavy brigade for specific missions and for a short duration. Use of light forces requires careful consideration of key employment and logistics support.

(4) While the divisional brigade has no fixed slice of CS and CSS assets, it usually operates with a proportional share of the division's assets. Combined arms operations are conducted whenever appropriate. Normally, brigade support is provided by: a direct support (DS) field artillery (FA) battalion; an air defense artillery (ADA) battery; an engineer company; a forward area signal platoon; a military police (MP) platoon; combat intelligence and electronic warfare (IEW) elements; a tactical air control party (TACP); and a division support command (DISCOM) forward support battalion (FSB). Attack helicopter units may also operate with the brigade. When sorties are allocated for planning, United States Air Force (USAF) tactical air operations support the brigade.

b. Separate Brigades.

(1) Since separate brigades conduct operations under corps command, they are organized to provide their own support. Units organic to the separate brigade include—

- A brigade HHC to provide command and control (C²) and limited CS assets to include MP, chemical, and air defense (AD) elements.

- Tank and mechanized battalions to fight battles, destroy or disrupt enemy forces, and seize and hold terrain.

- An armored cavalry troop for reconnaissance, security, and economy-of-force operations.

- A direct support FA battalion to provide fire support.

- An engineer company for combat engineer support.

- A military intelligence (MI) company to assist in collecting, processing, and disseminating intelligence, and to support EW operations.

- A support battalion organized to provide CSS in the same way as the DISCOM's FSB provides CSS to divisional brigades; but with the added ability to link directly with corps support command (COSCOM) for augmentation.

(2) Additional combat, CS, and CSS units may be attached to a separate brigade as required by the brigade's mission and operating circumstances. The separate brigade may be attached to a division (less support) but is usually controlled by a corps.

1-13. Organisation of Infantry Brigades

a. Divisional Brigades.

(1) Infantry, airborne, or air assault brigades are the major subordinate maneuver commands of infantry, airborne, or air assault divisions.

(2) Normally, there are three or four brigades assigned to an infantry division, depending on operational requirements; however, most often there are three.

(3) Combat support and CSS are provided to the *brigade* by the *division*. Normally, field artillery support is provided by a light field artillery DS battalion. An engineer company, a forward area signal center platoon, combat electronic warfare and intelligence elements, and division support command forward support elements also routinely support a brigade. From time to time, attack helicopter units and USAF bombers may operate in support of the brigade.

b. Separate Brigades.

(1) Since separate brigades sometimes conduct independent operations, they are organized to provide their own support. Each is generally organized with—

- A brigade HHC to provide command and control.
- Infantry battalions to destroy the enemy and to seize and hold terrain.
- A support battalion with several support units to provide CSS.
- A combat electronic warfare and intelligence company to assist in collecting,

processing, and disseminating intelligence, and to support electronic warfare operations.

- A light field artillery battalion to provide fire support.
- An engineer company for combat engineer support.
- An armored cavalry troop for reconnaissance, security, and economy of force operations.

(2) Additional combat, CS, and CSS units may be attached to the separate brigade as required. The separate brigade may be attached to a division or placed under the control of a higher command such as a corps.

Section V. THE BATTALION

1-14. Organization of the Infantry Battalion

a. Organization. An infantry battalion is organized and equipped to give it the capabilities needed to accomplish its missions. It is large enough to engage enemy regiments using a full range of organic and nonorganic weapons and support. Also it is small enough that the battalion commander can personally lead and immediately influence the action of his units in battle.

(1) To understand the organizational structure of the battalion, one must understand the organization roles of echelons above and below the battalion and how the battalion serves as the interface for these echelons.

(2) Within the context of organizational roles, platoons normally fight as part of a company. Companies fight using their subordinate platoons as fire or maneuver elements. Battalions provide support to the companies; ensure the battlefield has depth and synchronize the various arms and services to achieve the maximum effect from the available forces. The brigade task-organizes the battalion, fitting the forces to the ground, mission, and enemy situation. Divisions provide CS and CSS

force multipliers. Corps conducts operational level warfare, providing additional CS and CSS assets in accordance with the corps main effort.

(3) To execute AirLand Battle doctrine, the infantry battalions require: adequate troop strength; an organic antiarmor capability; supporting arms; optimized task organization based upon the mission; and adequate support. These requirements are met through the organization of the infantry battalions and through augmentation and task organization where required.

b. Types of Battalions. There are six basic types of nonmechanized/nonmotorized infantry battalions: infantry, air assault, airborne, ranger, light, and mountain (Figures 1-7, 1-8, and 1-9). The fundamental combat mission of the infantry battalion, regardless of type, is to destroy or capture the enemy by fire and maneuver. To accomplish specific missions, the battalion is normally augmented with combat, CS, and CSS assets.

c. Task Organization. Normally, infantry battalions operate as table of organization and equipment (TOE) units only in garrison. For training and for combat, they are task organized for

the mission at hand. Task organizing tailors the unit to get the most from its capabilities and to minimize its limitations. It is a temporary grouping of forces designed to accomplish a particular mission. Task organization involves the distribution of available assets to subordinate control headquarters by attaching or placing assets under operational

control (OPCON) to the subordinate. Task organization is made after analyzing the considerations of METT-T. When developing the task organization, the commander must clearly understand the capabilities and limitations of his organic and supporting units; he must consider the existing command and control relationships.

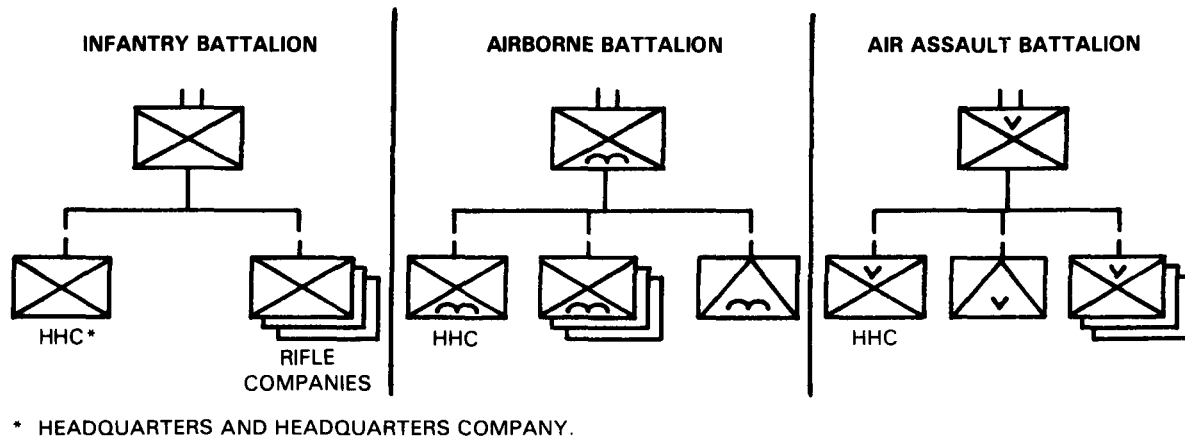

Figure 1-7. Infantry, airborne, and air assault battalions.

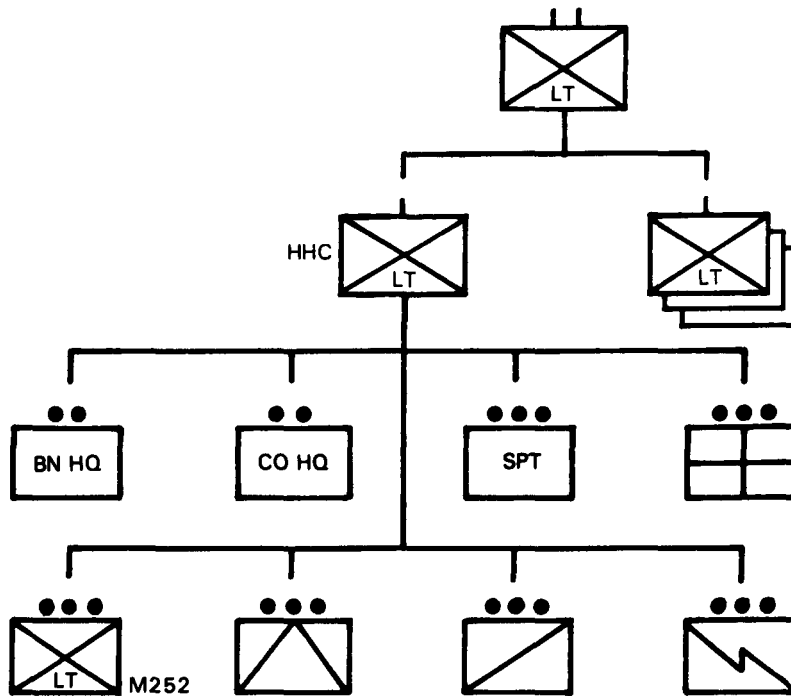

Figure 1-8. Light infantry battalion.

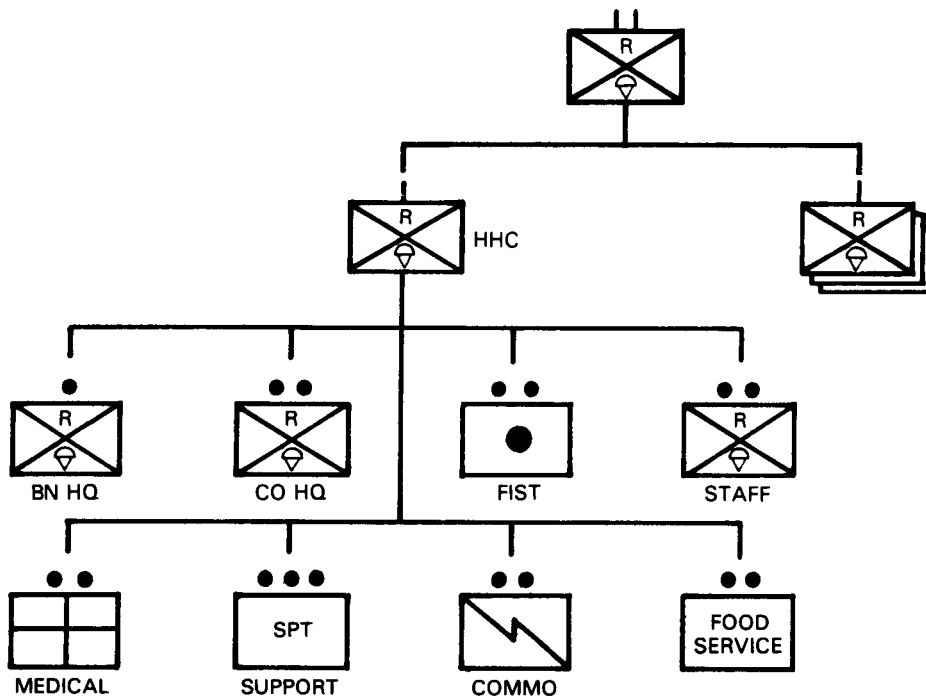

Figure 1-9. The ranger battalion.

1-15. Organization of the Mechanized Infantry and Armor Battalions

Mechanized infantry battalions and armored battalions are organized, equipped, and trained to accomplish specific missions; each type battalion has unique capabilities and limitations (Figure 1-10 and 1-11).

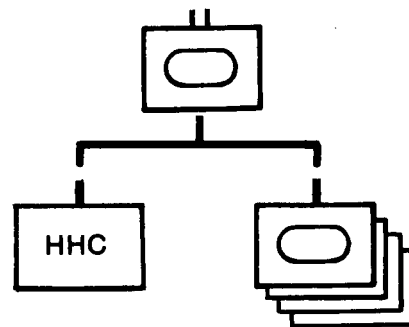

Figure 1-11. Armored battalion.

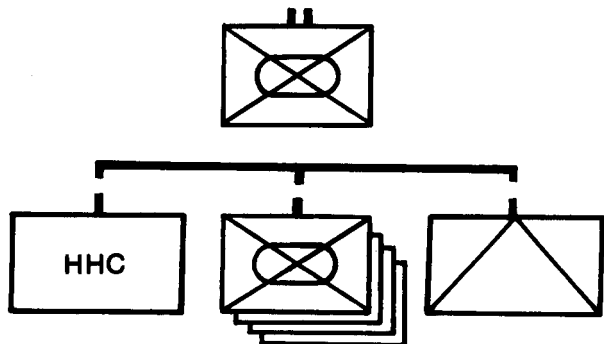

Figure 1-10. Mechanized infantry battalion.

a. Mission.

(1) The missions of mechanized infantry and armored battalions in their pure configuration are—

(a) The mission of the mechanized infantry battalion is to: destroy or capture the enemy by means of fire and maneuver; or repel his assault by fire, close combat, and counterattack.

(b) The mission of the armored battalion is to close with and destroy enemy forces using fire, maneuver, and shock effect; or repel his assault by fire and counterattack.

(2) Battalion TFs accomplish missions and tasks as part of a brigade's operation. Occasionally, TFs will conduct operations directly under a division's or an armored cavalry regiment's control; such as, participating in the higher headquarters covering force; acting as a reserve; or forming a tactical combat force in rear area operations.

b. Capabilities.

(1) The capability of the armored and mechanized infantry battalions is increased through task organization. Based on situational estimates, the brigade commander task-organizes armored and mechanized infantry battalions by cross-attaching companies between these units. As a rule, cross-attachment is done at battalion, because it has the necessary command, control, and support capabilities to employ combined arms formations. The brigade commander determines the mix of companies in a TF. Similarly, the TF commander may cross-attach platoons to form company teams for specific missions.

(2) Tank and mechanized infantry battalion TFs apply their mobility, fire power, and shock effect to—

- Conduct sustained combat operations in all environments.
- Accomplish rapid movement and limited penetrations.
- Exploit success and pursue a defeated enemy as part of a larger formation.
- Conduct security operations (advance, flank, or rear guard) for a larger force.
- Conduct defensive, retrograde, or other operations over assigned areas.

- Conduct offensive operations.

c. Limitations.

(1) Because of the high density of tracked vehicles, the battalion has the following limitations:

- Mobility and fire power are restricted by urban areas, dense jungles and forests, very steep and rugged terrain, and significant water obstacles.
- Strategic mobility is limited by substantial quantities of heavy equipment.
- Consumption of supply items is high, especially Classes III, V, and IX.

(2) Battalions are task-organized according to mission; they are routinely augmented to improve engineer, fire support, air defense, intelligence, and CSS capabilities.

1-16. Battalion Task Force on the AirLand Battlefield

a. The foundation of AirLand Battle doctrine at the TF level is classical maneuver warfare. In its simplest form, maneuver warfare involves using a part of the force to find, then fix or contain the enemy, while the remainder of the force attacks his weakest point—usually a flank or the rear. The goal is to mass enough combat power at the critical place and time to destroy or threaten the enemy with destruction, while preserving freedom for future action.

b. The TF commander must understand the intent of the brigade and division commander to properly employ his force. The TF commander develops his intent and concept and accepts risks to achieve decisive results. He seizes the initiative early and conducts offensive action aimed at imposing his will on the enemy. The objective of his maneuver is to position strength against weakness, throw the enemy off balance, and aggressively follow-up to defeat and destroy the enemy.

Section VI. THE BATTALION STAFF

1-17. Command and Control Responsibilities of the Battalion

The commander establishes a standard command and control system by defining the functions of key individuals, organizations, and facilities. He organizes his staff in a manner to accomplish the mission. He will develop a basic organization flexible enough to be modified to meet changing situations. This section discusses the individual and staff functions and responsibilities and how they are organized to facilitate command and control.

1-18. Staff

a. Commander. The commander commands and controls subordinate combat, CS, and CSS elements that are organic or attached to his unit or under its OPCON. The commander's main concerns are to accomplish his unit's mission and to ensure the welfare of his soldiers.

(1) The commander cannot win the battle alone. He must rely on his staff and subordinate commanders for advice and assistance in planning and supervising operations. He must completely understand their limits and capabilities. He must train subordinate commanders to execute his concept in his absence. Also, he must cross-train his staff to continue unit operation when staff elements suffer combat losses.

(2) The staff reduces the demands on the commander's time; they assist him by—

- Providing information.
- Making estimates and recommendations.
- Preparing plans and orders.
- Supervising the execution of orders issued by, or in the name of, the commander.

The commander assigns clear-cut responsibility for functions to unit staff officers to ensure that conflicts do not arise. As a rule, staff officers are

delegated the authority to say "yes" to requests by subordinate unit commanders. They defer to command prerogatives when the answer is "no." The staff must be responsive to subordinate unit commanders.

b. Executive Officer. The executive officer (XO) is second in command and the principal assistant to the battalion commander. The XO is prepared to assume the duties of the commander. He formulates and announces staff operating policies and ensures the commander and staff are informed on matters affecting the command. He ensures that —

- Required liaison is established.
- All staff officers, unless otherwise instructed by the commander, inform him of any recommendations or information they gave directly to the commander; or any instructions they receive directly from the commander.

He represents the commander, when required, and exercises supervision of the tactical operations center (TOC) and its operations.

c. Command Sergeant Major. The command sergeant major (CSM) is the senior NCO in the unit. He acts in the name of the commander when dealing with other NCOs in the unit; he is the commander's primary advisor concerning the enlisted ranks. He is not an administrator, but must understand the administrative, logistical, and operational functions of the unit to which he is assigned. Since he is normally the most experienced soldier in the unit, his attention should be focused on operations, training, and how well the commander's decisions and policies are being carried out. He is the senior enlisted trainer in the organization. He coaches and trains first sergeants and platoon sergeants; he works very closely with company commanders in this regard. He maintains close contact with subordinate and attached unit NCOs. The CSM may act as the commander's representative in supervising critical aspects of an operation. For example, he may help control movement through a breach in an obstacle; at a river crossing, or may assist in passage of lines. The CSM normally leads the advance/quartering party during a major

movement. He may also help in the CSS effort during the battle.

1-19. Coordinating Staff

a. S1 (Adjutant).

(1) The S1 has primary responsibility for all personnel matters. This responsibility includes maintenance of unit strength and personnel service support. He is responsible for replacement policies and requirements; unit strength and loss estimating; morale support; and battalion administration. The S1 exercises staff supervision of medical, legal, religious, safety, and civil affairs (including civilian labor) assets. Additionally, he monitors postal services and public affairs. The S1 is responsible for administrative support for enemy prisoners of war, civilian internees, and staff supervision of casualty evacuation.

(2) The S1 operates from the field trains with the S4. He shares supervisory responsibility for logistics operations with the S4. The S1 and S4 must cross-train to be able to conduct continuous operations. The term "operate" does not mean that the S1 stays at one location at all times; he will move around as necessary to accomplish his mission.

b. S2 (Intelligence Officer). The S2 exercises overall staff responsibility for intelligence. He prepares the intelligence preparation of the battlefield (IPB) with the commander and S3 using—

- Higher collection sources.
- Ground and aerial reconnaissance.
- Observation posts.
- Ground surveillance radar.
- Target acquisition.
- Electronic warfare assets.

In conjunction with the IPB process, he prepares and disseminates intelligence estimates.

c. S3 (Operations and Training Officer). The S3, as the operations officer, is the commander's principal assistant for coordinating and planning the battle. The S3—

- Monitors the battle.
- Makes sure that CS assets are provided when and where required.
- Anticipates developing situations.

He advises the commander on—

- Combat and CS matters.
- Organization and training.
- Operational matters during the battle.

He prepares the operations estimate and conducts planning and coordination with other staff sections resulting in published operation orders, operations plans, and training programs. In conjunction with his planning duties, he is responsible for psychological operations (PSYOP); electronic warfare (EW) activities, operations security (OPSEC); deception; and (in conjunction with the S4) tactical troop movement. He establishes priorities for communications to support tactical operations and coordinates with XO and battalion signal officer on the location of the main command post (CP).

d. S4 (Logistics Officer). The S4 has primary staff responsibility for determining CSS requirements and priorities. His section is responsible for the procurement, receipt, storage, and distribution of supplies; for transportation of units, personnel, and CSS items to their required locations. He designates lines of movement and locations of CSS elements; prepares and develops CSS plans in concert with the current tactical plan. The S4 is responsible for the preparation, authentication, and distribution of CSS support plans and orders when published separately. The S4 establishes the requirements for civilian labor and the collection and disposal of excess property, salvage, and captured material.

e. Battalion Maintenance Officer. The battalion maintenance officer (BMO) plans, coordinates, and supervises the maintenance and recovery efforts of the maintenance platoon and ensures that adequate maintenance support is provided to the TF. Although a staff officer in the battalion headquarters, he is also the maintenance platoon leader. The maintenance warrant officer assists the BMO by providing technical assistance and supervision of the maintenance platoon. The BMO supervises the unit maintenance collection point (UMCP) in the armored and mechanized infantry battalions only.

1-20. Special Staff

a. S3 Air. The S3 air, the principal assistant to the S3, is normally in the TOC. He assumes the duties of the S3 in his absence. He coordinates the employment of close air support (CAS) with the fire support element (FSE) and the TACP, as well as the air defense section leader.

b. Nuclear, Biological, and Chemical Personnel. The assistant S3/chemical officer is assigned to the S3 section of combat battalions with a chemical NCO as his assistant. A decontamination specialist is assigned to the HHC of airborne and air assault battalions. The chemical officer and NCO train and supervise the battalion decontamination crew. During combat operations, chemical personnel provide a 24-hour capability within the S3 section to receive, correlate, and disseminate information on nuclear, biological, and chemical (NBC) attacks. They consolidate subordinate units' operational exposure guide (OEG) radiation status and report to higher headquarters as required. They provide recommendations concerning mission-oriented protection posture (MOPP) levels and employment of supporting NBC reconnaissance and smoke units. If the unit comes under NBC attack, battalion NBC personnel organize and establish a battalion NBC center, supervise activities of radiological survey and monitoring teams; chemical detection teams; and coordinate and supervise decontamination missions conducted with or without support level decontamination assets.

c. Tactical Intelligence Officer. The tactical intelligence officer works under the supervision of the S2; he is part of the two-man battalion information coordination center (BICC). The BICC'S

primary responsibility is to manage the unit intelligence collecting, processing, and disseminating effort for the S2. The BICC develops and initiates the reconnaissance and surveillance (R&S) plan; identifies requirements that cannot be met by the battalion's assets; and notifies the brigade S2.

d. Battalion Communications-Electronics Staff Officer. The battalion communications-electronics staff officer (CESO) advises the commander and staff officers on all communications-electronics matters. He plans, manages, and directs all aspects of the unit communications systems. The CESO exercises staff supervision over the communications activities of subordinate and attached units; he plans and supervises the integration of the unit communications system into the communications systems of higher, lower, and adjacent headquarters.

e. Surgeon. The surgeon advises and assists the commander on matters concerning conservation of the fighting strength of the command to include preventive, curative, retroactive care, and related services. The surgeon (medical platoon leader), with the aid of the physicians' assistant, operates the battalion aid station (BAS) at the combat trains. He and medical assistants provide training for the medical platoon; treatment for the wounded and sick; and information on the health of the battalion to the commander. A Medical Service Corps officer, field medical assistant, assisted by the platoon sergeant, handles the administration and logistics of the medical platoon. Refer to Appendix A for training procedures.

f. Chaplain. The chaplain is normally a member of the commander's personal staff and has direct access to the commander. The chaplain exercises the necessary staff authority for developing, coordinating, and executing the Religious Support Plan. The chaplain advises the commander and staff on matters of religion, morals, and morale, and on the influence of indigenous religious groups and customs on the commander's courses of action. Additionally, the chaplain facilitates soldiers' free exercise of their religious rights, beliefs, and worship practices, and makes recommendations for ethical decision-making and moral leadership programs (FM 16-1).

1-21. Other Staff Assets

a. Headquarters and Headquarters Company Commander. The HHC commander has the responsibility of ensuring that the command facilities are provided logistical support (Figure 1-12). Normally, he places his XO with the main CP to supervise support, security, and movement. He locates himself at the field trains to monitor and coordinate all battalion activities there. He uses land lines and messengers to control all elements in

the field trains and communicates with the combat trains using the administration/logistics net (a frequency modulation (FM) radio net). The HHC commander is available for other tactical missions as dictated by the estimate of the situation. These roles normally come into play during operations other than sustained ground combat. They may include coordination and control of the reconnaissance/counter-reconnaissance effort; combat patrols; or any other task designated by the battalion commander.

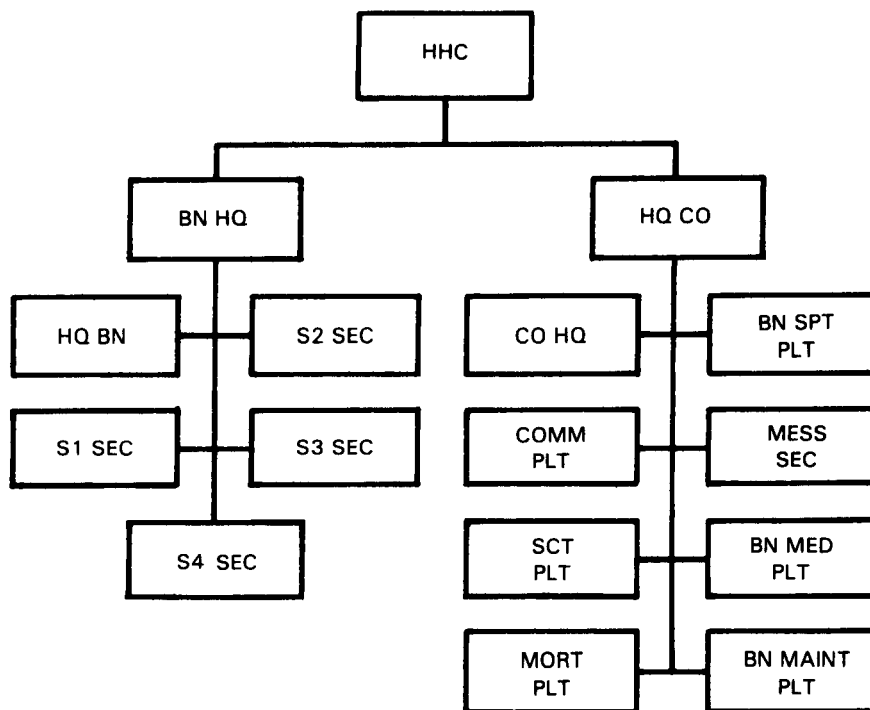

Figure 1-12. Headquarters and headquarters company, infantry battalion (mechanized).

b. Fire Support Officer. The integration of fire support into the maneuver operation is a decisive factor in the success of battle. The maneuver commander is responsible for the whole of his operation including the fire support plan. The fire support officer (FSO) is responsible for advising the commander on the best available fire support resources; for developing the fire support plan; for issuing the necessary orders in the name of the commander and for implementing the approved fire support plan. The FSO normally locates with the commander, but it may be necessary to locate where he can communicate best.

c. Air Defense Artillery Officer. The senior leader of any supporting ADA unit(s) advises the commander on employment of ADA assets. During the planning process, he is at the main CP to ensure the integration of air defense into the concept of operation. During the execution of the plan, he positions himself to best command and control the air defense assets. He monitors the command net to remain responsive to the needs of the commander. He also monitors the early warning net to assist in the acquisition and dissemination of early warning information as a member of the Army airspace command and control system.

d. Engineers. The leader of the supporting engineer unit advises the commander on employment of engineer assets. During the initial planning, he is at the TOC to advise the commander on employment of his unit. During the battle, the engineer unit provides a representative with a radio at the TOC, if possible, to coordinate the engineer effort. If no representative is available, the TOC periodically monitors the engineer net. Regardless of the system used, the engineer leader is responsible for maintaining constant communications with the battalion.

e. Antiarmor Company Commander/Platoon Leader (Light Battalion). This leader advises the commander on the tactical employment

of his weapon systems. He may serve as a fourth maneuver element or as an alternate battalion CP when properly task-organized.

f. Scout Platoon Leader. He advises the commander and the S2 on the employment of his element. He is responsible for conducting tactical reconnaissance in support of the battalion.

g. Battalion Mortar Platoon Leader. He advises the battalion commander and the FSO on tactical employment of the battalion mortar platoon; he may assist the FSO with his fire support coordinator (FSCOORD) responsibilities. His platoon headquarters may also serve as an alternate CP.

Section VII. THE DIVISIONAL ARMORED CAVALRY SQUADRON

1-22. Mission

The squadron is employed under divisional control. The squadron or any of its troops may be temporarily attached to or placed under the control of a brigade, although this should not be routine. The squadron will locate itself based on its mission and whom it is supporting. Subordinate elements of the squadron are organized for combat and used as dictated by the factors of METT-T. At squadron level, this occasionally involves cross-attachment of platoons between cavalry troops and augmentation with armored or mechanized infantry companies. Normally troops operate as organized.

1-23. Divisional Armored Cavalry Squadron

a. Organization. An armored cavalry squadron assigned to an armored or mechanized infantry division contains a headquarters and headquarters troop (HHT), two armored cavalry troops, and two air cavalry troops (Figure 1-13).

b. Organization for Combat. The squadron may be used as organized or reinforced, as is the

regimental armored cavalry squadron. The squadron is normally under division-d control. The squadron or one of its troops may be temporarily attached to or placed under OPCON of a brigade. Subordinate elements of the squadron are organized for combat and used in the same way as subordinate elements of the regimental armored cavalry squadron. Squadron command and control parallels that of the regiment, differing only in scope of operations and level of command.

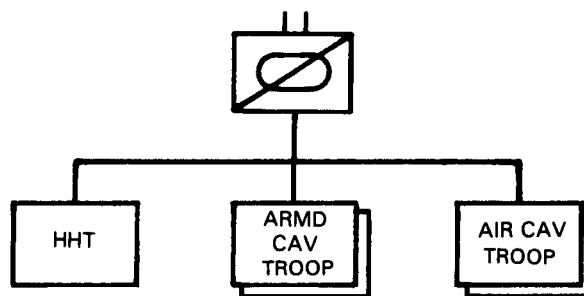

Figure 1-13. Armored cavalry squadron (heavy division) (H).

CHAPTER 2

THE ARMORED CAVALRY

Section I. ARMORED CAVALRY REGIMENT

2-1. Organization

The armored cavalry regiment (ACR) is used by the corps commander as a reconnaissance and security force; it is strong enough to engage in decisive combat to help achieve his overall goal of destroying the enemy's cohesion and will to fight. The ACR is the self-contained force around which the covering force is built. Further, it provides an economy-of-force structure for use in the main battle area (MBA) for offensive and defensive operations.

2-2. Organization for Combat-Armored Cavalry Regiment

The ACR provides the economy-of-force structure upon which to build the covering force organization (Figure 2-1). The ACR is augmented by other corps and division assets as required. Assets well-suited to reinforce the ACR are ADA, FA, engineers, attack helicopters, and tactical aircraft. The covering force makes maximum use of these assets because of their range; their ability to be applied quickly to relieve stress; and their ability to apply additional pressure as the battlefield situation

dictates. Armor-heavy maneuver battalions from the division may also augment the covering force; however, the combat power available for the MBA must not be diluted.

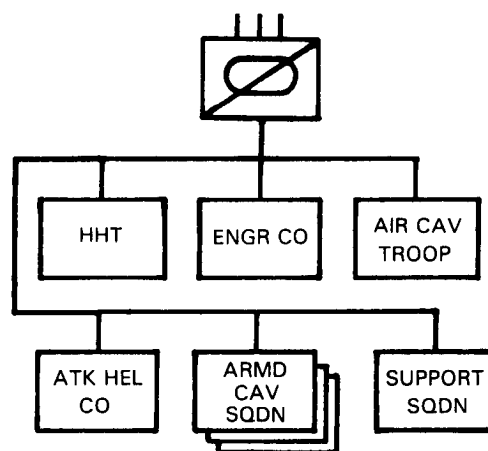

Figure 2-1. Armored cavalry regiment.

Section II. REGIMENTAL ARMORED CAVALRY SQUADRON

2-3. Organization-Regimental Armored Cavalry Squadron

The **regimental** armored cavalry squadron contains a HHT, three armored cavalry troops, an armored company, and a self-propelled 155-mm howitzer battery (Figure 2-2). The squadron usually functions as part of its parent regiment, but may operate separately.

2-4. Organization for Combat

a. The regimental squadron may be reinforced with maneuver, CS, and CSS units as is the regiment. It is usually reinforced by units one organizational size lower than provided a regiment. Whereas the regiment is reinforced with one or more maneuver battalions or TFs, a squadron normally receives a company or team.

b. The squadron usually functions as part of its parent regiment, but may be attached to another regiment, a brigade, or higher headquarters. The squadron's mission and location in relation to its parent regiment are the determining factors. It may be used as organized or it may be reinforced.

c. The squadron can conduct reconnaissance missions; security missions; offensive or defensive missions as an economy force. It can attack autonomously, or can supplement the attack of other maneuver forces. Its mobility and firepower suit it for exploitation and pursuit missions. In the defense the cavalry, with its combined arms organization through troop level, is well-suited as an economy-of-force element to delay over extended frontages; to defend secondary avenues of approach; or to fight beside divisional

units from battle positions (BP) as part of the regiment. Its organic systems provide long-range antiarmor engagement capability. Its tactical mobility facilitates rapid lateral or in-depth

movement on multiple routes. Further, these capabilities make the cavalry a potent counterattack force.

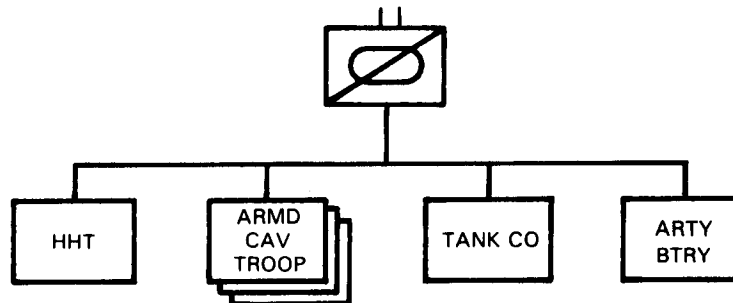

Figure 2-2. Regimental cavalry squadron.

Section III. ARMORED CAVALRY REGIMENT MEDICAL COMPANY DIVISION-LEVEL HEALTH SERVICE SUPPORT

2-5. Mission

The mission of the ACR medical company is to provide division-level health service support (HSS) within the ACR. This HSS includes medical staff advice and assistance, and unit-level HSS on an area basis to all assigned and attached elements operating in the regiment area (Figure 2-3).

2-6. Capabilities

This unit provides—

a. Command and control of attached medical elements, to include medical planning medical policies; support operations, as well as coordinating movement of patients within and out of the regiment area.

b. Advice to the regiment commander and support squadron commander on the health of the command and medical matters affecting the regiment.

c. Coordination for corps-level medical support operations within the regiment.

d. Development, preparation, and coordination of the medical portion of the regiment plans and policies.

e. Allocations of medical resources (personnel and equipment) to all assigned and attached units of the regiment.

f. Triage, initial resuscitation/stabilization, and preparation for further evacuation of sick, wounded, battle fatigued, or injured patients generated in the regiment rear area.

g. Ground evacuation for patients from Echelon I (unit-level) treatment squads to Echelon II (regiment/division-level) medical treatment facilities (MTFs).

h. Treatment squads, for limited periods of time, to provide support to forces involved in rear battle combat operations or performing reconstitution/reinforcement operations as appropriate. Regiment (division)-level HSS will be reduced during periods when the treatment squad(s) is used to reconstitute/reinforce appropriate units.

i. Division-level medical supply, medical equipment maintenance repair parts, and medical equipment maintenance support to regiment and attached units on an area basis. The regiment medical supply section (RMSS) maintains a 5-day stock of emergency PUSH packages and individual medical items. Normal resupply of medical units (for example, medical platoons/sections) will occur every

five days with PUSH packages until the corps medical supply, optical and maintenance unit (MEDSOM) or medical logistics (MEDLOG) battalion is established.

j. Emergency dental care to include treatment of maxillofacial injuries, sustaining dental care designed to prevent or intercept potential dental emergencies, and limited preventive dentistry.

k. Laboratory and radiology services commensurate with the regiment (division)-level of medical treatment.

l. Patient holding for up to 40 patients awaiting evacuation or who will return to duty within 72 hours.

m. Outpatient consultation services for patients referred from unit level HSS facilities.

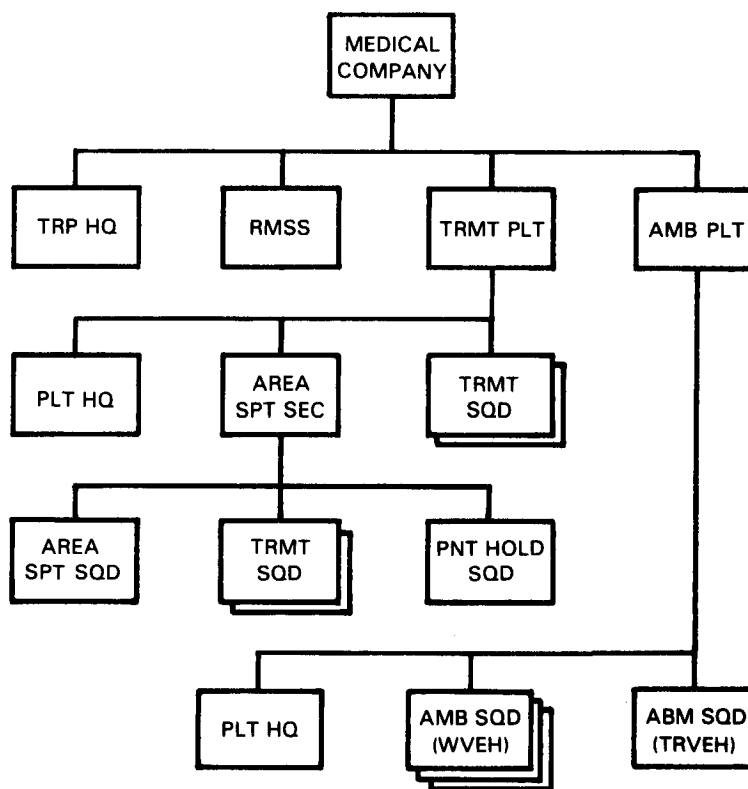

Figure 2-3. Medical company/support squadron, ACR.

Section IV. SQUADRON (UNIT) LEVEL HEALTH SERVICE SUPPORT ARMORED CAVALRY SQUADRON

2-7. Medical Platoon

a. The medical platoon sorts, treats, and evacuates the sick and wounded. It stocks medical supplies for the squadron and provides all Class VIII support. It also performs organizational maintenance and evacuation for all squadron medical equipment. The medical platoon is led by

the squadron surgeon. He is assisted by a Medical Service Corps lieutenant and a warrant officer (WO) physicians' assistant (PA). The squadron surgeon is supervised by the S1. He must understand the scheme of maneuver and the planned disposition of the units to support the operation. See Figure 2-4 for the organizational staffing of the squadron medical platoon.

b. Aidmen attached to troops give emergency medical treatment and ensure that patients who must be evacuated are prepared and promptly moved. While the troop can establish an aid post, it primarily sorts casualties and evacuates injured personnel.

c. An armored ambulance from the medical platoon evacuation section normally evacuates patients requiring further treatment to the squadron medical aid station.

2-8. Employment

a. The squadron aid station is located as far forward as possible, normally with the squadron combat trains. It should be in an area providing cover and concealment and near concealed helicopter landing areas. The squadron aid station is supervised by a physician and a PA. Here, triage is performed so that the most seriously wounded are cared for first.

b. The platoon has a M577 command post carrier, which serves as the aid station. Other platoon vehicles include two M35A2 cargo trucks, a M998 HMMWV, and eight M113 ambulances. The treatment squad may operate as two treatment teams; however, doing so requires one team to use the HMMWV. A common configuration places one treatment team with the M577 in the combat trains as the primary aid station. The other team operates near the forward area rearm and refuel point (FARRP).

c. The medical platoon leader of an armored cavalry squadron has perhaps the most difficult job a medical platoon leader can have. He must support a unit which is by nature faster, more autonomous, and more audacious than any divisional unit. To effectively meet this challenge requires initiative and flexibility. Prestablished medical support concepts which work for other units may not always be effective in a cavalry unit. What follows are a number of general guidelines. The key lies in tailoring these concepts and developing new ones. The goal is to develop the best system for each specific unit and each anticipated tactical situation.

- **Aid station/treatment squad.** Operate a primary aid station from the M577 in the

combat trains. The physician/platoon leader should be with this team. The PA and his team should operate near the FARRP using the HMMWV for transportation.

- **Aidman section.** The aidman section of a cavalry squadron consists of eleven combat medics. One medic locates in the troop trains moving with either the troop first sergeant or executive officer; two medics per troop; two in the armored company; and two in the howitzer battalion.

- **Ambulance section.** The medical operations officer assisted by the platoon sergeant manages evacuation operations. He may locate with the aid station, or forward with the maintenance collection point/patient collecting point (MCP/PCP). One ambulance is normally positioned with each troop, four at the MCP/PCP, and one with each treatment team. Alternate configurations include—

- Two ambulances with each troop, two at the MCP/PCP, and one with each treatment team, or

- Four ambulances at the MCP/PCP and two with each troop.

There are other configurations which may be used as dictated by the factors of METT-T. Remember, medical company ambulances should be positioned with the aid station. This fluctuating support arrangement makes thorough coordination absolutely essential. The medical platoon must know who will support it during each phase of an operation. Medical company ambulances positioned forward to support the squadron are essential (a cavalry squadron will likely need more ambulance support than would an armored or infantry battalion).

- **Other considerations.** Often, it must operate a considerable distance from the regiment's main body. The squadron frequently disperses over a broad frontage. The following considerations apply:

- The medical platoon must be prepared to handle mass casualty situations. Mass casualties may occur during very mobile, fast moving situations.

- Plans for the use of nonmedical vehicles (including aircraft) are essential (FM 8-10-8).

- The cavalry medical platoon may expend supplies rapidly. Resupply plans must be SOP. (See paragraph 3-8 for resupply procedures.) Use PUSH packages.

- The relationship between the platoon and the medical company must be clearly established.

- The combat lifesaver is essential to effective medical support. The combat lifesaver will be invaluable when the squadron operates distant from its regimental support units.

- Although always a last resort, procedures for abandoning patients must be established. The squadron commander makes this determination. If patients are abandoned, some medical personnel with supplies must remain with them.

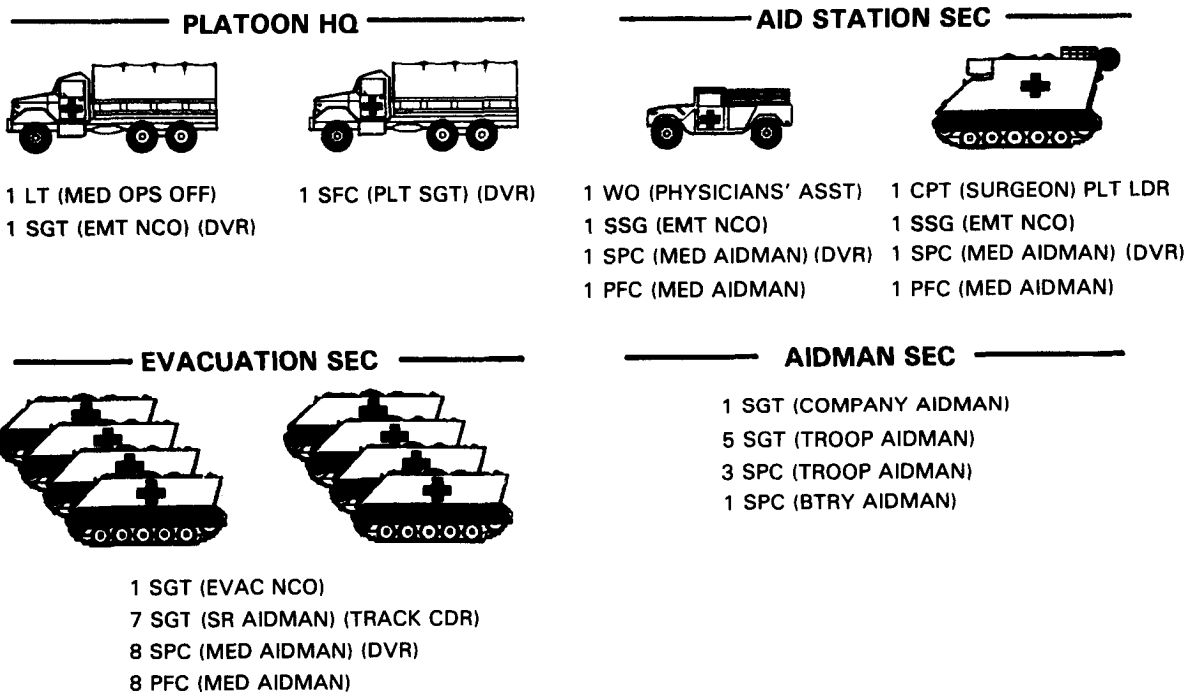

Figure 2-4. Squadron medical platoon.

CHAPTER 3

THE HEALTH SERVICE SUPPORT SYSTEM

3-1. Mission

The mission of HSS, to “conserve the fighting strength,” is accomplished by prevention, treatment, and evacuation. The HSS system provides medical care as far forward on the battlefield as the tactical situation will permit, allowing the maximum number of combat soldiers to return to duty (RTD) as early as possible.

3-2. Health Service Support, The Basic Doctrine

a. The objective of the HSS system is to reduce the incidence of disease and nonbattle injury (DNBI) through sound preventive medicine programs, to provide care and treatment for acute illness, injury, or wounding, and to promptly return to duty those soldiers who have recovered.

b. The major tenets of this doctrine are—

- Far forward medical treatment including advanced trauma management (ATM).
- Selectivity of RTD and nonreturn to duty (NRTD) patients at Echelon III medical units.
- Standardized Echelon I and II medical units under the modular medical support system throughout the division, corps, and communications zone (COMMZ).
- Standardized air and ground evacuation units are integrated under a single manager (the medical evacuation battalion [Evac Bn]).
- Flexible, responsive Echelon III and IV systems provided by four modularly designed hospitals and patient holding units.
- Enhanced ancillary and functional support systems with advanced technologies.
- A medical system that provides continuous medical management throughout all echelons of care and evacuation.

3-3. Principles of Health Service Support Operations

a. Conformity. Conformity with the tactical plan is the most fundamental element for effectively providing HSS. The HSS planner must participate in the development of the commander's operations plan to ensure adequate HSS at the right time and place. Medical intelligence data must be considered in all HSS planning see Appendix C and FM 8-10-8. All HSS planning is forward oriented and makes full use of the HSS system. A plan for the rapid reinforcement/replacement of forward echelons of the HSS structure is essential. For additional information on planning, refer to FM 8-55.

b. Continuity. The HSS system is a continuum from the forward line of own troops (FLOT) through the continental United States (CONUS) base; it serves as a primary source of trained replacements during the early stages of a major conflict. The medical structure is modular in design; procedures are standardized for flexibility, rapid reinforcement by identical modules, and simplified for tailoring a force for varying situations. The patient evacuation system (integrated ground and air) is an integral part of the HSS system; it has been organized to optimize resource use; it is staffed to provide continued care and maintain the physiology of the patient while being transported between MTFs.

c. Control. To ensure that the scarce HSS resources are efficiently employed and support the tactical plan, medical units are under the control of a single medical manager. Centralized control with decentralized execution permits the medical commander and his staff to rapidly tailor and adjust HSS assets. Assets can be realigned in response to major shifts in the location and volume of casualties; changes in supported unit composition and mission, and changes in the intensity of conflict. The modular medical support system provides the flexibility to task organize for any situation, or replace like units; however, optimum benefits are only derived through centralized control of all medical functions and subsystems.

d. Proximity.

(1) The location of medical assets in support of combat operations is dictated by the—

- METT-T factors.
- Requirements for far forward stabilization of patients.
- Early identification and forward treatment of RTD category patients.
- Forward orientation of evacuation resources, thereby reducing response time.
- Other logistical units/complexes.

(2) Medical commanders and staffs, through constant coordination, ensure that HSS units are not placed in areas that interfere with combat operations; or that are subject to direct intervention by enemy forces. Conversely, tactical commanders must realize the fact that fully committed HSS resources with a forward orientation will optimize their effectiveness.

e. Flexibility. Standardized, like-modules provide HSS from the FLOT to the rear boundary of the theater of operations (TO). The ability to rapidly shift HSS resources to areas of greatest need is a cornerstone of the modular medical support system.

f. Mobility. The mobility of HSS units organic to maneuver elements must equate to forces being supported. Major medical headquarters (HQ) in the TO (medical group [Med Gp], medical brigade [Med Bde], medical command [MEDCOM]) continually assess and forecast echelonment of medical units; through collective use of all transportation resources, they rapidly move units to best support combat operations.

3-4. System Design

The system is designed to acquire, triage, and provide medical care for all personnel operating in the division's sector. Health service support to the division is influenced by many considerations such as:

- The nature of operations, including the intensity of combat.
- The type of threat force to be encountered.
- The geographical area of operations.
- The potential for NBC attack.
- The climatic conditions and endemic disease health hazards.
- Air superiority.

3-5. Echelons of Health Service Support

Health service support is arranged in echelons (levels) of care (Figure 3-1). Each echelon of care reflects an increase in HSS capabilities while retaining capabilities found in preceding levels of care. The division contains two levels of care: unit level and division level. Echelon I HSS is provided by the medical platoon/section organic to combat battalions and some combat support battalions. It is supported by first aid in the form of self-aid/buddy aid and the combat lifesaver (CLS). Echelon II HSS is provided by medical companies of the FSB and MSB of the DISCOM (heavy) or the forward support medical company (FSMC) of the medical battalion (light). This level provides an increased medical treatment capability plus—

- Emergency dental care.
- X-ray and laboratory services.
- Patient holding facilities.
- Preventive medicine.
- Mental health services.
- Management of Class VIII (medical) supplies, equipment, and repair parts.

Nondivisional units operating in the division sector receive medical support on an area basis from the nearest medical treatment facility. For information on CLS training, see Appendix B.

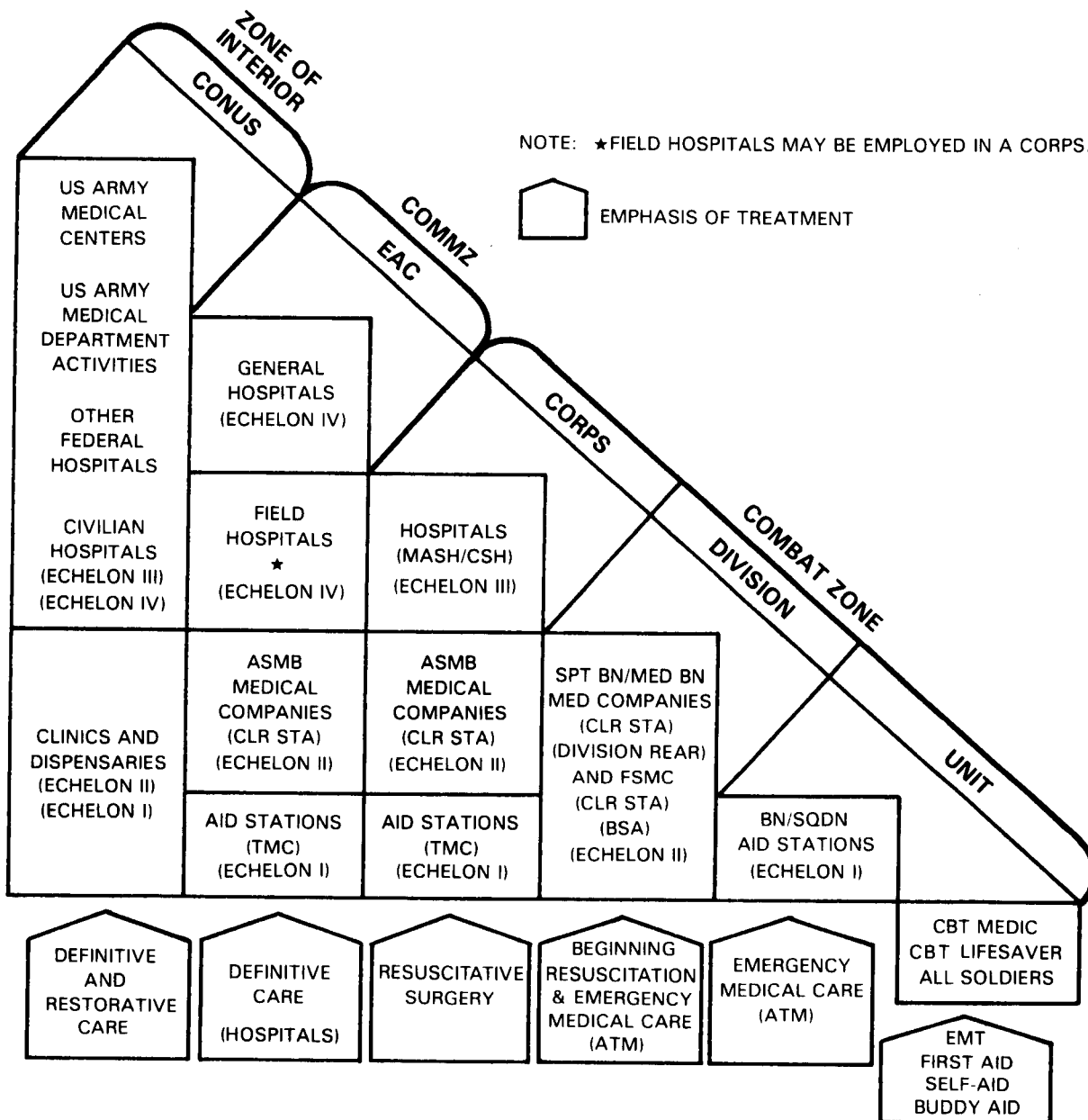

Figure 3-1. Echelons of health service support.

3-8. The Health Service Support Challenge

The HSS planner must be proactive rather than reactive to changing situations. He must shift medical resources as the tactical situation changes. Only in this way can the Army Medical Department (AMEDD) “conserve the fighting strength.” The challenges for HSS planners at the medical platoon level include the following elements:

a. Planning.

(1) Mission. Health service support planners must understand the tactical commander's plans, decisions, and intent. Health service support planning is an intense and demanding process. The actions of the HSS planner must be proactive, not reactive. The planner must know—

- will do.
- What each supported element
 - When it will be done.
 - Where it will be done.
 - How it will be done.

(2) Requirements. The HSS planner must plan to meet the requirements of—

- Acquisition and treatment of patients.
- Evacuation.
- Health service logistics.
- Dental services (available at supporting medical company).
- Veterinary services.
- Preventive medicine services.
- Mental health consultation services (available at supporting medical company).
- Command, control, and communications.

b. Prevention. The most effective, least expensive method of providing the commander with sustained combat power is prevention. Prevention begins with the individual soldier's awareness of the means to protect himself through health and personal hygiene, stress management, nutrition, physical fitness, and similar measures (soldier health maintenance programs). Prevention is enhanced by—

- The application of self-aid/buddy aid training programs.
- The CLS.
- Continuous interface with unit- and division-level medics.
- Division-wide preventive medicine (PVNTMED) programs.

- Combat stress control (CSC) programs.
- Leadership emphasis at all levels of command.

Ultimately, whether it is individual or collective, prevention is the unit commander's responsibility.

c. Far Forward Care. Far forward care is the identification and treatment of battlefield casualties as close to the forward edge of the battle area (FEBA)/FLOT as the tactical situation permits. This includes first aid, in the form of self-aid/buddy aid and the CLS, and unit-level medical support. The CLS, found in each squad, crew, section, or team, is responsible for the application of first aid measures with a higher degree of skill than self-aid/buddy aid. However, the CLS's primary role is the performance of his duties as a member of the squad, crew, section, or team, and his first aid duties are performed as the mission permits. Far forward care is provided to the front-line soldier by the combat medic attached to the maneuver platoon/company. More comprehensive care is provided by a physician-directed treatment squad (BAS) capable of administering initial resuscitation and stabilization (ATM) to battlefield casualties. This care maintains the physiology of wounded soldiers who are unlikely to RTD and allows for their rapid evacuation. The BAS treatment squad also treats soldiers with minor wounds/injuries and returns them to duty. A primary goal of unit-level medical care is that the combat medic reach the casualty and begin treatment within 30 minutes of wounding. This rapid application of medical treatment greatly enhances survivability.

d. Evacuation. Evacuation starts with the collection of the wounded soldier from the point of injury and continues with his rearward movement through the HSS system. An important element of the evacuation system is the medical care provided en route. Ground ambulances are used in the division area and, where indicated, are assisted by corps air evacuation assets. Normally, ground evacuation will be used for slightly wounded, ill, or injured soldiers who are expected to return to duty. Air evacuation will be used, when feasible, for seriously wounded, sick, or injured soldiers who are not expected to RTD. (Remember, air evacuation may be restricted but only to the extent other

aviation operations are restricted in the immediate area.) The responsibility for medical evacuation rests with the next higher echelon of HSS. For example, the medical platoon is responsible for evacuating patients out of the forward maneuver company/battery/troop area to the BAS. The medical company is responsible for evacuation from the aid station to the division clearing station (DCS). Plans for the use of nonmedical vehicles should be established and supplemented when casualties exceed the capability of medical evacuation assets. For specific information on the use of nonmedical vehicles for patient evacuation, see FM 8-10-6.

NOTE

It is the responsibility of unit commanders to ensure that wounded personnel are evacuated to established patient collecting points.

3-7. Modular Support System

Health service support to the division is provided by a modular support system (Echelons I and II) that standardizes all medical subunits within the division. The modular design provides duplicate systems at each level of care enabling the medical resources manager at the appropriate level to rapidly tailor, augment, or reinforce the battlefield in areas of most critical need. The system is derived by recognizing those common medical functions which are performed across the division and designing like subunits (modules) to accomplish those tasks. The modular medical support system is built around several modules. The modules are oriented to casualty assessment, collection, evacuation, treatment, and initial surgical intervention. When effectively employed, they provide greater flexibility and mobility, and the ability to rapidly tailor the medical force to meet changes in patient workloads and locations.

a. Combat Medic Module. The combat medical module consists of one combat medical specialist and his basic load of medical supplies and equipment. The combat medic is organic to the medical platoon/section of combat/combat support

battalions/squadrons and is attached to platoons, companies, batteries, or troops.

b. Ambulance Squad. An ambulance squad is comprised of four medical specialists and two ambulances (two teams). The squad provides evacuation of patients throughout the division and ensures continuity of care en route. Ambulance squads are organic to the medical platoon/section in combat battalions; selected combat support battalions: medical companies of the FSB and MSB (heavy); and the medical company of the medical battalion. Medical company ambulance squads are positioned to best support the maneuver battalions/surgeons. The medical platoon ambulance squads are likewise positioned to support the companies/batteries/troops.

c. Treatment Squad. This squad (BAS) consists of the medical platoon leader (a primary care physician), a PA, two emergency medical treatment (EMT) NCOs, and four medical specialists. The squad is trained and equipped to provide ATM to the battlefield casualty. To maintain contact with the combat maneuver elements, each squad has two emergency treatment vehicles (such as M577s). Each squad can split into two trauma treatment teams. The treatment squad is organic to medical platoons/sections in maneuver battalions and designated combat support units. It is the basic building block in the medical company. The treatment squad (treatment teams) may be employed almost anywhere on the battlefield.

d. Area Support Squad. This squad is comprised of one dentist trained in ATM, a dental specialist, an x-ray specialist, and a medical laboratory specialist. The squad employs light-weight specialized equipment which can be quickly and easily moved. The squad is organic to the medical company and, if necessary, may be deployed forward with the BAS to support the maneuver battalion.

e. Patient Holding Squad. This squad consists of two practical nurses and two medical specialists. The squad is capable of holding and providing minimal care for up to 40 RTD patients; however, in the light division this squad can only hold and care for 20 RTD patients. This squad is organic to the medical companies. A treatment

squad/team, an area support squad, and a patient holding squad are collocated to form the area support section (DCS).

f. Surgical Detachment. This detachment is a corps asset which must be collocated with the patient holding squad for support. It consists of two surgeons (a general surgeon and an orthopedic surgeon), two nurse anesthetists, a medical surgical (intensive care) nurse, two operating room specialists, and two practical nurses. The detachment is organized to provide early resuscitative surgery for seriously wounded or injured casualties, to save lives, and to preserve physical function. Early surgery will be performed whenever a likely delay in the evacuation of a patient threatens life or the quality of recovery. The TF surgical detachment will normally be employed in the division support area (DSA) but may be employed in the brigade support area (BSA) during brigade TF operations.

NOTE

The surgical detachment (squad) is organic to the medical battalion of the airborne and air assault divisions.

3-8. Health Care Logistics in the Combat Zone

a. Medical Resupply.

(1) Resupply of the CLS is accomplished through the normal resupply channels of the maneuver company. Combat lifesavers are resupplied in the same way combat soldiers are provided camouflage sticks, foot powder, or other individual health care items.

(2) Resupply of the combat medic is the responsibility of the BAS. This mission is handled and supervised by medical personnel. The combat medic requests his supplies from the BAS. This action is an informal request; it can be oral or written. The requests are delivered to the BAS by whatever means available. Usually this is accomplished by the driver or the medic in the ambulances returning to the BAS with patients. Ambulances then transport the supplies from the

BAS to the combat medics. This system is referred to as backhaul.

(3) Resupply of forward deployed BASS in a heavy division is the responsibility of the medical company of the FSB. In those divisions not under the MSB/FSB design, resupply of the BAS is the responsibility of the FSMC of the medical battalion. Medical supply personnel operate a resupply point for the BAS of the maneuver battalions based on supply point distribution. Backhaul of medical supplies using returning ambulances, both air and ground, is the preferred method of moving medical supplies to the maneuver battalions. If backhaul is not the method used, coordination for forward movement is the responsibility of the medical platoon leader of the maneuver battalion.

(4) Resupply of the medical companies in all divisions is performed by the division medical supply office (DMSO). The DMSO has the responsibility to provide medical supply support to all units within the division area. In contrast to the formal procedures normally associated with support between the combat zone (CZ) MEDSOM/MEDLOG battalion and the DMSO, requests submitted to the DMSO by division medical treatment elements are informal. Requests may come by message with returning ambulances (ground or air), by land line, or through existing frequency modulated (FM) command nets within the division. Requests for medical supplies from BASS and medical companies are filled or forwarded to the supporting CZ MEDSOM/MEDLOG battalion. The line of medical supply flow back to the requesting units will follow the principle of backhaul. Medical evacuation vehicles returning to the forward areas will be tasked with the transport of medical materiel. The DMSO uses supply point distribution at a site that is easily accessible to ground ambulances.

(5) Resupply of the DMSO is provided by the CZ MEDSOM/MEDLOG battalion.

(a) The DMSO, located in the division's medical battalion (divisions not under MSB/FSB design) or the MSB (divisions under MSB/FSB design division), is responsible for providing medical supply and medical maintenance

support to the medical treatment elements within the division. The division health services materiel officer (HSMO) executes health service logistics plans. He exercises his responsibilities by—

- Procuring, storing, and issuing Class VIII supplies for the division.

- Coordinating with the supported elements to determine requirements for Class VIII materiel.

- Developing and maintaining prescribed loads of contingency medical supplies. These loads should be based upon transportation and storage constraints as well as characteristics of the area of operations.

- Managing the division's health service logistics quality control program.

- Supervising unit level medical equipment maintenance performed by medical equipment repairer unit level.

- Monitoring the division medical assemblage management program.

- Coordinating logistical planning for preconfigured Class VIII packages.

- Calculating unit requirements for preventive medicine items such as foot powder, water purification supplies, malaria pills, and ear plugs.

(b) The reconstitution duties of the DMSO include—

- Reconciling by brigade the shortages in each medical company and treatment platoon as reported by the commander or platoon leader or the battalion headquarters element.

- Coordinating with the medical battalion commander or the MSB commander to obtain the number of modular medical systems required to field an operationally ready treatment facility.

- Coordinating with the CZ MEDSOM/MEDLOG battalion to monitor the status and number of modular systems due in.

- Coordinating with the division movement control center to move supplies from the MEDSOM/MEDLOG battalion. (The DMSO directs quick fixes using available assets and controlled exchanges for medical equipment to maximize the capability of returning trained soldiers to duty.)

- Alerting the appropriate company when modular systems are arriving.

- Allocating modular medical systems to the unit based on the commander's priorities. The DMSO coordinates through the division medical operations center (DMOC) with the division movement control center to identify backhaul ambulances to transport modular assemblages to the unit being reconstituted.

- Preparing the critical items listing and consolidating the critical shortages by brigade.

(6) Resupply of the CZ MEDSOM/MEDLOG battalion is received through the COMMZ MEDSOM/MEDLOG battalion or by direct shipments from CONUS. The CZ MEDSOM/MEDLOG battalion is normally under the direct command and control of the brigade headquarters. It provides medical supply, medical equipment maintenance, and optical fabrication services for units in the CZ area. The CZ MEDSOM/MEDLOG battalion establishes the Class VIII supply point in the corps area. Shipment of medical supplies forward is coordinated with the corps movement control center or accomplished by backhaul on medical vehicles (air or ground). Emergency resupply can be accomplished by air ambulances in the evacuation battalion.

b. Medical Maintenance. Division medical maintenance support is provided by DMSO medical maintenance personnel.

(1) Division medical equipment personnel provide unit level medical maintenance for repairs of their own equipment as well as area

support to units without such capabilities. The DMSO biomedical equipment maintenance NCO schedules, performs, and coordinates medical equipment maintenance for the FSMCs. Medical maintenance personnel from the DMSO are deployed forward as necessary to repair essential medical equipment. Maneuver BASs turn in their medical equipment in need of repair to the supporting FSMC. The FSMC will send this equipment to the DMSO when medical maintenance personnel are not deployed forward to the BSA. Medical equipment repairs beyond the capabilities of the DMSO are sent to the supporting corps MEDSOM/MEDLOG battalion for repair or the DMSO will request a mobile support team from the MEDSOM/MEDLOG battalion.

(2) The MEDSOM/MEDLOG battalion normally provides direct and general levels of maintenance support but may be directed to provide depot level support. Direct and general levels of medical maintenance provide the following services:

- Low-density lifesaving diagnostic equipment and therapeutic equipment-this type of medical equipment belongs to operating MTFs and is repaired or replaced immediately. The MEDSOM/MEDLOG battalion maintains

designated items under the Medical Standby Equipment Program (MEDSTEP). Direct exchange of low-density lifesaving diagnostic and therapeutic equipment through the MEDSTEP may be employed when repair time is determined to be excessive.

- Unserviceable and items, modules, or assemblies that are designed for discard-are replaced with serviceable items. The unserviceable item(s) are disposed of IAW disposition instructions.

- Items that cannot be repaired at the unit level-will be evacuated to the MEDSOM/MEDLOG battalions medical maintenance repair element. This element effects repairs if within their capability, and returns repaired items to user.

- Items that cannot be repaired or are not authorized to be repaired at the direct and general support levels-are evacuated to depot. Depot level maintenance is provided by the United States Army Medical Materiel Agency (USAMMA) or by designated MEDSOM/MEDLOG battalion as necessary when directed by the appropriate commander.

CHAPTER 4

DIVISION-LEVEL HEALTH SERVICE SUPPORT

Section I. DIVISION SUPPORT COMMAND

4-1. Mission

a. The DISCOM provides division-level CSS to all assigned and attached elements of the division. The DISCOM can, on a very limited basis, furnish CSS to nondivisional units in the division area.

b. The DISCOM commander is the principal CSS operator of the division and exercises command authority over organic units of the support command. The division G4 has coordinating staff responsibility for logistic planning he develops division-level plans, policies, and priorities. The relationship between the division G4 and the DISCOM commander must be close because of the similarities of interests. The G4's planning role does not relieve the DISCOM commander of his responsibility; he must advise the division staff during the formulation of plans, estimates, policies, and priorities.

c. The G3, G4, and the DISCOM commander normally locate the DISCOM elements in the DSA and the BSAs. The FSBs of the heavy divisions or the forward area support teams (FASTs) of the light divisions are positioned in the BSAs to best support committed brigades. The remaining DISCOM elements are located in the DSA to provide area support to divisional units in the division rear area and backup support to the FSBs/FASTs. Elements of the FSB/FAST may be forward of the BSA and other DISCOM units (MSB and light division equivalents) may have elements in the BSA.

4-2. Division Support Command Combat Service Support

The DISCOM provides the following CSS:

- Support of Class I (to include water purification, and limited distribution), II, III, IV, VI, VII, VIII, and IX supplies.

- Ammunition transfer points (ATPs) within the division.

- Intermediate direct support maintenance (IDSM) and limited backup unit maintenance support for all common and missile materiel organic to the division, and aviation intermediate maintenance (AVIM) support for all aviation materiel.

- Materiel management for the division.

- Surface transport for personnel, supplies, and equipment to accomplish division logistic and administrative missions, to include supplemental ground transportation to support emergency requirements.

- Supervision and coordination of DISCOM transportation operations.

- Automatic data processing (ADP) support for division logistic activities.

- Materiel collection and classification facilities.

- A limited capability to carry reserve supplies.

- CSS information and advice to the division commander and his staff, except for construction.

- Division-level and unit-level HSS on an area basis. This includes medical staff services, intradivision evacuation of patients, and unit-level maintenance of medical equipment.

- Planning, coordinating, and conducting rear operations within its assigned areas of responsibility.

- Request, store, and distribute unclassified maps.

- Interface and coordination with allied units.

4-3. The Supported Units

a. The maneuver units and their CS are the major focus of logistics support operations. In the combat battalion TF area, there are CS units performing many functions—FA, engineers, military intelligence units, and signal teams. There are more CS units in the brigade area; for example, air defense elements and FARPs for division and corps helicopters. Also, there may be more maneuver and CS formations in the division rear area.

b. All organizations require food, clothing, water, and the other essentials for human sustainment. Most require ammunition and fuel, as well as maintenance support. All require medical and personnel service support.

c. When fighting as part of a joint force or as part of a combined force, Army organizations will frequently support other services or allied forces. This support may range from petroleum distribution to emergency distribution of ammunition to allied artillery units.

4-4. Support Areas

The BSAs and DSAs are normally located toward the rear of the units they support (see Figure 4-1). If lateral and rear boundaries have not been defined, the support area is located as defined by the commander in coordination with higher and adjacent commands.

a. Brigade.

(1) The BSA is that portion of the brigade rear occupied by the brigade trains. When the battalion trains are echeloned, the BSA is the area occupied by the brigade trains and the battalion field trains. The BSA is generally located between the DSA and the battalion area; to provide protection against enemy indirect fire weapons, it is located approximately 25-30 kilometers behind the FLOT.

(2) Site location considerations for the BSA are the same as those for the battalion support area. A brigade does not have organic logistics support elements to support the battalion. Logistics support elements, located in the BSA, are from the

FSB and selected COSCOM resources as required. The FSB coordinates brigade logistics support with the brigade S4.

b. Division.

(1) The DSA is that portion of the division rear occupied by the DISCOM CP and organic and attached units. This area may also contain CS units and COSCOM elements operating in support of divisions. The division rear CP will normally collocate with the DISCOM CP to facilitate coordination, share area communication assets, and draw life support and security.

(2) The DSA is normally located between the division rear boundary and the BSA and adjacent to air-landing facilities and the MSR. The precise location is contingent on—

- Tactical plans.
- The location of COSCOM logistics support installations and the MSR.
- Terrain in the area of operations.
- Security considerations.
- Accessibility to lines of communications.

(3) All DISCOM units within the DSA are displaced when necessary to maintain continuous support to the division. The DISCOM commander recommends to the division rear CP the new locations and movement of DISCOM elements in the DSA: All DISCOM units must be capable of moving every 1 to 3 days.

(4) The DISCOM is organized to provide, within prescribed strength limitations, the most effective and responsive support to tactical units. To provide responsive support to the tactical commander, logistics, personnel, and HSS must be effectively organized and positioned where it is required. The DISCOM headquarters, along with the DMMC and the DMOC, ensures the best position of logistics support elements operating in the division area.

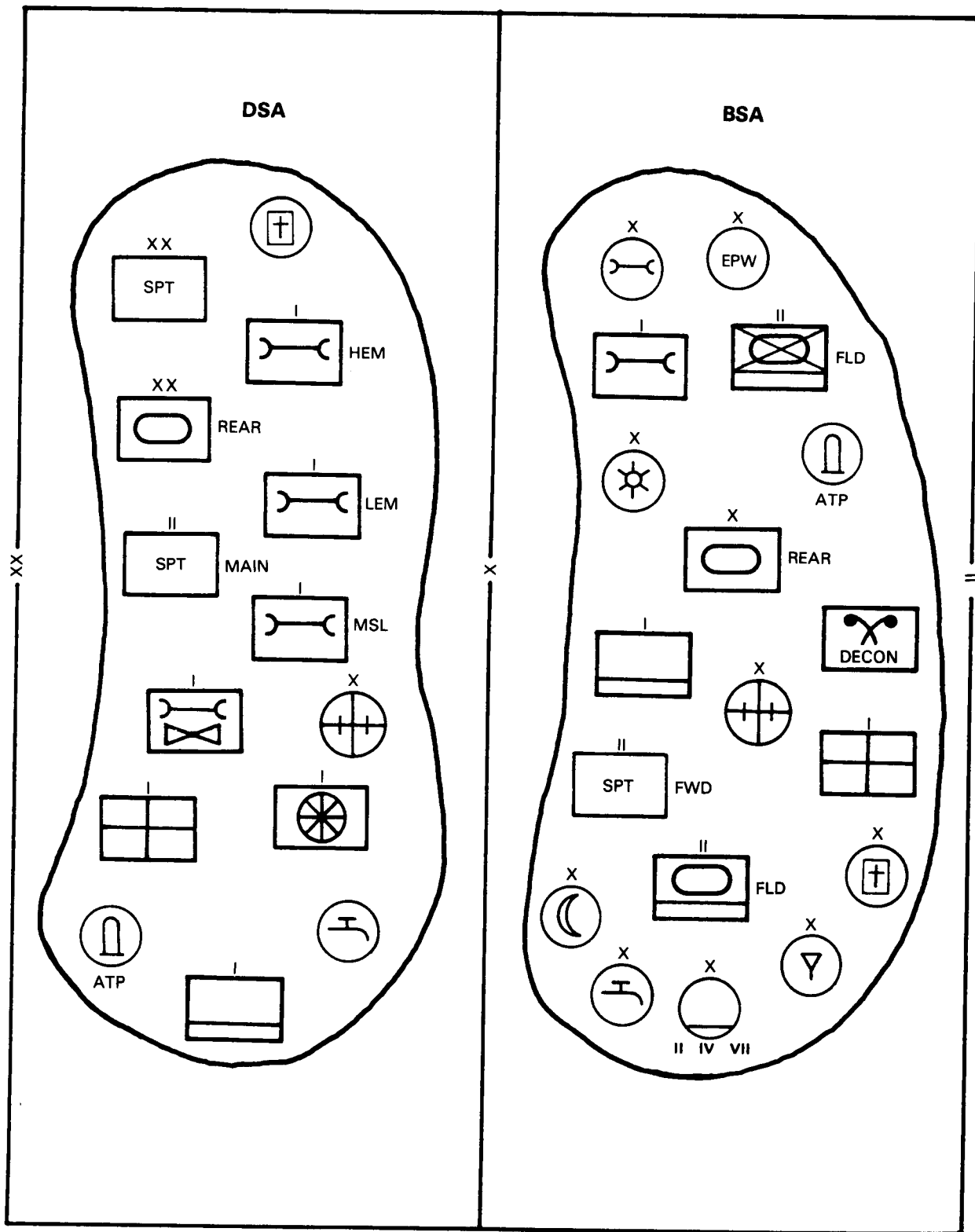

Figure 4-1. DISCOM units deployed throughout the DSA and BSA.

4-5. Division Support Command Headquarters and Headquarters Company

a. The DISCOM headquarters commands and controls organic and attached units of the DISCOM. It supervises and controls all logistical support and HSS operations within the division. It advises the division commander and staff concerning supply, maintenance, HSS, transportation, and field services functions in the division.

b. The headquarters company is responsible for providing administrative, supply, maintenance, and food service support for the company, DMMC, and DMOC. It provides administrative, food service, and water support to the divisional aviation maintenance company (AMCO). Supply, maintenance, and food service support is also rendered to the collocated division rear CP.

4-6. The Division Materiel Management Center

The DMMC is the primary logistics managing element in the division. The center receives policy and operational guidance from the DISCOM commander; it advises the commander on materiel (supply and maintenance, less medical) management. Activities include—

- Determining supply requirements.
- Ordering and directing the distribution of supplies received by the division (except Class VIII).
- Developing and supervising the division authorized stockage lists and the prescribed load lists.

- Maintaining the division property book and Army equipment status reporting data.

- Operating an integrated division maintenance management information program. The DMMC maintains maintenance status to include problems; maintenance requirements; and unit materiel readiness in the division.

4-7. Main Support Battalion

The MSB is organic to the heavy division DISCOM and is commanded by the MSB commander. The battalion provides division-level logistics support, HSS to divisional units located in the DSA, and reinforcing support to the FSBs.

4-8. Forward Support Battalions

The FSBs are organic to the heavy division DISCOM. These units provide division-level logistics support for the brigade and other division units located in the BSAs.

4-9. Deployment of Division Support Command Elements

The mission is the basic consideration in the location of CSS units and their facilities. Maintenance, supply, medical companies, and other service support units must be far enough forward to be responsive to the supported units. Maintenance, for instance, takes place not only in the BSA but wherever the weapon system is located, if possible. Mechanics and mobile equipment must be there to fix or replace components of the weapon systems. Additional considerations are enemy capability and their proximity to logistics support activities and other potential targets.

Section II. DIVISION SUPPORT COMMAND COMMAND AND CONTROL

4-10. Command and Control

command and control is the process through which the activities of military forces are directed, coordinated, and controlled to accomplish the mission. For the DISCOM commander, the C² function is a major challenge; his units are dispersed

over a large area of the battlefield. The C² process enables commanders to confirm the availability of logistics support resources; and institute accurate control procedures that ensure support is provided in the right quantities, to the right places, at the right times.

4-11. Organization

The division usually consists of six major subordinate commands: three maneuver brigades, a combat aviation brigade, the division artillery, and a DISCOM. To accomplish the logistics support mission, DISCOM units are deployed throughout the DSA and BSA. The organization of the DISCOMs is shown in Figures 4-2, 4-3, and 4-4.

C² functions through relationships that include-

- Higher organizations.
- Lateral organizations.
- Subordinate organizations.

4-12. Headquarters and Headquarters Company Relationships

a. Relationships used by the HHC and its staff are part of the C process. The HHC operates

b. The DISCOM commander's higher organizational relationship are with the division commander and staff. Lateral relationships are with the brigades and the DIVARTY. Subordinate relationships are with the MSB, FSB, AMCO, DMOC, and DMMC.

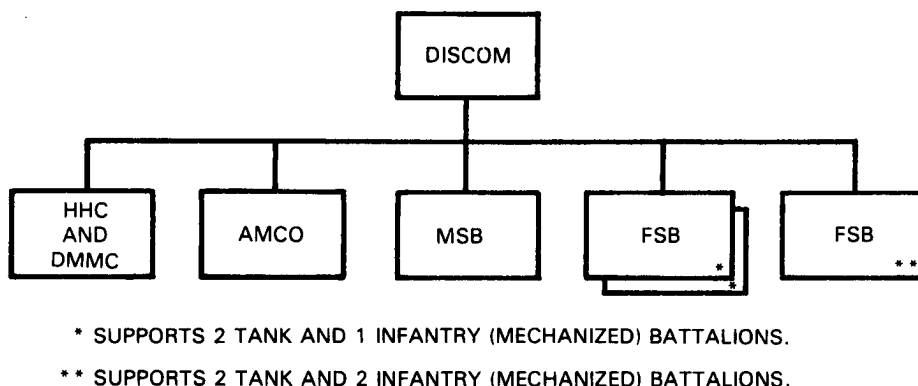

Figure 4-2. Organization of the DISCOM armored division.

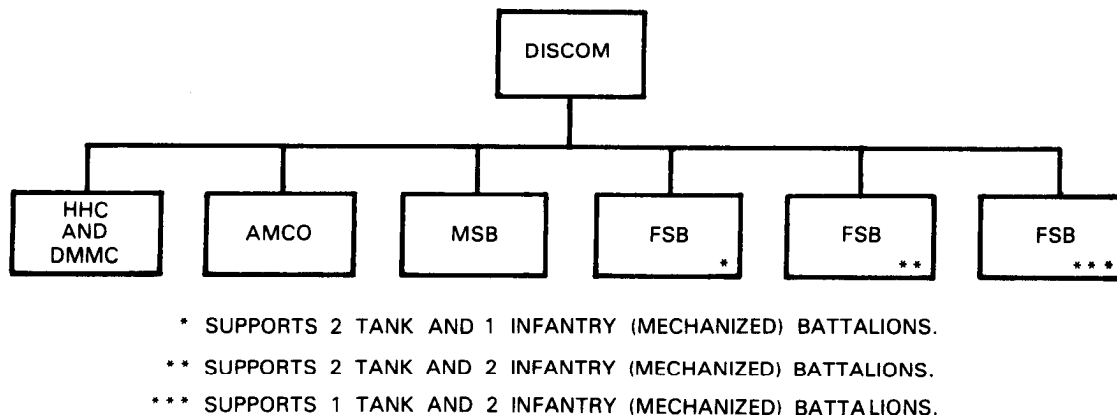

Figure 4-3. Organization of the DISCOM infantry (mechanized) division.

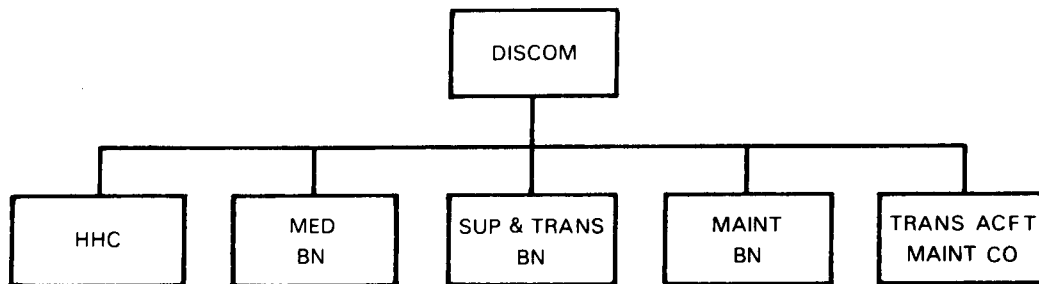

Figure 4-4. Organization of the DISCOM infantry (light) division.

Section III. DIVISION-LEVEL HEALTH SERVICE SUPPORT ARMORED AND MECHANIZED INFANTRY DIVISION

4-13. Structure

a. Division-level HSS (Echelon II) is provided to all divisional elements by the DISCOM support battalions medical companies. This level of care stabilizes the wounded soldier and evacuates him to the appropriate corps hospital. Additionally, they provide Echelon I care on an area basis to all units that do not have organic medical resources. Division-level HSS may be referred to as prehospital care. The medical companies are assigned to respective support battalions and are under the C² of the battalion commander; however, the DMOC retains technical control over all DISCOM medical assets.

b. Echelon II care is provided to divisional elements operating in brigade areas by medical companies in the FSBs. Normally, one FSB is assigned to support a committed brigade. The FSMC is usually located in the vicinity of other FSB elements in the BSA. The commanders of the FSMCs are also dual-hatted as brigade surgeons for the respective brigades.

c. The main support medical company (MSMC) of the MSB provides Echelon I and Echelon II care to all divisional elements operating in the DSA. The company operates and locates in the vicinity of other MSB elements in the DSA. The MSMC contains the centralized divisional PVNTMED, mental health, optometry services, and Class VIII supply assets. Currently, the division

medical supply office (DMSO) is a MSMC asset. Elements of the MSMC provide limited reinforcement, reconstitution, and augmentation to FSMCs operating in the BSA.

4-14. Division Surgeon

The division surgeon is the division commander's principal staff advisor on HSS aspects affecting the command. The surgeon is a special staff officer and functions under the general supervision of the G1. However, the surgeon has direct access to the division commander and his staff regarding HSS matters. The division surgeon also assumes technical control over all nondivisional medical units attached to the division. In coordination with the division G1, G3, and the DMOC, he develops medical plans, policies, programs, and procedures for the division commander. The duties and responsibilities of the division surgeon are outlined in FMs 8-10-5 and 101-5.

4-15. Division Medical Operations Center

The DMOC is a major staff section of the DISCOM HHC (Figure 4-5). The staff of the DMOC manages divisional medical assets and—

- Develops and maintains the medical troop basis, revising as required, to ensure task organization for mission accomplishment.

- Monitors medical training programs and provides information to the division surgeon.
- Coordinates and directs patient evacuation from division-level medical facilities to corps-level medical facilities.
- In coordination with the division surgeon and DISCOM S3, allocates division medical and corps augmentation assets to the division as required by the tactical situation.
- Coordinates (through the DISCOM S1) with the G1 for AMEDD personnel assignments and replacements.
- Coordinates and prioritizes medical logistics and logistical aspects of blood management for the division.
- Plans and coordinates division medical support to civil-military and inter-operability operations.
- Coordinates and manages disposition of captured medical material.
- Plans and coordinates, in coordination with the division surgeon, the PVNTMED and division mental health/combat stress missions.
- Coordinates and manages medical equipment maintenance programs for the division.
- Coordinates medical intelligence activities to include collection, limited processing, and dissemination.
- Plans and conducts HSS aspects of rear operations.
- Maintains contact with medical companies via FM or AM voice radio.

NOTE

For specific functions of the DMOC, SSS FM 8-10-3.

4-16. The Forward Support Medical Company

The FSMC of the FSB provides Echelon II HSS to those battalions with organic medical platoons. These companies provide both Echelon I and Echelon II HSS on an area basis to units without organic medical support operating in the BSAs. The FSMC establishes its treatment facility (clearing station) in the BSA, normally 15-20 kilometers from the FEBA.

4-17. Mission

The FSMC performs the following functions:

- Treatment of patients with minor diseases and illnesses, triage of mass casualties, advanced trauma management, and preparation of patients incapable of returning to duty for further evacuation.
- Ground evacuation for patients from battalion aid stations to the FSMC.
- Emergency dental care.
- Emergency medical resupply to units in the BSA.
- Medical laboratory and radiology services commensurate with division-level treatment.
- Outpatient consultation services for patients referred from Echelon I MTFs.
- Patient holding for up to 40 patients able to return to duty within 72 hours.
- Limited reconstitution, reinforcement, and augmentation to supported medical platoons.
- Echelon I HSS on an area basis to units without organic medical support.
- Tailgate medicine.

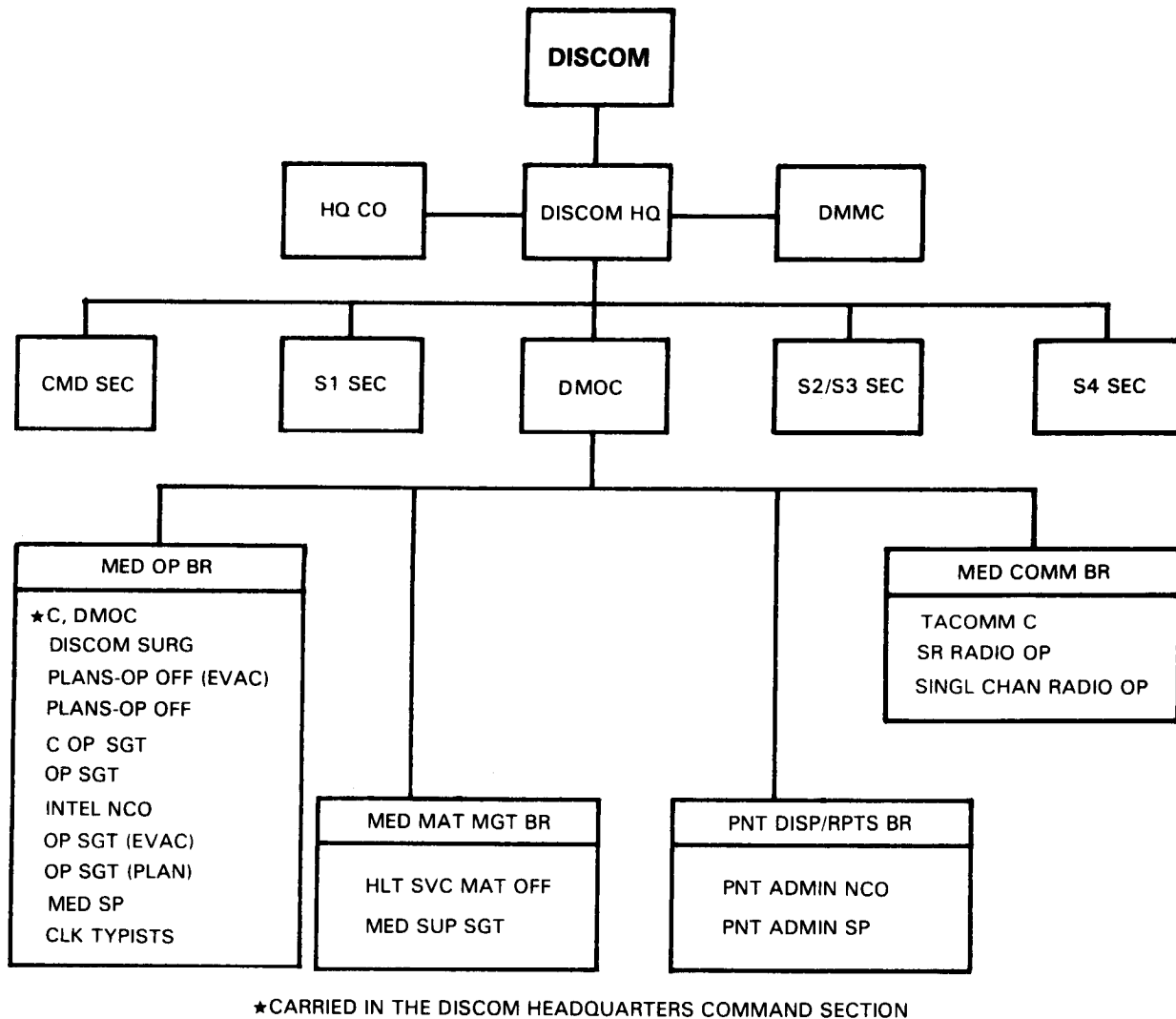

Figure 4-5. DISCOM HHC, DMMC, and DMOC.

4-18. Organization

The FSMC plays a vital role in manning the force by providing division- and unit-level HSS to all units operating in the supported brigade area on an area basis. As shown in Figure 4-6, the company consists of a company headquarters, treatment platoon, and ambulance platoon.

a. Company Headquarters. The company headquarters provides C² of the company and attached medical units. It provides administration,

general and medical supply, NBC defensive operations, and communications support. The headquarters is organized into command, supply, operations and communication, dining facility, and motor pool elements. The medical company commander, a physician, also serves as the brigade surgeon. As such, he must keep the brigade commander informed on the medical aspects of brigade operations and the health of the command. He regularly attends brigade staff meetings to obtain information to facilitate medical planning. Specific duties of the medical company commander include—

- Assuring implementation of the HSS section of the division SOP.

- Determining the allocation of HSS resources within the brigade.

- Supervising the technical training of medical personnel in the brigade area.

- Determining procedures, techniques, and limitations in the conduct of routine medical care, EMT, and ATM.

- Monitoring requests for aeromedical evacuation from supported units.

- Informing the division surgeon and the DMOC of the brigade's HSS situation.

- Supervising activities of subordinate battalion surgeons.

- Assuming technical supervision of all PAs organic to subordinate units in the absence of their assigned physicians.

During peacetime, a Medical Service Corps officer serves as company commander. He performs all of the nonphysician duties of the commander.

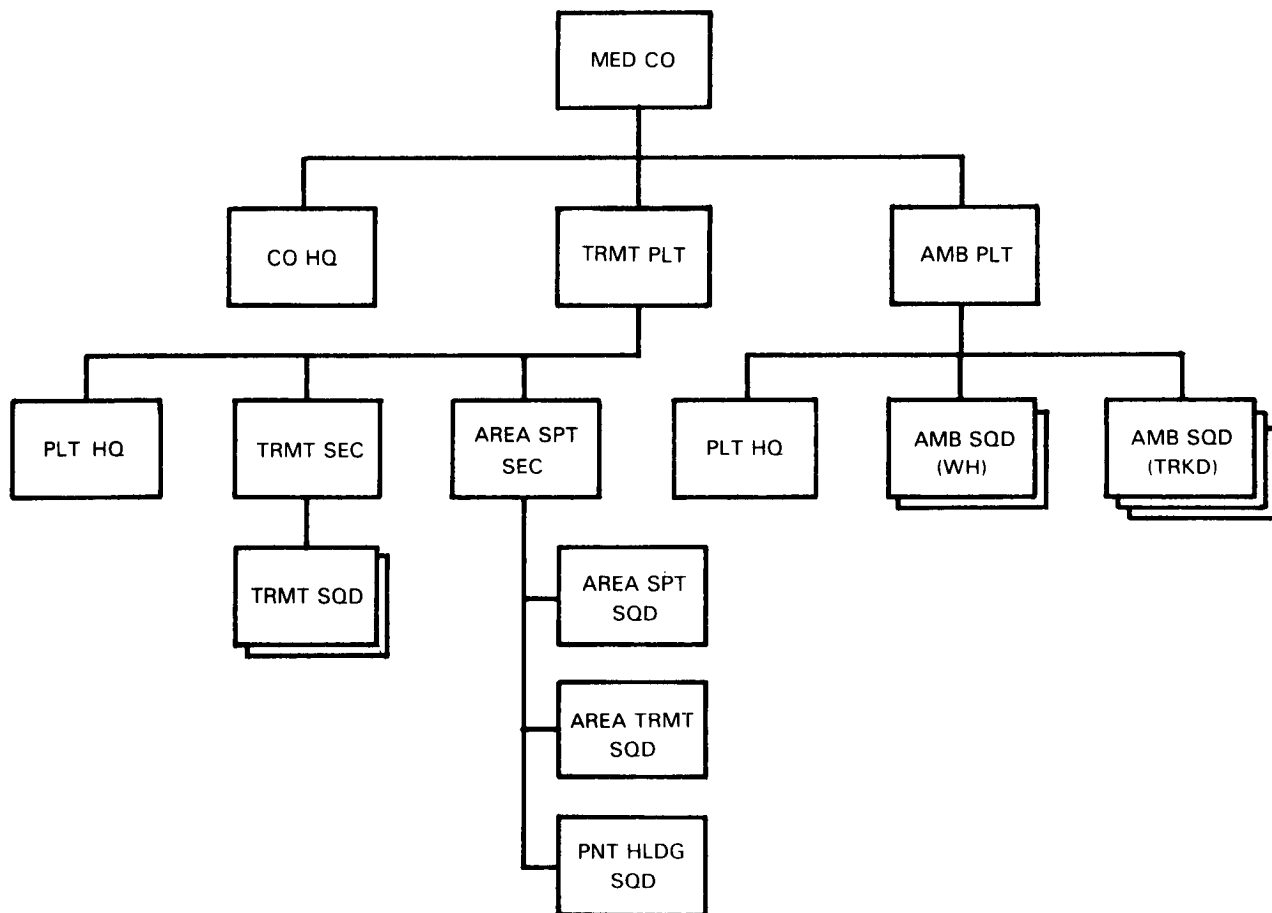

Figure 4-6. Medical company (heavy).

b. Treatment Platoon

(1) The treatment platoon operates the DCS in the BSA. It receives, triages, treats, and determines disposition of patients. The platoon consists of a platoon headquarters, an area support section, and a treatment section.

(2) The platoon headquarters is the C² element of the platoon. It determines and directs the disposition of patients and coordinates their further evacuation.

(3) The area support section operates the DCS. It consists of an area support treatment squad, an area support squad, and a patient-holding squad. These elements operate as a single medical unit and are not normally used to reinforce or reconstitute other units. The area support treatment squad is the base treatment element of the DCS. The squad consists of two teams which provide troop clinic services and ATM. When the DCS moves, one of the treatment teams along with elements of the holding squad serve as a jump element. They set up the new clearing station while remaining elements close out operations at the old site. The area support squad consists of the dental and diagnostic support elements of the DCS. The patient-holding squad operates a 40-bed facility for patients awaiting evacuation or expected to be returned to duty within 72 hours. The medical company has a temporary surgical capability when augmented by a corps-level surgical detachment.

(4) The treatment section consists of two treatment squads. Each squad employs treatment vehicles with medical equipment sets—two trauma sets and two general sick call sets. These squads provide troop clinic services and ATM. This section is oriented toward augmenting or reinforcing supported units medical elements and alleviating mass casualty situations. Each squad may be split into two treatment teams. (Remember, a treatment team consists of a physician or PA, an EMT NCO, and two medical specialists.) In exceptional situations, the medical company may deploy a treatment team forward to support a BAS.

c. Ambulance Platoon. The ambulance platoon performs ground evacuation from battalion aid stations to the DCS. It has a platoon headquarters and five ambulance squads—two with

wheeled ambulances and three with tracked ambulances. The headquarters provides C² and plans for the employment of the platoon. It coordinates support with the medical platoons of the supported maneuver battalions; plans ambulance routes; and establishes ambulance exchange points (AXPs) for ground and air ambulances as required. Each squad splits into two ambulance teams and provides evacuation from forward areas. Normally, a tracked ambulance team or squad is positioned with each supported battalion.

4-19. Operations

a. Plans. Planning for medical operations within the brigade area is done by the medical company commander and support operations section of the FSB. The company XO is the principal assistant to the company commander for the employment of the company. The basic considerations which influence the employment of medical assets within the brigade are—

- The brigade commander's plan.
- The anticipated patient load.
- Expected areas of casualty density.
- Medical treatment and evacuation resources available.

On the basis of these factors, planners determine the employment of ambulances, evacuation routes, AXP locations, and employment of the treatment teams. Coordination and communication between the medical company commander and the maneuver battalion medical platoon leaders are essential in developing an effective HSS plan. The medical company commander will consider all input provided by medical platoon leaders. The medical platoon leaders must become thoroughly familiar with the medical company commander's plan. The importance of medical platoon leader-medical company commander communications cannot be overemphasized.

b. Division Clearing Station Operations.

(1) Elements. The DCS in the BSA is operated by the medical company treatment

platoon. In addition, a team from the MSB medical company PVNTMED section and a behavioral science NCO from the MSB company mental health section may operate from the DCS. Also, operating at the DCS are other elements of the FSMC treatment section not deployed forward. During static situations, ambulance teams may be stationed at the DCS to provide routine sick call runs; also to provide emergency standby support to units operating in and around the BSA.

(2) Functions. The functions performed at the DCS are those discussed for the area support section of the treatment platoon. Seriously ill or wounded patients arriving at the DCS are given necessary treatment and stabilized for movement. Patients with minor injuries and illnesses are treated within the capability of the attending medical and dental personnel. These patients may be held for up to 72 hours for continued treatment or observation, returned to duty, or evacuated to a corps MTF. Other functions of the DCS include—

- Providing consultation, clinical laboratory, and x-ray diagnostics for unit physicians and PAs.

- Recording all patients seen or treated at the DCS and notifying the brigade S1 and XO's/first sergeants of supported CS and CSS units.

- Verifying the information contained on the field medical card of all patients.

- Monitoring patients when necessary for NBC contamination before medical treatment.

- Ensuring NBC patients are properly handled.

(3) Area support. In addition to providing division-level support for units in the brigade area, the DCS provides unit-level support to units in the BSA on an area basis.

(4) Preventive medicine. A PVNTMED team from the division PVNTMED section of the MSB ensures that PVNTMED measures are implemented to protect against food-, water-, and arthropod-borne diseases and environmental injuries (such as heat and cold). Specifically, the team—

- Performs environmental health surveys and inspections.

- Monitors water production and distribution within the brigade area.

- Investigates incidents of food-, water-, arthropod-borne, zoonotic, and other communicable diseases.

- Helps train unit field sanitation teams.

- Assists in identification/evaluation of NBC contamination in water supplies.

The team emphasizes preemptive action. In past conflicts, more soldiers have been rendered ineffective from DNBI than from combat wounds. The team cannot wait until problems appear to take action. Unit commanders and leaders must plan for and enforce field hygiene and sanitation procedures (FMs 21-10 and 21-10-1).

(5) Mental health. A member of the MSB mental health section functions as the brigade combat stress control coordinator. As such, he advises the brigade surgeon on mental health considerations. He keeps abreast of the tactical situation and plans for battle fatigue/neuropsychiatric (BF/NP) care when maneuver units are pulled back for rest and recuperation. At the DCS, he assists in patient triage and ensures BF/NP patients are handled properly. Treatment of battle fatigue follows these guidelines.

- Mild cases are given a brief respite of 1 to 6 hours of comfort and reassurance and are return to their units.

- Moderate cases may be assigned work at a logistics facility in the BSA for 1 to 2 days. During this time, however, they must be under medical supervision; the medical company remains responsible for such services as feeding these patients. Moderate cases may also be held at the holding facility, but separated from other patients, if space is available.

- Severe cases may be held in the DCS holding facility for up to 48 hours if behavior is not too disruptive. The combat stress control

company (CSCC) provides guidance to DCS personnel on treating BF/NP patients (see FM 8-51). It also helps the attending physician coordinate RTD of patients fit to perform their duties.

- Severe cases beyond the ability of the DCS to manage are evacuated to the MSB DCS or a corps hospital as conditions permit. Physical restraints are used during transport when necessary.

(6) Patient weapon and ammunition. The patient's individual weapon and ammunition should be retained by his unit. If weapons or ammunition arrive at the DCS, they are collected and given to the brigade S4 or the supported CS/CSS unit's designated representative, or they are disposed of according to command SOP.

c. Evacuation.

(1) Team locations. Evacuation from the BASS is normally provided by the FSMC ambulance platoon and a forward air ambulance team of the supporting corps air ambulance company. These assets also support other units in the brigade area on an area basis. Typically, one team from the ambulance platoon is field sited at each BAS. The other ambulances of the platoon are located at AXP's, designated patient collecting points, or at the DCS.

(2) Air ambulance. An air ambulance team of the corps air ambulance company may be field sited at the BSA. The team leader is involved with planning on employment of air evacuation assets; and obtaining airspace management information. He coordinates aviation support requirements and airspace C² matters with the brigade S3 (air). The team evacuates urgent patients from as far forward as the tactical situation will allow aviation assets to operate to the BSA/DSA DCS.

(3) Alternate evacuation modes. If medical company evacuation assets are overwhelmed, additional assets may be requested from MSMC or the corps through the DMOC. Another alternative is the use of nonmedical air or ground transportation assets. This support is normally coordinated by the company XO with the FSB S3 section. When possible, nonmedical assets

are augmented with medical personnel and supplies to provide en route care.

(4) Ambulance shuttle system. To keep tracked ambulances from having to spend too much time evacuating patients to the BSA, an ambulance shuttle system may be setup between the DCS and BASs. Such a system uses ambulance exchange points (AXPs). AXP's are positions where patients are exchanged from one ambulance to another usually from tracked ambulances to wheeled ambulances. AXP's are normally preplanned and moved often. Use of AXP's allows ambulances to return to their supporting positions more rapidly. This is desirable since the crews are more familiar with the roads and the tactical situation near their bases of operations.

(5) Ambulance relay points. Another form of ambulance shuttle system involves the use of ambulance loading points and relay points. In this system, ambulances are stationed at loading points ready to receive patients. Ambulances are also stationed at relay points ready to replace ambulances leaving loading points to evacuate patients. Control points may also be used at crossroads or junctions to direct empty ambulances from relay points to loading points.

4-20. Class VIII Supply

Medical supplies, equipment, and repair parts are provided through medical logistics channels. Unit- and division-level medical elements carry a 5-day stockage of medical supplies. During combat operations, the FSB medical company receives preconfigured medical supply packages from the DMSO. As medical units consume their initial issue, they request resupply from the next higher medical element. Medical supplies will normally be backhauled to the BAS using FSMC ambulances. During combat, a PUSH resupply system should be used. This system is preplanned between the medical platoon and medical company and provides planned amounts of supplies to the BAS at planned intervals without a supply request. The PUSH resupply system should be planned and coordinated before combat operations begin. The medical platoon leader must ensure that his resupply needs are known by the supporting FSMC, the DMSO, and the DMOC.

4-21. The Main Support Medical Company

The MSMC provides unit- and division-level HSS, on an area basis, to units operating in the DSA that are not otherwise provided this support. The

medical company is organized with a company headquarters, an ambulance platoon, a treatment platoon, a PVNTMED section, an optometry section, a mental health section, and a division medical supply section. See Figure 4-7.

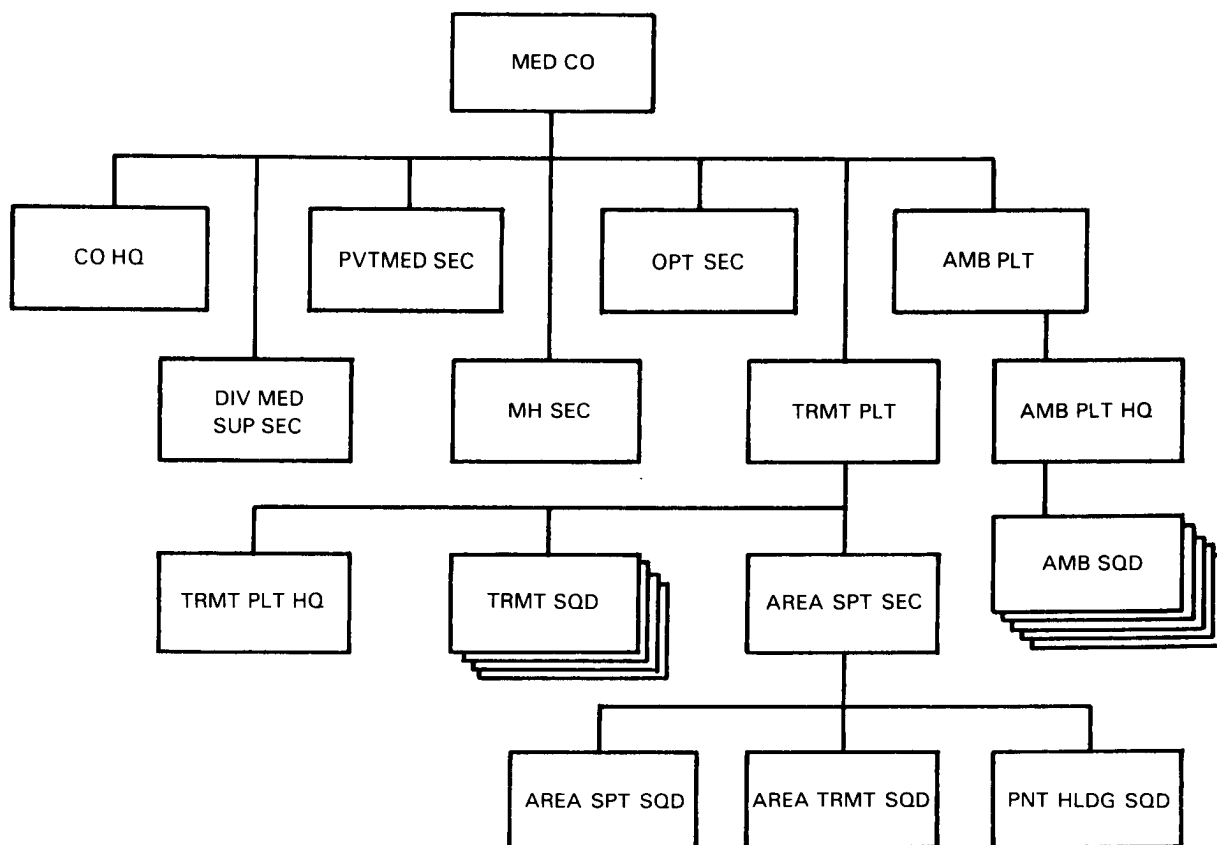

Figure 4-7. Typical organization of main support medical company.

4-22. Capabilities

The MSMC provides—

- Facilities for receiving and sorting patients.
- Facilities for providing medical treatment for all classes of patients in the division

rear area and those evacuated from medical companies in the brigade area.

- Ground ambulance evacuation from medical companies, unit-level medical treatment elements, and other units operating in the division rear area which do not have organic ambulances.

- Emergency dental care, preventive dentistry, and consultation services.
- Emergency psychiatric treatment and mental health consultation services.
- Division-level medical resupply support; supervision of medical equipment maintenance and medical equipment repair parts support to all division and attached medical units.
- A patient-holding facility of 40 cots for patients who do not require hospital treatment and who are expected to be returned to duty within 72 hours.
- Limited laboratory, pharmacy, and radiology services.
- Unit-level HSS to units operating in the DSA that are not otherwise provided this support.
- Preventive medicine surveillance, inspections, and consultation service.
- Optometric support limited to eye examinations, spectacle frame assembly using presurfaced single-vision lenses, and repair services.
- Limited reconstitution, reinforcement, and augmentation to FSMCs.

4-23. Operations

The MSMC is located in the DSA.

a. Treatment. The treatment platoon performs triage and provides medical treatment within its capabilities. It returns patients to duty, transfers them to the holding platoon, or arranges for their evacuation to a combat zone hospital.

b. Holding. The holding platoon has a 40-cot holding capability. This capability is used only if the battle environment is conducive to holding patients at this level and the patient can be returned to duty within 72 hours.

c. Evacuation. Medical evacuation is provided for patients by the ambulance platoon of the MSMC. This platoon evacuates patients, on an

area basis, from unit-level treatment facilities and other units within the DSA to the treatment platoon. It may provide ground ambulance evacuation of patients from the FSMC to the MSMC. Since MSMC evacuation assets are limited, corps ground ambulances are positioned to assist in FSB to MSB evacuations. Ambulances may bypass the MSMC and evacuate patients directly from the FSMC to a corps hospital. Air and ground evacuation from the DCSs to corps hospitals is provided by the corps medical brigade/group.

d. Supply. A 5-day level of medical supplies is maintained by unit- and division-level medical elements. Battalion aid stations submit routine medical supply requests to the DMSO. Emergency requisitions are submitted to the supporting medical company; these requests are filled or are forwarded to the DMSO. Requests are filled by the DMSO and shipped to the requestor, or are requested from the supporting corps MEDSOM/MEDLOG battalion. Shipment of medical supplies forward is coordinated with the movement control officer or accomplished by backhaul of returning ground and air ambulances.

e. Maintenance. Medical maintenance support is provided by the medical equipment repairer assigned to the medical company. Higher-level medical maintenance support is provided by the corps MEDSOM/MEDLOG battalion. Single-vision lens optical fabrication support is provided by the medical company, Multivision lens fabrication support is provided by the corps MEDSOM/MEDLOG battalion.

4-24. Organization

a. Company Headquarters. The company headquarters provides C of the MSMC and attached units. The headquarters consists of a command element, supply element, motor pool element, and food service element. The company headquarters is staffed with a company commander, a medical operations officer, a first sergeant, and a unit clerk.

(1) Company commander. The company commander (a physician) plans, directs, and supervises the operations and employment of the company. He is responsible for training, discipline, billeting, and security of the company.

(2) Medical operations officer. The medical operations officer coordinates the functions of the company and assists the commander in company operations. He coordinates the functions of the company. During peacetime, a medical operations officer commands the company.

b. Ambulance Platoon. The ambulance platoon is staffed with a platoon leader, platoon sergeant, aid/evacuation NCO, and ambulance aid/drivers. The ambulance platoon employs five ambulance squads, with only wheeled ambulances. The ambulance platoon may provide reinforcements or replacements for ambulances of FSB medical companies.

c. Treatment Platoon. The treatment platoon consists of a platoon headquarters, a treatment section, and an area support section.

(1) Platoon headquarters. This office provides C² of the treatment platoon; it provides communications operations for the company. It determines and directs disposition of patients received from the brigade area. The platoon headquarters coordinates patient evacuation as required. It is staffed with a platoon leader, a medical operations officer, a platoon sergeant, patient administration specialists, a single channel radio operator, and a tactical communications system operator/mechanic.

(2) Treatment section. The treatment section of the MSMC employs four treatment squads (eight teams) instead of the two squads found in the FSMC. The personnel structure of each treatment squad is the same as is found in the FSMC and BAS treatment squads.

(3) Area support section. The capabilities and personnel structure of the MSMC area support section are identical to those of the FSMC area support section.

d. Optometry Section. The optometry section provides optometric services, to include routine eye examinations and refractions; fabricates presurfaced, single vision lenses; and provides optical repair services. It is staffed with an optometrist, an optical laboratory specialist, and an eye specialist.

e. Mental Health Section. The mental health section provides division-wide mental health services to minimize preventable mental health problems and associated personnel losses to the division. It is staffed with a psychiatrist, a psychologist, a social worker, and behavioral science specialists.

f. Preventive Medicine Section. This section provides PVNTMED services to the division to include environmental health surveillance, inspections, and consultation services. It is staffed with a PVNTMED officer, an environmental science officer, a PVNTMED NCO, a PVNTMED sergeant, and PVNTMED specialists.

(1) Preventive medicine officer. The PVNTMED officer plans and directs the division PVNTMED program and supervises the activities of the PVNTMED section.

(2) Environmental science officer. This officer plans, manages, and supervises the identification and evaluation of environmental health conditions.

(3) Preventive medicine enlisted personnel. The PVNTMED enlisted personnel perform environmental health surveys, inspections, and laboratory procedures. They conduct food-, water-, and arthropod-borne, zoonotic, and other communicable disease investigations. They also conduct training for unit field sanitation teams.

g. Division Medical Supply Section. This section maintains a 5-day stockage level of division-level medical supplies. Requests for medical supplies from the FSMCs and BASS are filled or forwarded to the supporting corps MEDSOM/MEDLOG battalion. This section provides maintenance on medical equipment in the DSA. It is staffed with a health services materiel officer, a medical supply supervisor, a medical equipment repairer, advanced, a pharmacy NCO, and medical supply specialists.

(1) Health service materiel officer. The HSMO supervises and controls medical supplies and medical equipment maintenance support to units in the division.

(2) Medical equipment repairer, advanced. This specialist performs periodic scheduled services and repairs on all types of

medical equipment. He supervises medical equipment repair functions.

Section IV. DIVISION LEVEL HEALTH SERVICE SUPPORT LIGHT INFANTRY, AIRBORNE, AND AIR ASSAULT DIVISION

4-25. General

Division-level health service is concerned primarily with evacuating and treating patients from unit-level MTF. It provides unit- and division-level HSS (including tailgate medicine) on an area basis to units without organic medical support. Through provisions of division-level HSS, patients are returned to duty; held for further treatment if they can be returned to duty within 72 hours; or evacuated to a corps level medical treatment facility. This support is provided in the DSA and BSA by the DISCOM's medical battalion.

4-26. Organization

a. The DISCOM medical battalion is organized to provide division-level HSS for the entire division. The battalion provides unit-level medical support on an area basis for assigned and attached units operating within the division's area of operations. The medical battalion (Figure 4-8) is modular in design and consists of a headquarters and support company (HSC) and three FSMCs.

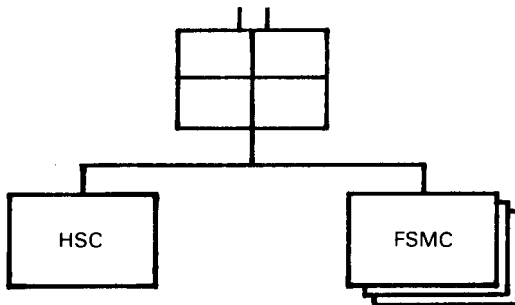

Figure 4-8. Medical Battalion, Division Support Command, Infantry Division (Light).

b. The division is oriented primarily to defeating light enemy forces in a LIC, while retaining utility for employment in other scenarios. The medical battalion is designed to be employed in LIC environments. However, the modular design readily lends itself to quick-fix augmentation. With sufficient additional organizational support, medical ground evacuation, and medical treatment modules, the battalion can support the division employed in other scenarios.

4-27. Mission

The mission of the medical battalion is to maximize the RTD rate and to conserve the human component of the division's weapons system. Its functions are centered around three basic principles: treat and RTD, treat and hold (up to 72 hours), and treat and evacuate. The battalion provides division-level HSS; medical staff advice and assistance and unit-level HSS for all assigned and attached units of the division. Specific functions of the battalion include the following

- Operates DCSs with limited holding capability.
- Provides ground ambulance evacuation of patients from unit-level treatment stations.
- Provides division-wide medical supply and medical equipment maintenance service.
- Provides unit-level HSS on an area basis to units without organic medical elements.
- Provides limited optometry services.
- Provides emergency dental service.
- Provides limited neuropsychiatric service and consultation service for patients referred from unit-level medical treatment elements.

- Provides PVNTMED service.
- Reinforces/reconstitutes unit-level HSS elements to include medical supervision for PAs without assigned supervisory physician(s).

4-28. Command and Technical Relationships

The medical battalion commander exercises C² over the battalion, and operational control over corps medical units attached to the division. As division surgeon, he exercises technical supervision over all HSS elements of the division.

a. The HSC commander exercises C² over all elements assigned to his company, less operational control of the battalion headquarters element.

b. The FSMC commander exercises C² over all elements of the FSMC. As brigade surgeon, he exercises technical supervision over all HSS elements of the brigade.

c. The commander exercises C² over subordinate elements. He makes all fundamental decisions in his area of responsibility. When tactically feasible, he consults with subordinate commanders before making decisions.

d. The medical battalion staff provides the commander with timely information, it prepares, analyzes, estimates, and recommends courses of actions. The staff translates the commander's decisions into instructions and orders, issues the orders, and supervises their execution. Staff members resolve problems and make recommendations within their functional areas based on the commander's guidance/SOP. The commander, however, identifies goals, announces the goals and takes the initiative. Once the commander decides what must be done, the staff supports the decision and ensures that it is carried out.

e. Medical company commanders are working physicians. They command their company from a location where they can best access and influence the HSS operation. These commanders use verbal orders, radio and wire communications between themselves, their platoon leaders, and supported elements.

f. The medical battalion is under the C² of the DISCOM commander. The medical battalion commander (division surgeon) is the primary medical staff officer of the DISCOM. The battalion's S2/S3 assumes the planning and operations functions that have traditionally been associated with the division surgeon's section. The medical battalion commander, his staff, and subordinate commanders employ direct channels of communications on technical matters.

g. The commander of the support company provides technical advice to supported units in the DSA. Commanders of FSMCs provide technical advice to respective brigade commanders and serve as brigade surgeons.

h. A request for HSS flows from the requesting unit to the supporting medical company, and from medical companies to the medical battalion S2/S3 section.

4-29. Communications

For rapid response to changing threats, the HSS system employs AM/FM voice and data link communications, together with automatic data processing and line communications to the maximum extent available. These systems are required for the effective control of medical units, patient evacuation, and medical regulating.

4-30. Medical Battalion Command/Operations Net

Communications are essential for gathering data, planning operations, and supervising mission performance. Effective management depends on communications to keep abreast of changing situations and HSS requirements. The medical battalion headquarters and its companies depend on both AM and FM radios and area communications systems to conduct operations. The medical battalion command/operations FM radio net is shown in Figure 4-9. Stations in this net are discussed below. The battalion headquarters and support medical company's wire net is shown in Figure 4-10.

a. *Station A.* This station is the S2/S3 operations center which acts as the net control

station. The S3 uses this station to control the entire operations of the medical battalion on a routine basis.

b. Station B. This station is the commander's communications means for C², and for division surgeon's traffic with division headquarters.

c. Station C. This station is the S2/S3 officer's means of controlling battalion operations while traveling.

d. Stations D, E, F, G and H. These stations are used by the battalion commander and his staff to maintain contact with subordinate companies.

e. Station I. This station is used by the division PVNTMED officer.

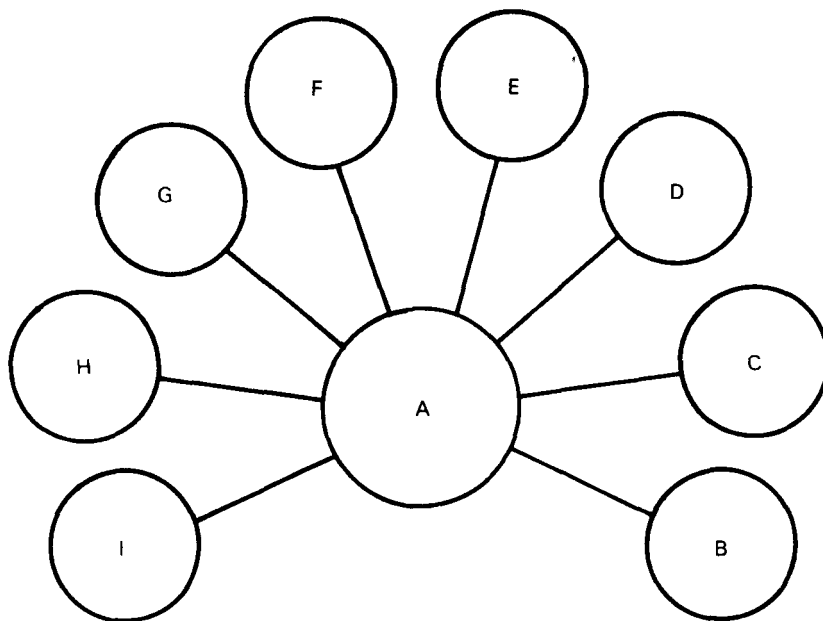

- A. MEDICAL BATTALION OPERATIONS (NCS)
- B. BN CDR
- C. S2/S3 (MOBILE)
- D. BN XO
- E. CDR, SPT CO
- F. CDR, FSMC "A"
- G. CDR, FSMC "B"
- H. CDR, FSMC "C"
- I. PVNTMED OFF

Figure 4-9. Command/operations net.

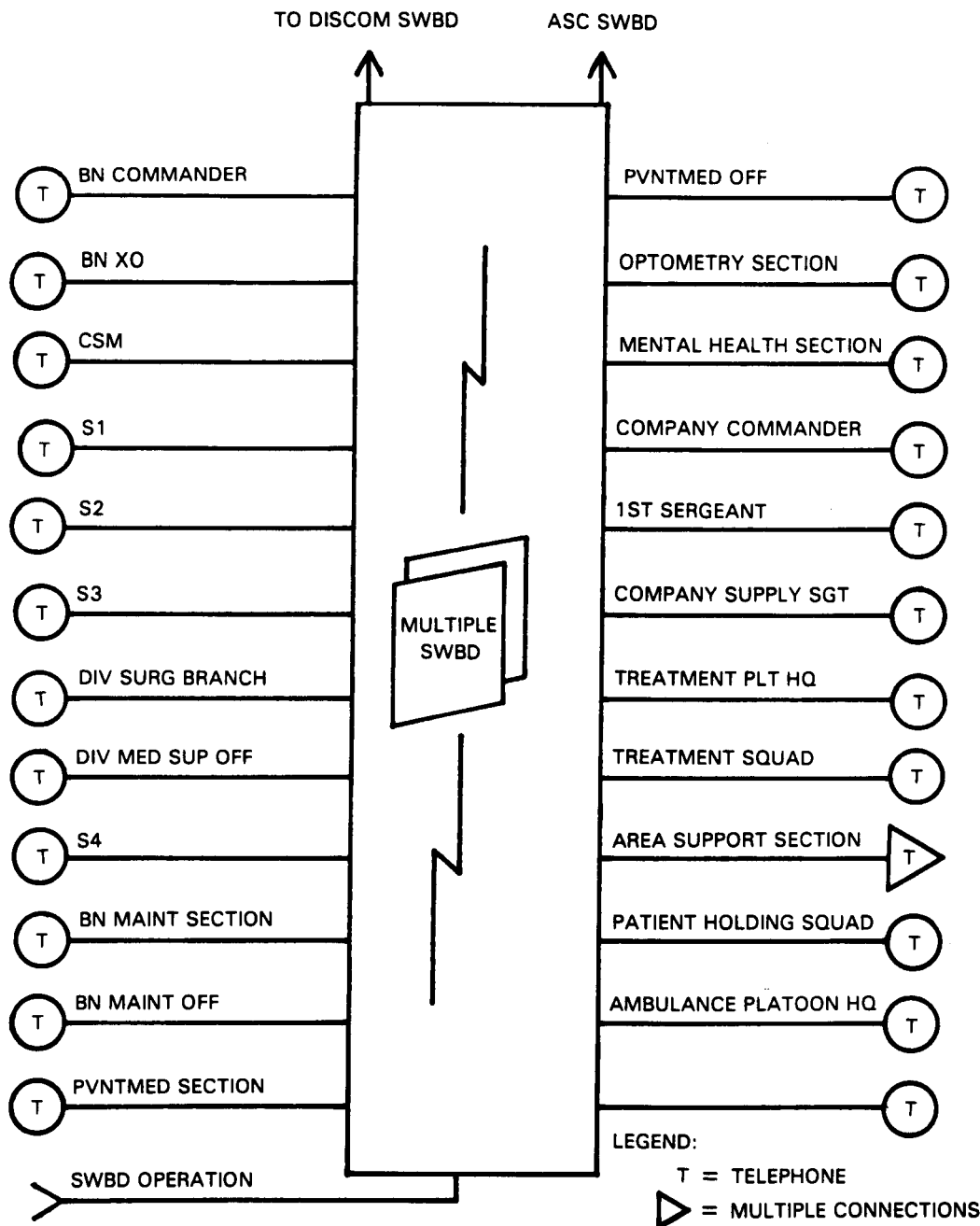

Figure 4-10. Headquarters and support company wire net.

4-31. Long-Range Communications

The medical battalion employs long-range communications systems to facilitate patient management, air and ground evacuation, and medical regulating within and out of the division. These systems include the Tactical Army Combat

Service Support (CSS) Computer System (TACCS), the wire telecommunications systems, and a high frequency (AM) radio system with voice and data-link capability. The supporting corps medical brigade/group and the battalion are linked by these systems. The medical battalion's high frequency AM radio net is shown in Figure 4-11.

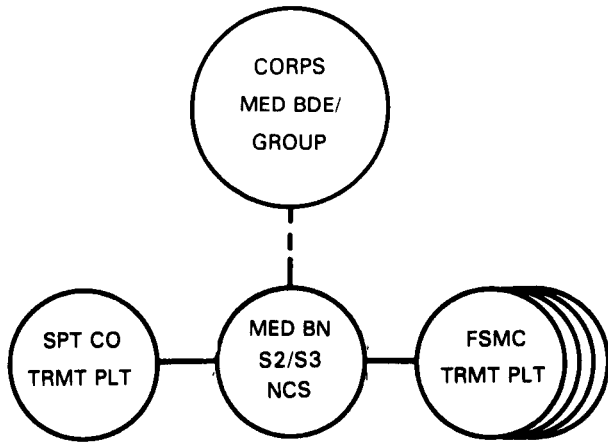

Figure 4-11. Medical battalion AM net.

4-32. Support Company Communications

The Support Company employs AM and FM radios. These radios are used to maintain an information link for C²; to provide information on patient evacuation and to maintain the command net. The FM short-range radio nets are used for C² within the company and for communication with supported units. The high frequency radio (long-range) net is required for medical regulating and aeromedical evacuation coordination. The Support Company's radio net is shown in Figure 4-12. Its wire net is shown along with the battalion headquarters in Figure 4-10.

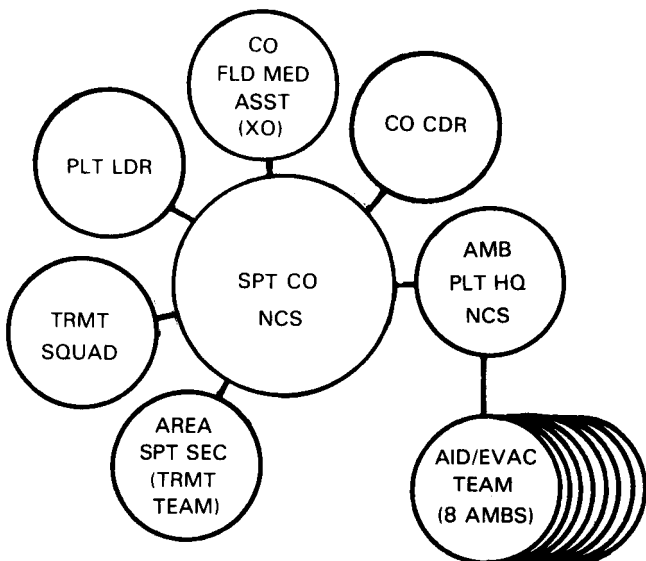

Figure 4-12. Support company tactical radio net (FM).

4-33. Forward Support Medical Company Communications

The three FSMCs have identical TOEs. Each FSMC employs AM and FM radios. Communication requirements for the FSMC are similar to those of the headquarters support medical company. Additionally, the FSMC is required to establish and maintain tactical communications with forward HSS elements of the maneuver brigade it supports. The FSMC radio and wire nets are shown in Figures 4-13 and 4-14.

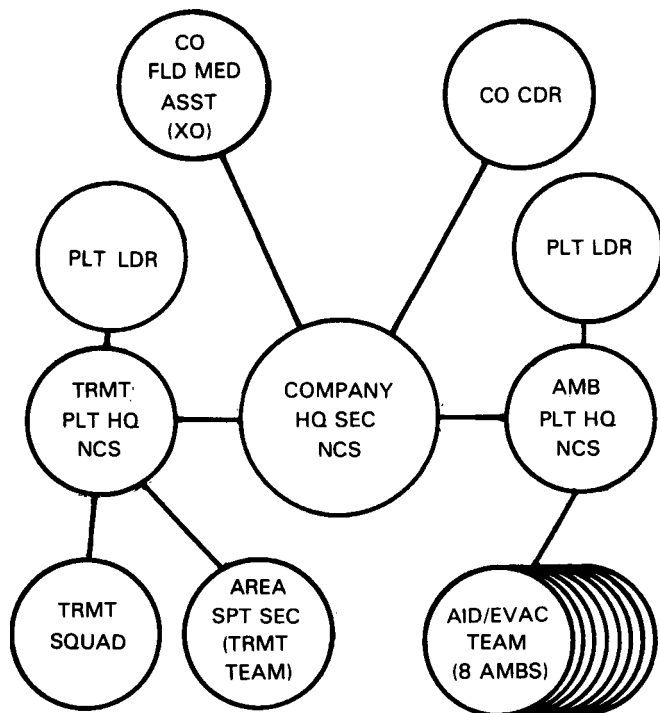

Figure 4-13. Forward support medical company tactical radio nets (FM).

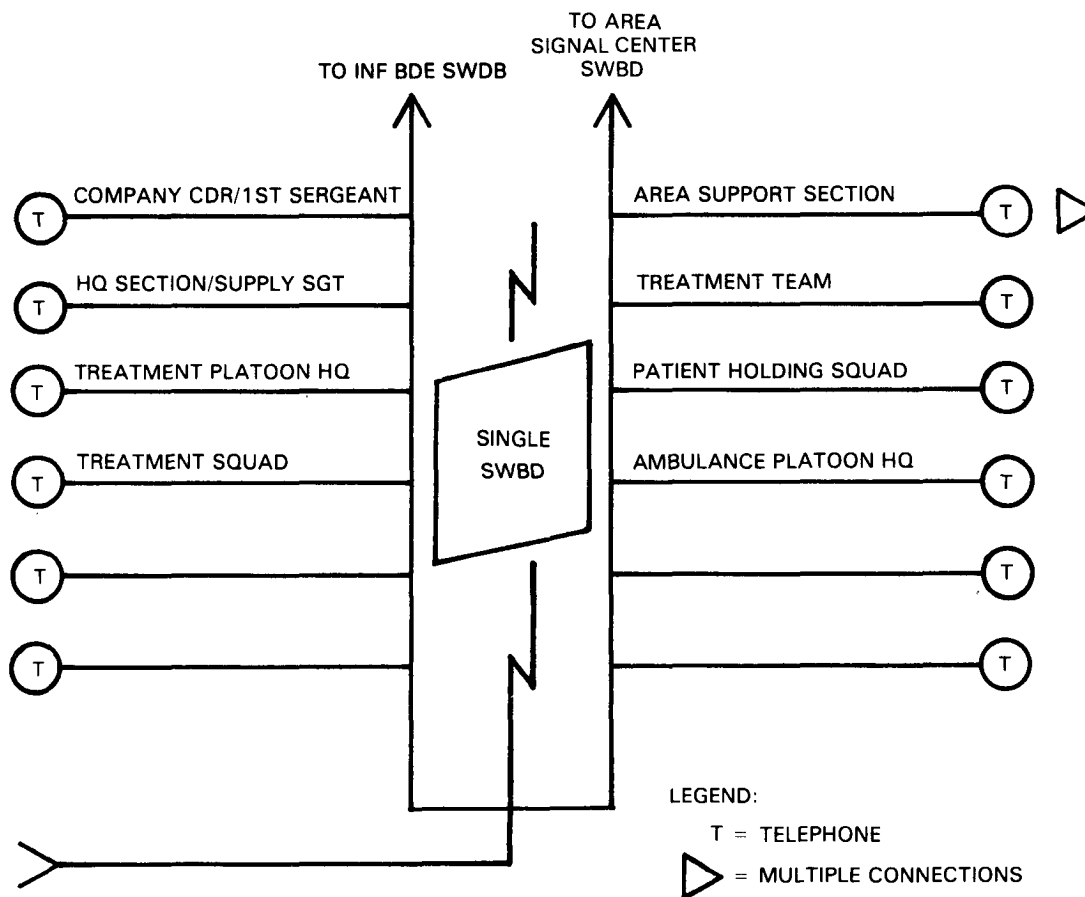

Figure 4-14. Forward support medical company wire net.

4-34. Battalion Headquarters Element Organization and Functions

a. The battalion headquarters is a major functional element organized under the HSC (Figure 4-15). For mutual administrative and logistical support, it is collocated with the support company element in the DSA (with division trains). The battalion headquarters is comprised of the following subelements:

- (1) Command Section.
- (2) S1 Section.
- (3) S2/S3 Section.
- (4) S4 Section and Division Medical Supply Office.

- (5) Preventive Medicine Section.
- (6) Optometry Section.
- (7) Mental Health Section.
- (8) Battalion Maintenance Section.

b. This headquarters provides C² for subordinate units; staff functions for the medical battalion; special staff functions for the division; and HSS for all divisional units. It provides administrative and logistical support for the battalion and plans for its employment. This headquarters provides C² or OPCON for attached nondivisional medical elements. Staff functions and relationships specified for battalion level organization in Chapter 4 of FM 101-5 are applicable to the medical battalion headquarters.

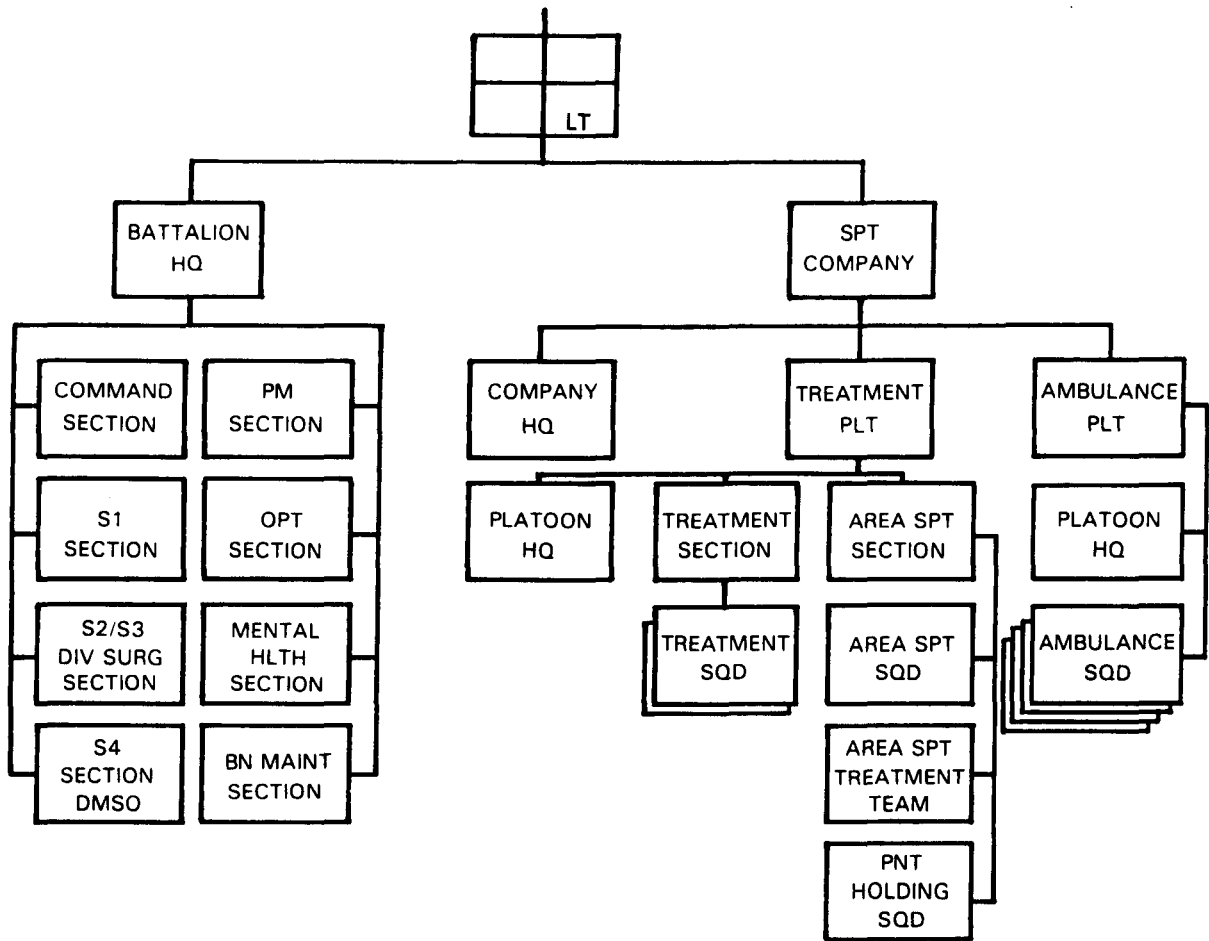

Figure 4-15. Headquarters and support company, medical battalion, light infantry division.

NOTE

To avoid degrading the battalion's support to organic units, provisions must be made for additional logistics support to attached nonmedical elements.

Command Section

- Bn Cdr*
- Bn XO
- Bn S1
- Bn S2/S3
- Bn S4
- CSM
- Vehicle Driver

*Also Division Surgeon

4-35. Command Section

The battalion command section (Figure 4-16) consists of the battalion commander and his immediate staff. These personnel supervise functions of the battalion headquarters elements.

Figure 4-16. Medical battalion command section.

a. *Battalion Commander.* The battalion commander plans, directs, and supervises battalion

activities; he prescribes policy, procedures, mission, and standards. His duties and responsibilities as the division surgeon are discussed in FM 8-10-5.

b. Battalion Executive Officer. The XO is the principal assistant to the battalion commander. He supervises and coordinates the functions of the battalion staff; and directs the rear battle defense program. The XO is also the battalion's materiel readiness officer.

c. Battalion S1. The S1 advises the commander on administrative and personnel matters. He develops and issues instructions for submission of records and reports. The S1 also authenticates and supervises the preparation and distribution of orders and instructions (other than operations orders).

d. Battalion S2/S3. The S2/S3 is the operations, intelligence, and training officer. This officer advises and assists the battalion commander in planning and coordinating battalion operations. He supervises planning, operations, security, NBC, intelligence, communications and training activities of the battalion. He also authenticates and supervises the preparation and distribution of operations orders.

e. Battalion S4. The S4 directs the logistical activities of the battalion; he advises and assists the battalion commander in logistic matters. He coordinates with the S3 in planning and implementing damage control measures. The duties and functions of the S4 are discussed in detail in FM 10-14-2.

f. Command Sergeant Major. The CSM is the battalion commander's principal enlisted assistant. He maintains liaison between the commander and first sergeants of subordinate units. The CSM advises and assists noncommissioned officers in accomplishing their assigned missions. He assists the commander in the inspection of subordinate units and other activities commensurate with his position.

4-36. Battalion S1 Section

The S1 section (Figure 4-17) assists the commander and staff in administrative and personnel matters.

The activities of this section includes the supervision of correspondence, personnel liaison, mail distribution, and dissemination of command information. The S1 section uses the battalion administration AM radio network and TACCS to communicate with FSMCs and corps-level HSS elements.

S1 Section

Battalion S1*
Personnel Staff NCO
P&A Specialist
Legal Clerk
Clerk Typist

*Located in Command Section

Figure 4-17. Typical battalion S1 section organization.

4-37. Battalion S2/S3 and Division Surgeon Section

The S2/S3/division surgeon section (Figure 4-18) performs two functions. It serves as the main operations planning element for the battalion; also as the staff HSS planning and operations element for the division. This section is responsible for—

- a. Formulating battalion plans.
- b. Publishing battalion operations order.
- c. Maintaining communications with and monitoring movement of battalion units.
- d. Providing rear area security and damage control for HSS elements.
- e. Training battalion units.
- f. Supervising and gathering medical intelligence.
- g. Planning for division-level HSS.

S2/S3 & Div Surg Section

Bn S2/S3 1/

Plans & Op Br

Fld Med Asst (Asst S2/S3)
 Bn Op Sgt
 Plans Sgt
 Intel & Scty Sgt
 NBC Staff NCO

Div Surg's Br

*Div PVNTMED Off 2/
 Div Den Surg 3/
 Div Psychiatrist 4/
 Div Hlth Svc Mat Off 5/
 Med Staff NCO
 Pt Admin Sp

Comm Br

Tactical Comm Ch
 Sr Radio Opr
 Cbt Signaler/SWBD Opr
 Single Chan Radio Opr
 Tac Comm Sys Opr/Mech

- 1 / Located in the command section
- * Serves as Asst Div Surg
- 2 / Located in preventive medicine section
- 3 / Located in Support Company's area support section
- 4 / Located in mental health section
- 5 / Located in S4/DMSO

Figure 4-18. Organization the battalion S2/S3 and division surgeon section.

4-38. Plans and Operations Branch

a. The plans and operations branch (Figure 4-18) of the battalion S2/S3 is responsible for—

- Planning and coordinating intelligence and security matters.
- Processing, interpreting, and disseminating information pertaining to the effects of METT-T and civilian population on the battalion's mission.
- Supervising the collection and disposition of medical intelligence,
- Disseminating technical intelligence.
- Developing plans, policies, programs, and procedures pertaining to the medical battalion's operations and functions.
- Planning, supervising, and inspecting the tactical and technical training of subordinate units.

- Planning and coordinating the augmentation or reconstitution of medical battalion units.
- Coordinating and providing current operational information to supporting corps HSS elements operating within the division.
- Planning, coordinating, and supervising the battalion's support of civil-military operations, psychological and unconventional warfare operations.
- Regulating (informal) patients within and out of the division.
- Planning and supervising defense against nuclear, biological, and chemical attack air defense; and unconventional and psychological warfare operations.
- Preparing the rear operations defense plan for the battalion headquarters and support company's immediate area of (base cluster). See FM 90-14.

- Advising the medical battalion commander and staff on all aspects of the activities discussed above.

NOTE

This branch supervises the execution of the rear operations defense plan under the direction of the battalion XO.

b. The field medical assistant (assistant S2/S3) in the battalion S2/S3 and the division surgeon's staff element coordinates all functions pertaining to health service plans, organization, operations, intelligence, and training.

4-39. Division Surgeon Branch

This branch focuses on the division surgeon's functions. It is assisted by the plans and operations branch and the battalion S1. The staff officers (Figure 4-12) who provide for the functions of the division surgeon's branch manage other major activities within the battalion. These officers (division PVNTMED officer, division dental surgeon, division psychiatrist, and health services materiel officer) may act for the surgeon in matters pertaining to their area of expertise. This branch acts independently of the S2/S3 and is responsible to the surgeon for—

- Preparing the HSS portion of the division staff estimate.
- Preparing the HSS annex to the division OPLAN, and preparing of the HSS annex to the division SOP.
- Coordinating and planning division-wide HSS.
- Preparing and coordinating MEDSOM/MEDLOG plans.
- Coordinating with division staff officers (and corps medical staff officers as required) on—

- Controlling critical HSS items of equipment and supplies.

- Preparing AMEDD personnel assignments; medical logistical support; medical records and reports; and augmentation and reconstitution of divisional HSS elements.

a. Division Preventive Medicine Officer. The division PVNTMED officer serves as the assistant division surgeon. He is located with the division PVNTMED section.

b. Division Dental Surgeon. The division dental surgeon serves as the special staff advisor to the division surgeon for all matters pertaining to dental support and planning. This officer also manages the area support squad of the support company he is located with that element. He provides emergency dental care and supervises other dental personnel in performing their duties.

c. Division Psychiatrist. The division psychiatrist is located with the division mental health section. His staff duties and responsibilities are discussed in FM 8-51.

d. Division Health Services Materiel Officer. The division HSMO has staff responsibility for planning and managing of medical materiel and supplies for the division. He is located with the S4 section/DMSO.

4-40. Communications Branch

a. Functions. The communications branch (Figure 4-18) develops, executes, and supervises the battalion signal communications SOP. This branch—

- Secures, maintains, and issues the command's Security Operations Instructions (SOI) booklet to battalion users.
- Implements the DISCOM signal communications SOP.
- Assures communications systems interface between the battalion and higher headquarters, and between the battalion and its subordinate units.

- Operates the battalion switchboard and control stations for the battalion's command/operations (FM voice) net and the administrative/logistical (AM voice) net.

- Provides for technical training to battalion users of communication-electronics (CE) equipment.

b. Tactical Communications Chief. The tactical communications chief serves as the signal advisor for the battalion. He is the principal advisor to the commander and the battalion S2/S3 in CE matters. The chief supervises the communication branch he advises on selecting a site for the battalion command post. He also works with the DISCOM communications officer to ensure integration of the battalion's communications systems.

4-41. Battalion S4 Section/Division Medical Supply Office

The S4 section and DMSO is comprised of two separate functional elements which are shown in Figure 4-19.

S4 SECTION/DMSO

Bn S4 Off*

S4 Element	Division Med Supply Ofc
Bn Supply Sgt Supply Sp	Hlth Svc Mat Off Med Supply Sgt Pharmacy NCO Med Eq Repairer, Advanced Med Eq Repairer Med Supply SP/Stock Issue Med Supply Sp/Stock Control

*Located in the command section

Figure 4-19. Typical S4 section/DMSO organization.

4-42. S4 Element

This office is responsible for planning, coordinating, and supervising unit-level general supply and services functions of the battalion. It is assisted by personnel in the DMSO. The S4 element also-

- Determines logistic requirements, maintains a property book, and provides general supply support to assigned and attached units of the battalion.
- Requisitions and issues general classes of supplies and equipment for units of the battalion.
- Assists in preparing plans for area damage control.

4-43. Division Medical Supply Office

This office is organized to provide Class VIII supply and unit-level medical equipment maintenance for the division. The functions of the DMSO include development and maintenance of prescribed loads of medical supplies; management of the medical quality control program and supervision of unit (organizational) medical maintenance support. This office also monitors the division medical assemblage management program and coordinates LOG PLAN requirements for preconfigured Class VIII packages.

4-44. Medical Supply Operations

a. Medical supplies, equipment, and repair parts are provided through medical logistics channels. The HSMO manages Class VIII supplies and equipment to include medical maintenance and repair services for the division.

b. Two days of medical supplies are stocked by unit- and division-level medical treatment elements. Five days of medical supplies are maintained by the DMSO. During the initial deployment phase, each FSMC will receive a medical resupply preconfigured PUSH package every 48 hours until elements of the corps MEDSOM/MEDLOG battalion are established.

c. During deployment, lodgment, and early buildup phases, medical units will operate from planned prescribed loads and from existing prepositioned war reserve stockpiles identified in LOGPLANS. Also, as defined in LOGPLANS, initial resupply efforts may consist of preconfigured medical supply packages tailored to meet specific mission requirements. Resupply by preconfigured packages will be direct to the division until replenishment line item requisitioning is established with the supporting MEDSOM/MEDLOG battalion. Resupply by preconfigured packages is intended to provide support during the initial phase; continuation on an exception basis may be dictated

by operational needs. Planning must be coordinated with the supporting MEDSOM/MEDLOG battalion.

d. Requests for medical materiel flow from divisional supported elements to the DMSO (Figure 4-20). The DMSO issues from stock on hand or forwards the requisition to the corps MEDSOM/MEDLOG battalion, using the division TACCS as required. Shipment of medical material from the DSA to users in the forward area is by the backhaul method or coordinated with the movement control office (MCO).

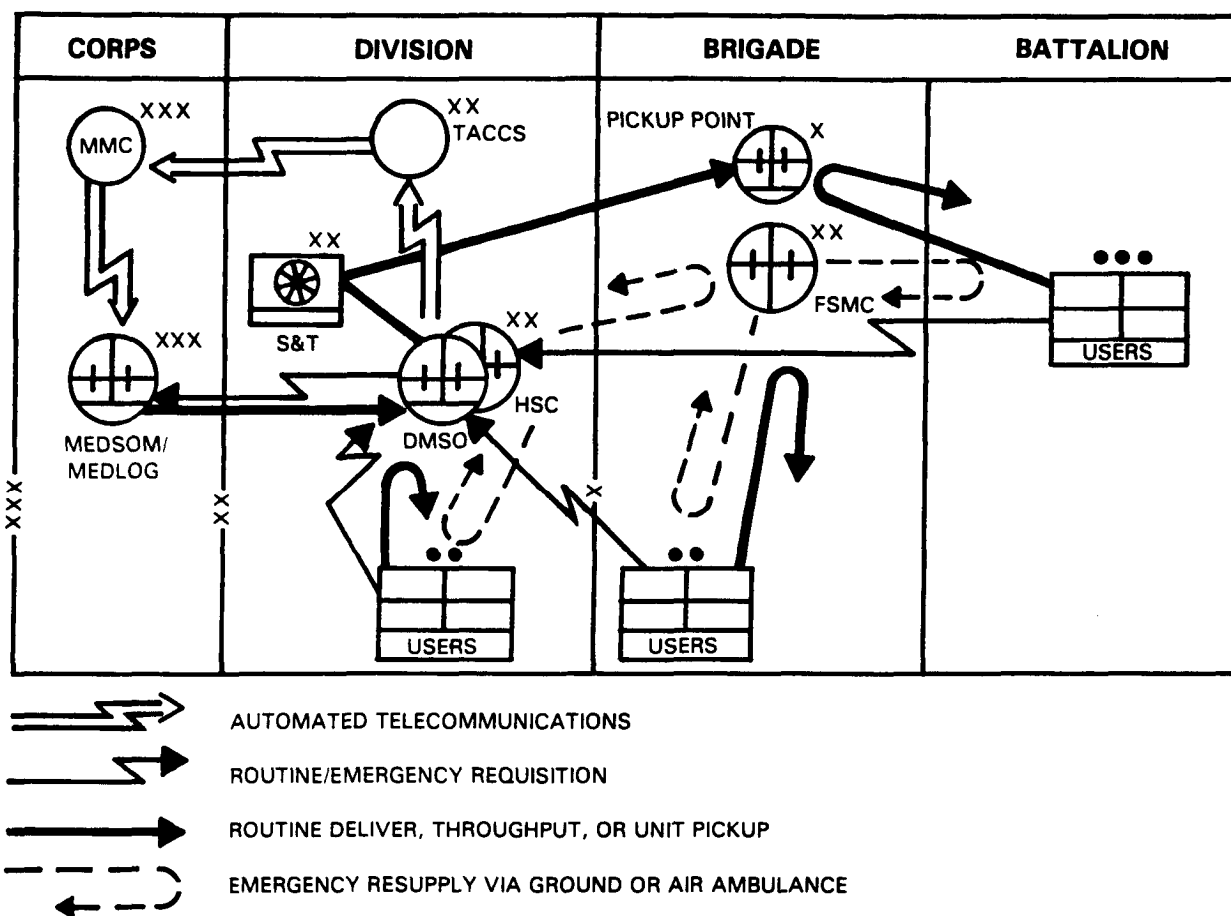

Figure 4-20. Requisition and flow of Class VIII supplies within the combat zone.

4-45. Battalion Maintenance Section

a. The battalion maintenance section (Figure 4-21) is under the staff supervision of the battalion S4. It is organized into three functional work areas:

- A management element.
- A motor vehicle repair shop.
- A power generator repair shop.

b. This section establishes the battalion motor pool and provides unit-level (organizational) maintenance and repair services for all the medical companies of the battalion. For unit maintenance operations, see FM 43-5.

BN MAINTENANCE SECTION

Section HQ	Motor Veh Repair Shop
-------------------	------------------------------

Bn Mtr Off Bn Maint Sgt Shop Clerk PLL Clerk	Sr Mtr Veh Mech (3) LtWVeh Mech (8)
---	--

Power Generator Repair Shop**

Sr Pwr Gen Rep
 Pwr Gen Eq Rep (3)

*2-contact team capability
 **1-contact team capability

Figure 4-21. Typical maintenance section organization.

c. The battalion motor officer plans, directs, and supervises activities of the battalion maintenance section (less medical maintenance). He also—

- Keeps the battalion commander and staff informed of the maintenance situation and the operational status of equipment.
- Analyzes the maintenance situation.
- Plans and evaluates maintenance programs.
- Coordinates maintenance operations with direct support units and other units as required.
- Monitors calibration requirements and arranges for calibration support.
- Keeps the battalion materiel readiness officer informed of the operational readiness status of vehicles and power generation equipment.

- Monitors PLL operations and the Army Oil Analysis Program.

- Supervises the use of maintenance services and the training and licensing of vehicle drivers and equipment operators.

- Directs and coordinates organizational maintenance throughout the battalion.

In coordination with the Bn S3:

- Implements training and safety programs for operators and supervisors of battalion vehicles and power generating equipment.

- Inspects battalion units to ensure equipment maintenance standards; and to ensure maximum use of equipment and vehicle assets.

- Trains subordinates.

4-46. Division Preventive Medicine Section

a. *Responsibilities.* The PVNTMED section is responsible for supervising the command PVNTMED program (see AR 40-5). This section assists in training unit field sanitation teams. The PVNTMED section is staffed as shown in Figure 4-22. Its specific functions include, but are not limited to—

- Assisting the surgeon in preparing the staff estimate by identifying the medical threat.

- Assisting the Bn S2/S3 in determining requirements for medical intelligence collection, particularly disease prevalence.

- Conducting surveillance of divisional units to—

- Ensure use of PVNTMED measures at all levels.

- Identify health threats and recommend corrective action as required.

- Assisting divisional units in training PVNTMED measures against heat and cold injury, and food-, water-, and arthropod-borne diseases.

- Monitoring the immunization program.
- Monitoring the health aspects of water production, distribution and consumption.
- Monitoring disease and injury incidence to optimize early recognition of disease trends and recommending preemptive disease suppression measures.
- Conducting epidemiological investigations of disease outbreaks and recommending PVNTMED measures to minimize effect.
- Monitoring division level resupply of disease preventive supplies and equipment, including water disinfectants, pest repellents and pesticides.
- Conducting limited entomological investigations and control measures.
- Monitoring environmental/meteorological conditions; assessing their health related impact on division operations; and recommending PVNTMED measures to minimize their effects.
- Deploying PVNTMED teams in support of specific units/operations as required.
- Assisting in identification/evaluation of NBC contamination in water supplies.

**Division PVNTMED
Section**

Div PVNTMED OFF
Env Science Off
PVNTMED NCO
PVNTMED Specialists (6)

Figure 4-22. Personnel staffing of a division preventive medicine section.

b. Division Preventive Medicine Officer. The division PVNTMED officer is responsible for the division's PVNTMED program. Based on

command guidance and division requirements, he plans, directs and prioritizes the PVNTMED section's activities; serves as the principal advisor on medical threats that will be encountered by divisional units; and recommends PVNTMED measures to minimize these threats.

c. Environmental Science Officer. The environmental science officer assists the division PVNTMED officer in developing, implementing, and supervising the division PVNTMED program. He assesses potential health threats and recommends PVNTMED measures. This officer provides consultation to commanders concerning environmental sanitation advises on public health policy affecting the health of the command; and advises on public health matters during civil affairs operations, when required. He also supervises PVNTMED specialists monitoring the division's PVNTMED program to identify potential or actual health hazards.

4-47. Concept for Preventive Medicine Support

a. Basis for Preventive Medicine Support. History teaches that in past conflicts more soldiers have been noneffective due to DNBI than to battle injuries. Often the victor in battle has been the force with the healthiest troops. Consequently, PVNTMED operations are based on preemptive action; increased soldier and commander involvement; and priority to combat units. To accomplish this the PVNTMED section is deployed as teams to support, specific units/operations (for example, deployed in direct support of a brigade or battalion task force) as required. The teams will be organized based on the medical threat.

b. Predeployment Action. Before deployment much can be done to minimize DNBI. Actions include ensuring command awareness of potential medical threats and implementing PVNTMED measures; monitoring immunization status of personnel; and monitoring individual and unit's awareness of heat or cold injury, and food-, water-, and arthropod-borne diseases. Immediate effectiveness of PVNTMED measures will depend on the early arrival of PVNTMED personnel. During the initial deployment phase, PVNTMED personnel are inserted to preemptively reduce the medical threat to deploying forces; they assess its effect on follow-on forces. It is anticipated—

- That sanitation breakdowns will occur while troops are in debarkation assembly areas.

- That disease vectoring will begin as soon as forces enter the area of operations.

NOTE

To avoid health and environmental problems historically encountered by deploying troops, it is imperative that divisional preventive medicine assets be deployed in advance of the main body/forces.

c. Preemptive Action. Preventive medicine operations are characterized by preemptive action. Preventive medicine cannot wait until troops are incapacitated to take action. They must initiate action on presumptive information to reduce the medical threat. For example, mosquito populations near troop assembly areas must be suppressed without waiting for confirmation that they carry diseases; sandflies in towns along routes of march must be suppressed without waiting for the incubation of sandfly fever; and inadequate sanitation practices must be brought to the attention of responsible commanders before the first case of dysentery appears. Lack of, or delay in preemptive actions can significantly impact on the deploying force's ability to accomplish its assigned mission.

4-48. Division Optometry Section

a. Functions. The division optometry section (Figure 4-23) provides limited optometry services, including routine eye examination and refraction; spectacle assembly using presurfaced single-vision lenses; and spectacle repair services for units organic or attached to the division.

b. Division Optometry Officer. The division optometrist performs eye examinations and treats vision disorders within his capabilities. He refers pathological vision deficiency cases to Echelon III

physicians as required; he plans and directs the activities of the optometry section; and provides clinical statistical input to the division surgeon.

Div Optometry Section

Optometry OFF
Optical Lab Sp
Eye Sp

Figure 4-23. Typical division optometry section organization.

4-49. Division Mental Health Section

a. The division mental health section (DMHS) is responsible for assisting the command in controlling combat stress through prevention programs; maximizing the RTD rate with far forward care of battle fatigue casualties; and providing division-wide mental health services. The DMHS is collocated with the DCS in the DSA. When the division is garrison-based, it also assists in coordinating social support services for division personnel and their families. Functions of the DMHS include—

(1) Providing education programs and individual case consultation to unit leaders and medical personnel on prevention, early recognition and intervention for battle fatigue (also stress fatigue in noncombat situations), substance abuse, suicidal risk, and neuropsychiatric and personality disorders.

(2) Providing technical supervision—

- For unit preventive psychiatry (combat mental witness) plans and SOPs.

- For restoration to effectiveness of moderate battle fatigue casualties.

- For the treatment and RTD of severe battle fatigue casualties.

(3) Providing direct clinical services (specialized differential diagnosis, evaluation, limited treatment and referral/disposition) to soldiers with neuropsychiatric disorders and to problematic battle fatigue cases.

(4) Maintaining contact with supported units; provides staff planning to predict battle fatigue casualties; coordinates corps mental health assets placed in direct support to treat battle-tired casualties; and assist in the rest and recuperation of battle fatigued units.

(5) Planning for and coordinating a corps-level Mental Health Program for providing up to 2 weeks observation and reconditioning therapy. This program is established in the corps support area to hold battle fatigue/neuropsychiatric patients for 14-days with the potential of returning them to the division. Patients entering this program are not counted as hospital admissions (not affected by the theater evacuation policy) until after the 14-day holding period.

(6) When the division is garrison-based, coordinating with unit commanders; supporting medical department activity (MEDDAC) social support services; and other social support services to assist soldiers in minimizing home-front stresses.

(7) Developing and conducting a comprehensive combat mental fitness program which—

- Monitors division units for low morale, AWOL, disciplinary problems, and other unhealthy factors.

- Uses intervention techniques that involve unit commanders, staff chaplains, and others in correcting unit-centered problems.

- Assists commanders to improve organizational climate and effectiveness during changes of command; unit rest and recuperation; personnel deployment/rotation between CONUS/OCONUS; and other high stress situations.

b. The division mental health section is staffed as shown in Figure 4-24. The consolidation of assigned mental health officers in the DCS emphasizes the division-wide preventive, education and treatment responsibilities of the section.

c. The division psychiatrist directs the division's mental health program. This officer is a working physician. His specific functions include—

- Establishing and operating the DMHS.

- Consulting on matters having psychiatric components. These include nuclear surety, security clearances, child and spouse abuse programs, and alcohol and drug abuse programs.

- Diagnosing, treating, rehabilitating, and disposition of neuropsychiatric and battle fatigue patients.

- Participating in the diagnosis and treatment of the wounded, ill and injured, especially those who can RTD.

NOTE

General medical duties (treatment of wounded, ill and injured) must not distract the psychiatrist from his primary neuropsychiatric duties.

- Training and consultation for unit leaders and medical personnel on identification and management of neuropsychiatric disorders.

- Providing therapy or referral for soldiers with psychiatric problems.

- Supervising and training assigned and attached mental health personnel.

Division Mental Health Section

Division Psychiatrist
 Division Psychologist
 Division Social Work Officer
 Senior Behavioral Science NCO
 Behavioral Science NCO (3)
 Behavioral Science Specialist/Driver (3)

Figure 4-24. Staffing of the division mental health section.

d. The psychologist assists in the division's mental health program, especially applying the knowledge and principles of psychology to—

- Evaluating and assuring the RTD of battle fatigued soldiers.

- Conducting surveys and evaluating data to assess unit cohesion and other factors on predicting and preventing battle fatigue casualties.

- Performing neuropsychological testing to evaluate psychological problems, psychiatric and neurological disorders, and to screen unsuitable soldiers.

- Apprising unit leaders, primary care physicians, and other clinical personnel on the assessment of individual and unit mental fitness.

- Providing consultation for unit commanders and combat stress control coordinators (mental health NCOs working at brigade level) on problem cases.

- Counseling and providing therapy or referring soldiers with psychological problems.

e. The social work officer assists in the division's mental health program, especially applying the knowledge and principles of social work to—

- Evaluating battle fatigued soldiers.

- Coordinating and assuring the return of battle fatigued soldiers to duty.

- Identifying and resolving organizational and social environmental factors which interfere with combat readiness.

- Assuring support for division soldiers and their families from Army and civilian community support agencies.

- Apprising unit leaders, primary care physicians, and other clinical personnel of available social service resources.

- Providing consultation to unit commanders and to DMHS combat stress control coordinators on problem cases.

- Counseling and providing therapy or referring soldiers with psychological problems, including spouse and child abuse.

4-50. Overview of Mental Health Support

The overall effectiveness of the combat mental fitness program depends on the assignment and distribution of mental health personnel. It is essential that the medical commander promote training, including field experience and cross-training of critical clinical skills. To fill their roles, mental health personnel must be familiar with the units they support; and be known by unit leaders and organic medical personnel. This can only be achieved by intensive involvement in garrison and field training. The primary preventive role of the DMHS involves a continuum of services along the spectrum of conflict, from peacetime through low intensity to high intensity conflicts. This entire continuum must therefore be included in the DMHS's focus, training, and method of operation.

a. When the division is in garrison, the DMHS operates a Mental Health Clinic. The division psychiatrist, assisted by the psychologist, social work officer, and behavioral science specialists staff the division's mental health clinic.

b. During tactical operations, DMHS officers assure a 24-hour diagnostic and evaluation capability at the DCS located in the DSA. All patients who are evacuated because of behavioral (functional) or mental symptoms are routed to the nearest DCS.

c. For detailed information on combat stress control, battle fatigue/neuropsychiatric cases, and combat stress control organizations and functions, see FM 8-51.

Section V. SUPPORT COMPANY ELEMENT

4-51. Organization and Functions

a. The support company and battalion headquarters elements are organized under the medical battalion HSC. The HSC is dependent upon—

(1) Elements of the division for religious, legal, personnel and administrative services; clothing exchange and bath services; graves registration; support for securing and handling enemy prisoner of war (EPW) patients; security during tactical moves; and area damage control support.

(2) Elements of corps for finance, laundry, personnel and administrative support.

(3) Corps assets for air and ground evacuation of patients to corps level treatment facilities.

(4) The DISCOM headquarters and Headquarters Company for food service support.

b. The support company is similar in design to the three forward support medical companies. Its major functional components (Figure 4-14) include a company headquarters, a treatment platoon, and an ambulance platoon. The company provides unit- and division-level HSS in the DSA. It has capabilities to—

- Perform triage, initial resuscitation, stabilization, and preparation of sick, wounded, or injured patients for evacuation.

- Provide outpatient consultation services for patients referred from unit-level medical treatment facilities.

- Perform emergency dental care and limited preventive dentistry.

- Provide basic diagnostic laboratory and radiology services and patient holding.

- Provide backup support for the forward support medical companies.

- Provide ground ambulance evacuation (for patients selected to be held in the DSA and returned to duty within 72 hours) from medical companies operating in the BSAs. The company also provides ground evacuation from unit-level medical treatment facilities and nonmedical units operating in the DSA.

- Provide limited emergency medical resupply to divisional unit-level medical elements operating in the DSA.

4-52. Company Headquarters

The company headquarters provides C², billeting discipline, security, training, and administration for assigned personnel. The headquarters element of the support company must collocate with the battalion headquarters; therefore, it is austere staffed. Technical NBC assistance and organizational maintenance support for the company's vehicles, CE and power generation equipment is provided by elements of the battalion headquarters. The company headquarters is staffed as shown in Figure 4-25. For communications, the company headquarters employs an FM tactical radio and is deployed in the battalion command/operations net (Figure 4-9). The support company's wire and radio communications nets are shown in Figure 4-13 and Figure 4-14 respectively. This element also—

- Plans, directs, and supervises unit training and security for its platoons.

- Provides general supply support and company level administration for all elements of the HSC.

- Plans and supervises rear area operations as directed by the battalion commander.

a. *Company Commander.* The company commander plans, directs, and supervises the operations and employment of the company. He is responsible for training, discipline, billeting, security, welfare, and tactical employment of the headquarters and support company. The commander is also a working physician in the DCS.

b. Field Medical Assistant. The field medical assistant serves as the company XO. He is the principal assistant to the commander in all matters pertaining to the tactical employment of the company. This officer supervises and coordinates the security, plans, tactical operations, communications, OPSEC, logistics, and training functions of the company.

c. First Sergeant. The first sergeant is the principal enlisted assistant to the commander. This senior NCO manages the administrative activities of the command post; supervises the activities of the supply sergeant and unit clerk maintains liaison between the commander and assigned NCOs; and provides guidance to enlisted members of the company, and represents them to the commander.

Company Headquarters

(Command Element)	(Supply Element)
Co Cdr	Unit Supply Sgt
Fld Med Asst/XO	Armorer/Driver
1st Sg	
Unit Clerk/Swb Op	

Figure 4-25. Support company headquarters organization.

4-53. Treatment Platoon

The treatment platoon operates the DCS. It receives, triages, treats, and dispositions patients based upon their medical condition. This platoon also provides professional services in the areas of minor surgery, internal medicine, general medicine, and general dentistry. In addition, it provides basic diagnostic laboratory and radiology services and patient holding. The treatment platoon (Figure 4-26) is composed of a platoon headquarters, an area support section, and a treatment section. The platoon is normally collocated with the division optometry and mental health sections. For communications, the platoon employs six tactical radios; operates the company's net control station; and is deployed in the HSC wire communications net.

4-54. Treatment Platoon Headquarters

This office is the C² element for the platoon. It determines and directs the disposition of patients received from the FSMCs and other supported units; it coordinates their evacuation. For communication this element employs an FM tactical radio mounted in its assigned vehicle.

a. Platoon Leader. The platoon leader directs, coordinates, and supervises platoon operations and assumes command of the company when the commander is absent. This officer is also the physician on the area support treatment team; he directs the activities of the DCS.

b. Field Medical Assistant. The field medical assistant is the platoon operations officer. He is the primary assistant to the platoon leader for the platoon operations; OPSEC; communications; administration; organizational training supply; transportation and patient regulating/evacuation.

4-55. Area Support Section

The area support section forms the DCS. It is composed of an area support treatment team, an area support squad, and a patient holding squad. These elements operate as a single treatment unit; they provide both unit- and division-level medical support for units operating in the DSA and serve as the primary MTF for patients that overflow BSA clearing stations. Elements of this section are not used to reinforce or reconstitute forward supporting medical units. Normally, they are not used on area damage control teams.

4-56. Area Support Treatment Team

a. The area support treatment team is the base medical treatment element of the DCS. It provides troop clinic type services and ATM. This team, in coordination with the DMSO, may also provide limited emergency medical resupply of supported medical units operating in the DSA. For communications, the team employs an FM tactical radio, operates the company/treatment platoon net control station, and monitors the battalion command net. The personnel staffing of this team is shown in Figure 4-26.

TREATMENT PLATOON**PLATOON HQ**

Plt Ldr
 Fld Med Asst
 Plt Sgt
 Pat Admin Sp/Rad Opr/Driver

TREATMENT SECTION**TREATMENT SQD (1st Sqd)**

Op Med Off	"A"
Physicians' Asst	"B"
EMT NCO	"A"
EMT NCO	"B"
Med Sgt	"B"
Med Sp	"A"
Med Sp/Rad Opr/Drv	"A"
Med Sp/Rad Opr/Drv	"B"

TREATMENT SQD (2d Sqd)

Op Med Off	"A"
Physicians' Asst	"B"
EMT NCO	"A"
EMT NCO	"B"
Med Sgt	"B"
Med Sp	"A"
Med Sp/Rad Opr/Drv	"A"
Med Sp/Rad Opr/Drv	"B"

"A" — ALFA Team
 "B" — BRAVO Team

AREA SUPPORT SECTION**AREA SPT TMT TM**

Op Med Off
 EMT NCO
 Med Sp
 Med Sp/Rad Opr/Drv

AREA SUPPORT SQUAD

Den Off
 Den Sp
 Med Lab Sp
 X-ray Sp

PATIENT HOLDING SQD

Wardmaster
 Practical Nurse
 Med Sp, Nrs Asst/PwrG Op
 and 5-ton Trk Drv
 Med Sp, Nrs Asst/PwrG Op
 and 5-ton Trk Drv

Figure 4-26. Organization and staffing of a support (medical) company treatment platoon.

b. The primary care physician is also the treatment platoon leader. He examines, diagnoses, treats, and prescribes courses of treatment for patients. He also directs the activities of the DCS.

4-57. Area Support Squad

a. This squad comprises the dental and diagnostic support elements of the DCS. The dental

element provides emergency dental care to include treatment of minor maxillofacial injuries; limited preventive dentistry; and dental consultation services. The diagnostic element provides basic diagnostic laboratory and radiology services. Medical laboratory specialists in both the HSC and FSMC perform laboratory tests in direct support of ATM activities. To augment area medical support efforts within the division these specialists have the capability to collect diagnostic specimens and ship

Paragraph 4-61 implements STANAG 2061.

them to higher echelon medical laboratories for analyses. Test results may be transmitted to requesting MTFs via available computer systems [TACCS and others].

b. The dental officer (the division dental surgeon) examines, diagnoses, treats, and prescribes treatment for diseases, abnormalities, and defects of teeth and their supporting structure. As the division dental surgeon, he serves as a special staff officer to the division surgeon, he advises/oversees all dental matters, to include monitoring the state of oral health fitness within the division. He exercises technical control of division dental assets with respect to—

- Quality assurance.
- Divisional Oral Health

Program.

- The dental provisions 600-8-101 (Personnel Processing).
- Treatment priorities augmentation or reconstitution of division dental assets is required.

He coordinates support from corps area support dental units through the DMOC or the S2/S3 section of the medical battalion headquarters. This officer also performs ATM procedures and supervises the activities of the area support squad.

4-58. Patient Holding Squad

The patient holding squad operates the patient holding facility of the DCS. The primary function of this 20-patient capacity activity is to provide nursing care for those patients admitted for minor injuries or illnesses (to include battle fatigue and neuropsychiatric patients) that are expected to be returned to duty within 72 hours. This facility is under the direct supervision of the DCS physician. Patients are admitted to the patient holding facility on an outpatient basis and are not counted as hospital admissions.

4-59. Treatment Section

a. The treatment section (refer to Figure 4-26) is composed of two treatment squads,

designated “first” and “second” squad. These squads perform routine medical care, triage, and ATM. They are expansion elements of the DCS. The HSC treatment squads are identical to those of the FSMC and the combat battalion’s (squadron’s) medical platoon. These squads may be employed to reinforce or reconstitute other divisional medical elements. They may also be employed in direct support of rear area task force operations, including area damage control and mass casualty operations. Each squad has the capability to operate as two treatment teams (ALFA and BRAVO teams) for a limited period of time. Staffing for the treatment teams is shown in Figure 4-26.

b. The primary care physician plans and supervises the activities of the treatment squad examines, treats, and prescribes courses of treatment in the routine care of patients; provides ATM care for seriously injured/wounded and serves as the task force surgeon when required.

4-60. Treatment Squad Operation and Employment

Each treatment squad employs two HMMWV treatment vehicles with four medical equipment sets (MES); two trauma sets and two general sick call sets (one of each type per treatment team). The squads normally locate with the DCS and operate in tandem with the area support section. When the DCS displaces, one squad serves as the jump element and moves forward (or rearward) to establish the DCS at the new location. In support of rear operations or other special operations, one squad may be employed as a direct support element. These squads may also operate as two treatment teams and may be used to reinforce forward support medical companies. For communications, each treatment team employs one FM tactical radio mounted in its assigned vehicle.

4-61. Division Clearing Station

Division clearing station is the generic term used in designating the division level MTF in both the BSA and DSA (STANAG 2061). This medical treatment facility is operated by the medical company’s treatment platoon. In the DSA it is collocated with the division mental health and optometry sections.

The DCS provides both unit- and division-level medical support to all divisional and nondivisional units operating in the division support area. The DSA clearing station also serves as the backup for the BSA DCS. While the DSA clearing station normally receives patients from units located in the DSA, it may become necessary for the Med Bn

S2/S3 to regulate patients directly from BASs to this MTF. Since the DSA clearing station is less likely to displace as frequently as a DCS in the BSAs, it is ideally suited to be augmented with a surgical capability. A suggested layout of a DCS with surgical squad capability is shown in Figure 4-27.

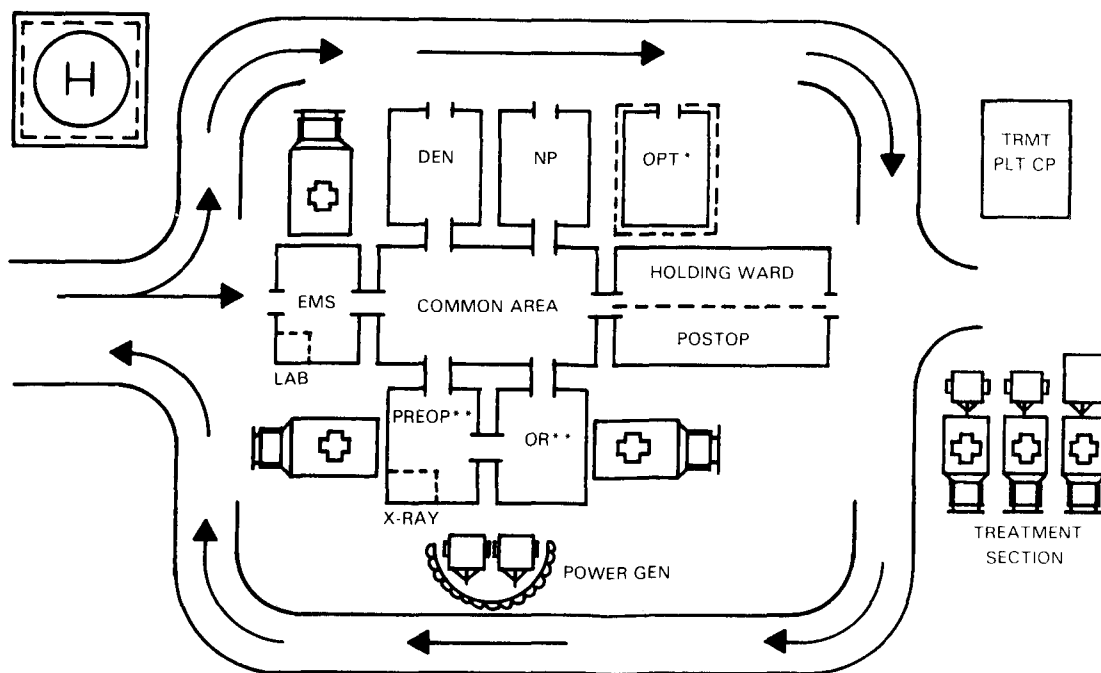

- DEN DENTAL CARE AREA
- EMS EMERGENCY MEDICAL SERVICE AREA
- HMMWV HIGH MOBILITY MULTI-PURPOSE WHEELED VEHICLE WITH TREATMENT SHELTER
- LAB MEDICAL LABORATORY AREA
- NP NEUROPSYCHIATRIC SERVICE AREA
- OPT OPTOMETRY SERVICE AREA
- OR OPERATING ROOM AREA
- PREOP PREOPERATIVE CARE AREA
- POSTOP POSTOPERATIVE CARE AREA
- TRMT PLT CP TREATMENT PLATOON COMMAND POST
- X RAY X RAY AREA

* LOCATED IN THE HEADQUARTERS AND SUPPORT COMPANY'S CLEARING STATION ONLY.
 ** AUGMENTATION (INCLUDES PERSONNEL AND EQUIPMENT).

Figure 4-27. Suggested layout of a division clearing station.

4-62. Ambulance Platoon

a. The ambulance platoon (Figure 4-28) performs ground evacuation and en route patient care for supported units in the DSA. It also evacuates patients from the BSA DCSs to the DSA DCS. This platoon may also reinforce ambulance platoons of FSMCs. The HSC ambulance platoon is identical to the FSMC ambulance platoon in TOE.

It is staffed with a platoon leader, a platoon sergeant, two aid/evacuation sergeants, six aid/evacuation specialists, and eight medical specialists/ambulance drivers. The ambulance platoon comprises a platoon headquarters, four ambulance squads (or eight ambulance teams), one HMMWV control vehicle, and eight HMMWV ambulances.

b. The platoon leader leads and plans for the employment of the platoon. He establishes and maintains contact with supported FSMCs; makes

route reconnaissances, develops and issues strip maps; and establishes AXPs for both ground and air ambulances as required.

AMBULANCE PLATOON

		Platoon Headquarters	
		Plt Ldr	*2 Ambulance Teams
		Plt Sgt	**Supervises 2 Ambulance Squads
Amb Sqd (1st Sqd)*	Amb Sqd (2d Sqd)*	Amb Sqd (3d Sqd)*	Amb Sqd 4th Sqd)*
Sr Aid/Evac NCO**	Aid/Evac Sp	Sr Aid/Evac NCO**	Aid/Evac Sp
Aid/Evac Sp	Med Sp/Amb Drv	Aid/Evac Sp	Med Sp/Amb Drv
Med Sp/Amb Drv		Med Sp/Amb Drv	

Figure 4-28. Organization and staffing of an HSC ambulance platoon.

4-63. Ambulance Platoon Operations and Employment

The ambulance platoon headquarters normally collocates with the treatment platoon headquarters to maximize evacuation support coordination. All ambulance platoon assets may be deployed at one time. The platoon normally places one ambulance team in direct support of each FSMC and places two teams in support of units in the DSA. The

remaining three teams are used for task force operations, backup support, or ambulance shuttle. Each ambulance carries an MES configured for en route patient care. For communications, the ambulance platoon employs nine vehicular mounted FM tactical radios and deploys in the HSC wire communications net. The platoon operates its own net control station and monitors the support company's operations nets. The HSC ambulance platoon's area of operations is shown in Figure 4-29.

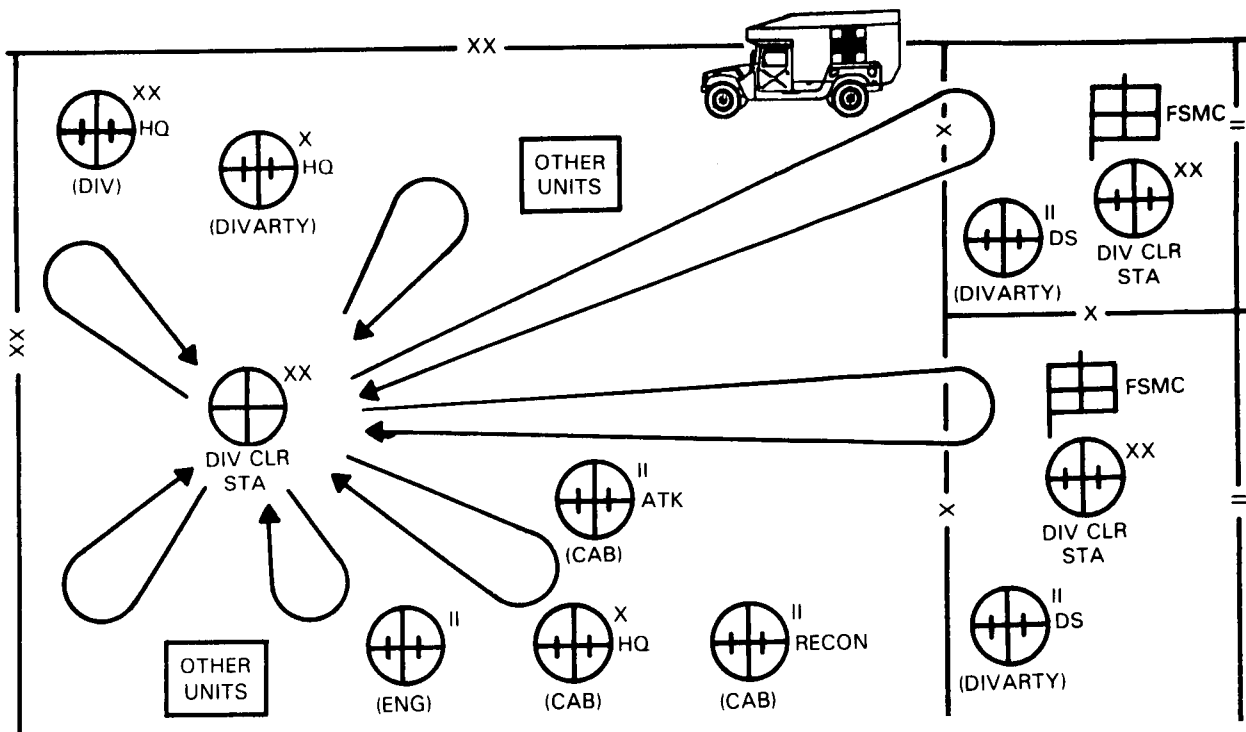

Figure 4-29. HSC ambulance platoon area of operations.

Section VI. FORWARD SUPPORT MEDICAL COMPANY

4-84. Organization and Functions

a. The FSMC has the overall mission to provide division-level HSS to all units operating in a

BSA; also unit-level HSS to units without organic HSS. It is organized into a company headquarters, a treatment platoon, and an ambulance platoon (Figure 4-30).

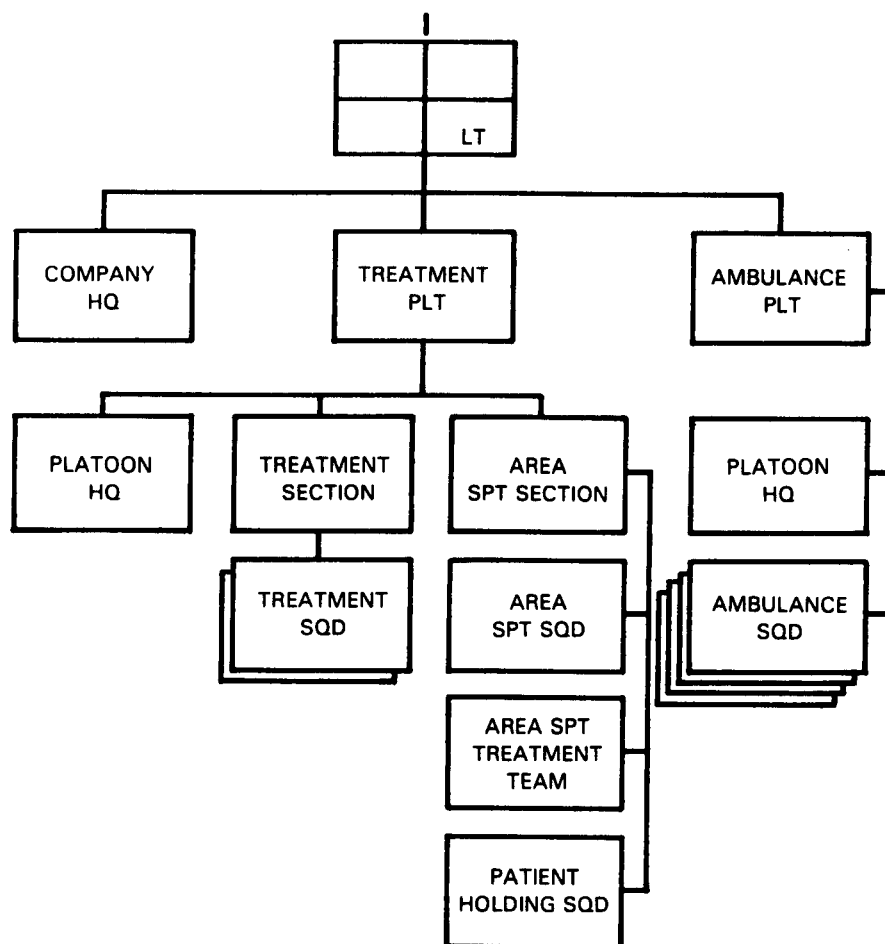

Figure 4-30. Forward support medical company, medical battalion, light infantry division.

b. The FSMC provides—

- Treatment for patients with minor diseases, triage, initial resuscitation/stabilization, ATM, and preparation for RTD or further evacuation.

- Ground evacuation for patients from BASS.

- Emergency dental care.

- Emergency medical resupply to units operating in the BSA.

- Medical laboratory and radiology services commensurate with division level treatment.

- Outpatient consultation services for patients referred from unit-level MTFs.

- Patient holding for up to 20 patients expected to RTD within 72 hours.

4-65. Operations and Employment

a. The FSMC is organic to the medical battalion and is a DISCOM asset. It is dependent upon the supported brigade for local security and tactical movement. The company is also dependent upon the DISCOM supply and transportation (S&T) battalion for food service support. The FSMC usually deploys with its DCS in the BSA; however, the organic treatment squads have the capability of operating independently of the medical company for a limited period of time.

b. Medical support requests including aeromedical evacuation, ground ambulance, emergency medical resupply, and reinforcement support are normally transmitted through the brigade to the supporting FSMC; however, such requests may be transmitted directly to the FSMC. Ambulances from the ambulance platoon evacuate patients from BASS and transport them to the FSMC clearing station. More seriously injured patients are evacuated by supporting corps air ambulances. Patients treated by the FSMC may either be RTD, held for 72 hours, or evacuated to a corps hospital. The FSMC has a holding capability of 20 patients. Minimally ill or injured patients that overflow (exceed the capacity of the holding facility) the BSA clearing station may be evacuated to the DSA clearing station by HSC ambulances. Patient evacuation from the BSA clearing station to combat zone hospitals is performed by corps ground and air ambulances.

c. Request for patient evacuation from the FSMC to corps MTFs are transmitted directly to the supporting corps air or ground evacuation unit. These requests are monitored by the medical battalion S2/S3 staff; they may intervene when necessary or upon request.

d. Two days of Class VIII supplies are stocked by all FSMC treatment elements. During the initial deployment phase the FSMC will receive a medical supply PUSH package every 48 hours. Once the corps MEDSOM/MEDLOG battalion is established, Class VIII supplies will be requested and filled by standard line item requisition.

e. Medical maintenance support is provided by the supply element of the FSMC headquarters.

Backup support is provided by the medical battalion DMSO.

f. The FSMC provides a liaison representative (normally a field medical assistant) to the maneuver brigade's S2/S3 office to coordinate HSS requirements for the brigade and to stay abreast of the combat situation.

NOTE

Division and corps medical support elements (except air and ground ambulance elements) placed in direct support of a ground maneuver brigade are OPCON to the FSMC commander (brigade surgeon).

4-66. Company Headquarters

The company headquarters (Figure 4-31) is organized into a command element, supply element, and an operations and communications element. The company headquarters provides C² for the company and attached medical units. It also provides general and medical supply, unit-level medical maintenance, NBC operations, and CE support to organic and attached units. For communications, the company headquarters employs 3 tactical radios and a manual switchboard. See Figures 4-12 and 4-13 for FSMC radio and wire nets.

a. *Command Element.* The command element provides C², feeding, billeting, security, training, administration, and discipline of assigned personnel. This element is staffed with a company commander, a field medical assistant/executive officer, a first sergeant, and a unit clerk.

(1) *Company commander.* The company commander plans, directs, and supervises the operations and employment of the company. The commander is also responsible for training, discipline, billeting, and security of the company. This officer, a physician at the DCS, also serves as the brigade surgeon.

(2) *Field medical assistant.* The field medical assistant serves as the company XO. He is the principal assistant to the commander in the employment of company assets. The field medical assistant assures liaison with the S3 of the supported brigade and supervises the activities of the supply and operations/communications elements of the company headquarters. He also supervises and coordinates the security, planning, tactical operations, communications, OPSEC, logistics, and training functions of the company.

b. Supply Element. The supply element provides general supply and armorer support for the company. It provides emergency medical supply and routine medical equipment maintenance support for the company, and for supported medical elements in the BSA. This element is staffed with a unit supply sergeant, a medical equipment repairer, a medical supply specialist, and an armorer.

c. Operations Element. This element plans, coordinates and trains NBC defense functions. It operates the company's wire communications net (Figure 4-14); serves as NCS for the company's operation nets (AM and FM voice—Figures 4-11 and 4-12); and performs unit-level maintenance on all FSMC CE equipment. The operations element is staffed with an NBC operations NCO, a senior radio operator, a single channel radio operator, and a tactical communications systems operator/mechanic.

COMPANY HEADQUARTERS

(Command Element)

- Co Cdr*
- Fld Med Asst/XO
- First Sgt
- Unit Clerk/Swb Opr

(Supply Element)

- Unit Supply Sgt
- Med Eq Repairer
- Med Supply Sp
- Armorer

(Operations Element)

- NBC Operations NCO
- Senior Radio Opr
- Sngl Chan Radio Opr
- Tac Comm Sys Opr/Mech

*Also Brigade Surgeon

Figure 4-31. Organization and staffing of company headquarters, FSMC.

4-67. Treatment Platoon

The treatment platoon operates the DCS. It receives, triages, treats, and dispositions patients based upon their medical condition. This platoon provides for minor surgery, internal medicine, general medicine, and general dentistry. It provides basic diagnostic laboratory, radiological, and patient holding services. The treatment platoon is composed of a platoon headquarters, an area support section, and a treatment section (Figure 4-26). For communications, the platoon employs seven tactical radios and operates its own NCS (Figure 4-13). It is deployed in the FSMC's wire communications net (Figure 4-14).

4-68. Treatment Platoon Headquarters

This is the C² element for the platoon. It directs the disposition of patients and coordinates their evacuation. For communication this element uses the FSMC wire communications net and employs an FM tactical radio mounted in its assigned vehicle.

4-69. Area Support Section

The area support section forms the DCS. It is composed of an area support treatment team, an area support squad, and a patient holding squad. These three elements operate as a single treatment unit and provide unit- and division-level medical support for units operating in the brigade areas. Elements of this section are not used to reinforce or reconstitute Echelon I units. Normally, they are not used on area damage control teams.

4-70. Treatment Section

a. The treatment section (Figure 4-26) is composed of two treatment squads ("first" and "second" squad). These squads perform routine medical care and ATM. Each FSMC treatment squad is identical to the treatment squad of the infantry battalion medical platoon and is oriented toward reinforcing BSA medical assets. Each squad has the capability to operate as separate treatment teams (teams A and B) for a limited period of time. These squads provide troop clinic type services, ATM, and tailgate medicine. The operational medicine officer plans and supervises the activities

of the treatment squad. He examines, treats, and prescribes courses of treatment in the care of patients; provides ATM care for the seriously injured and wounded; and supervises the care and treatment provided patients by other members of his squad.

b. Each squad employs two trauma and two sick call medical equipment sets (one of each type per treatment team), two HMMWV treatment vehicles, and two tactical radios (FM voice). Initially, these squads are located with the area support section to provide an expanded capability for the DCS. But they are primarily oriented toward augmenting or reinforcing combat battalion medical platoons.

4-71. Operations and Employment of the Division Clearing Station

a. The DCS is operated by the FSMC treatment platoon. Its neuropsychiatric and PVNTMED capability is enhanced by the attachment of CSC elements from the division mental health section and a PVNTMED team from the division PVNTMED section. The FSMC may be augmented with a surgical detachment, giving its DCS a surgical capability.

b. The DCS is normally deployed in the vicinity of the brigade trains. It should not be located near targets of opportunity such as ammunition or POL distribution points or other such targets subject to enemy assault. A suggested layout of a DCS is shown in Figure 4-27. Considerations for selecting the location of this facility include—

- (1) Centrally located to provide equal support to the three maneuvering battalions.
- (2) Near accessible evacuation routes.
- (3) Avoidance of likely enemy target areas.
- (4) Near an open area suitable for landing air ambulances.

c. Seriously ill or wounded patients arriving at this facility are given necessary medical treatment and stabilized for movement. Patients

reporting with minor injuries and illnesses are treated within the capability of attending medical and dental officers. Patients are either held for continued treatment and observation for up to 72 hours; evacuated to the MSMC DCS or corps hospital for further treatment, evaluation and disposition; or treated and immediately RTD. Other functions of this facility include—

- Providing consultation and limited clinical laboratory/radiology services.
- Recording all patients seen or treated at the MTF; notifying the brigade S1 and units of all patients from their organization that were processed through the facility.
- Verifying the information contained on the FMC of all patients.
- Monitoring patients when necessary, for NBC contamination prior to medical treatment (refer to FM 8-9, FM 8-285, and TM 8-215).
- Assuring the decontamination and treatment of NBC patients (refer to Appendix E).

NOTE

Patient decon is performed by a pretrained decon team. The team is composed of eight nonmedical personnel from supported units. Patient decon teams perform best when trained and exercised with the supporting medical company.

d. Evacuation from the DCS is performed by ground and air ambulances from the supporting medical brigade/group and ground ambulances from the medical battalion support company.

e. Ammunition and individual weapons (including hand grenades) belonging to patients to

be evacuated out of the division will be collected by the DCS and given to the BDE S4, CS/CSS unit's designated representative, or disposed of as established by command SOP. Patients admitted to the holding facility who are expected to RTD within 72 hours may retain their weapons; such equipment may be given to FSMC armorer for safekeeping pending the patients final disposition. Patients traveling to the division rear for routine medical consultation will retain their individual weapons and equipment.

NOTE

No weapons/ammunition or other equipment such as night vision devices, CE equipment, maps, or classified material will be evacuated out of the division. Patients entering the treatment chain will always retain their protective mask.

4-72. FSMC Ambulance Platoon

a. The FSMC ambulance platoon (Figure 4-28) performs ground evacuation from BASS in the forward areas to the DCS located in the BSA. The FSMC ambulance platoon is staffed with a platoon leader, a platoon sergeant, two aid/evacuation sergeants, six aid/evacuation specialists, and eight medical specialists/ambulance drivers. The ambulance platoon comprises a platoon

headquarters, four ambulance squads (or eight ambulance teams), one HMMWV control vehicle, and eight HMMWV ambulances.

b. The platoon leader leads the platoon and plans for its employment. He establishes and maintains contact with medical platoons of supported maneuver battalions; makes route reconnaissances, develops and issues strip maps; and establishes AXPs for both ground and air ambulances as required.

4-73. Employment of the FSMC Ambulance Platoon

The FSMC ambulance platoon locates with the treatment platoon for mutual support. This platoon is mobile in its operations; all ambulances may be dispatched at any given time. Each of its ambulance teams carries a medical equipment set designed for en route patient care. For communications, the platoon employs nine tactical radios (FM voice), operates its own NCS, and is deployed in the FSMC wire communications net. Prior to start of tactical operations, the platoon establishes contact with supported medical platoons and places one or two ambulances on location with those units. During static situations, however, ambulance teams are retained at their base site to facilitate maximum coverage for all supported units. In addition to providing direct support for maneuver battalions, the ambulance platoon provides area support (routine sick call runs and emergency standby) on an on-call basis for CS units (for example, CAB, DIVARTY, and engineer units) operating within the BSA. The platoon's area of operation is shown in Figure 4-32. The procedures for medical evacuation are discussed in paragraph 4-19c.

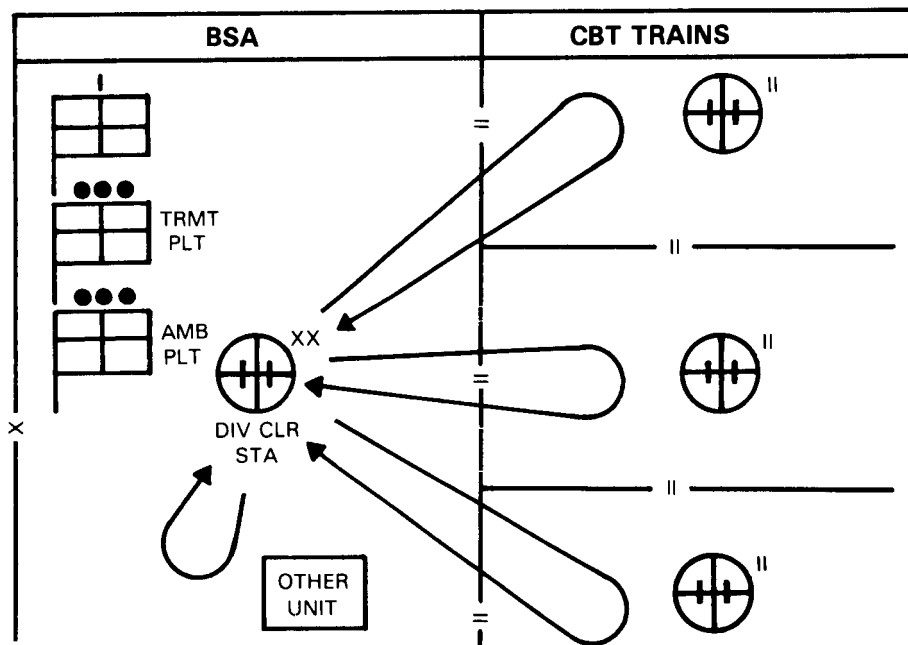

Figure 4-32. FSMC ambulance platoon area of operations.

CHAPTER 5

UNIT-LEVEL HEALTH SERVICE SUPPORT

Section I. TYPE UNITS SUPPORTED

5-1. Mission and Functions

a. The mission and functions of unit-level (Echelon I) HSS elements are—

- Prevention of disease and illness through applied PVNTMED programs.
- Acquisition and immediate treatment of the sick, injured, and wounded.
- Clinical stabilization of the critically injured or wounded.
- Provision for routine medical care (sick call) and the immediate RTD of soldiers "fit to fight."

b. Echelon I HSS is reinforced by Echelon II and III HSS; each providing increased support to the patient. During lulls in operations, unit-level medical personnel conduct tactical and technical proficiency training. When required, they provide instructions to nonmedical personnel in self-aid/buddy aid (first aid), CLS procedures, patient evacuation, field sanitation, and personal hygiene.

c. Unit level HSS within the division is provided by organic medical elements assigned to combat battalions, selected CS battalions, division headquarters, CAB headquarters, and the DIVARTY headquarters. Their purpose is to provide direct HSS to subordinate elements of the organization. This support is provided by medical platoons or sections in the following organizations/units:

- Armored Battalion—Medical Platoon, HHC.

- Mechanized Infantry Battalion—Medical Platoon, HHC.

- Infantry Battalion—Medical Platoon, HHC.

- Division Artillery-Medical Section, Headquarters and Headquarters Battery (HHB).

- Combat Aviation Brigade (CAB)—Medical Section, HHC.

- Field Artillery Battalion (Direct Support), DIVARTY—Medical Section, Headquarters and Headquarters and Service Battery (HHS).

- Attack Helicopter Battalion, CAB—Medical Section, Headquarters and Service Company.

- Reconnaissance Squadron (RECON SQDN), CAB—Medical Section, Headquarters and Headquarters Troop.

- Infantry Division (Light)—Medical Section, HHC.

d. The organic medical platoons and sections above are modular in design, and operate from mobile treatment shelters. They have organic vehicles which provide maximum deployability and mission responsiveness.

5-2. Area Support

Unit level HSS is provided on an area support basis to all organizations and units of the division without organic HSS by medical companies of the FSB, MSB, or DISCOM medical battalion. These companies are located in the BSA and DSA.

Section II. MEDICAL PLATOON

5-3. Assignment

A medical platoon is organic to each combat battalion HHC. The platoon is organized with a

headquarters section, a treatment squad (two treatment teams), an ambulance section, and a combat medic section. The medical platoon is organized as shown in Figures 5-1 and 5-2.

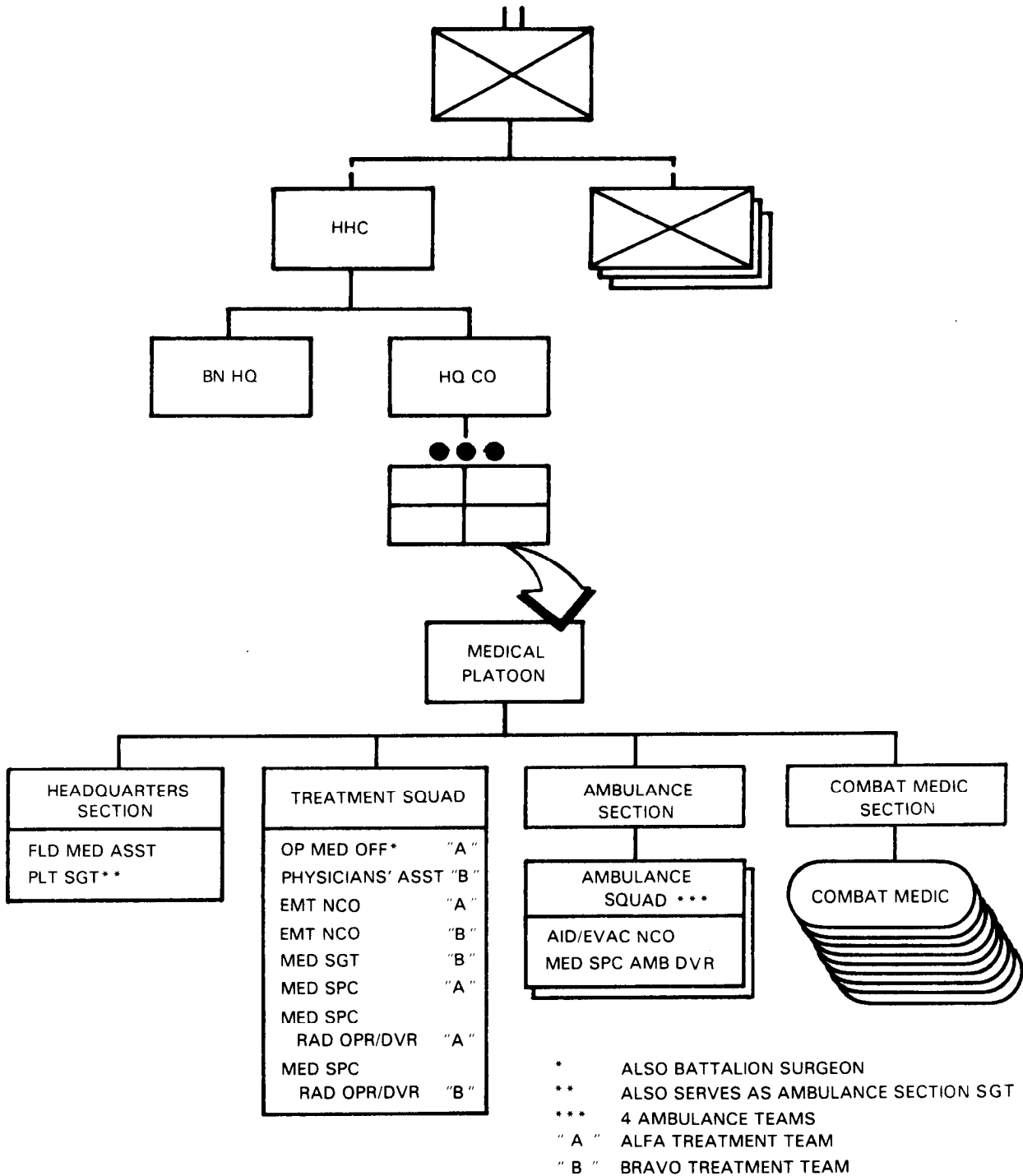
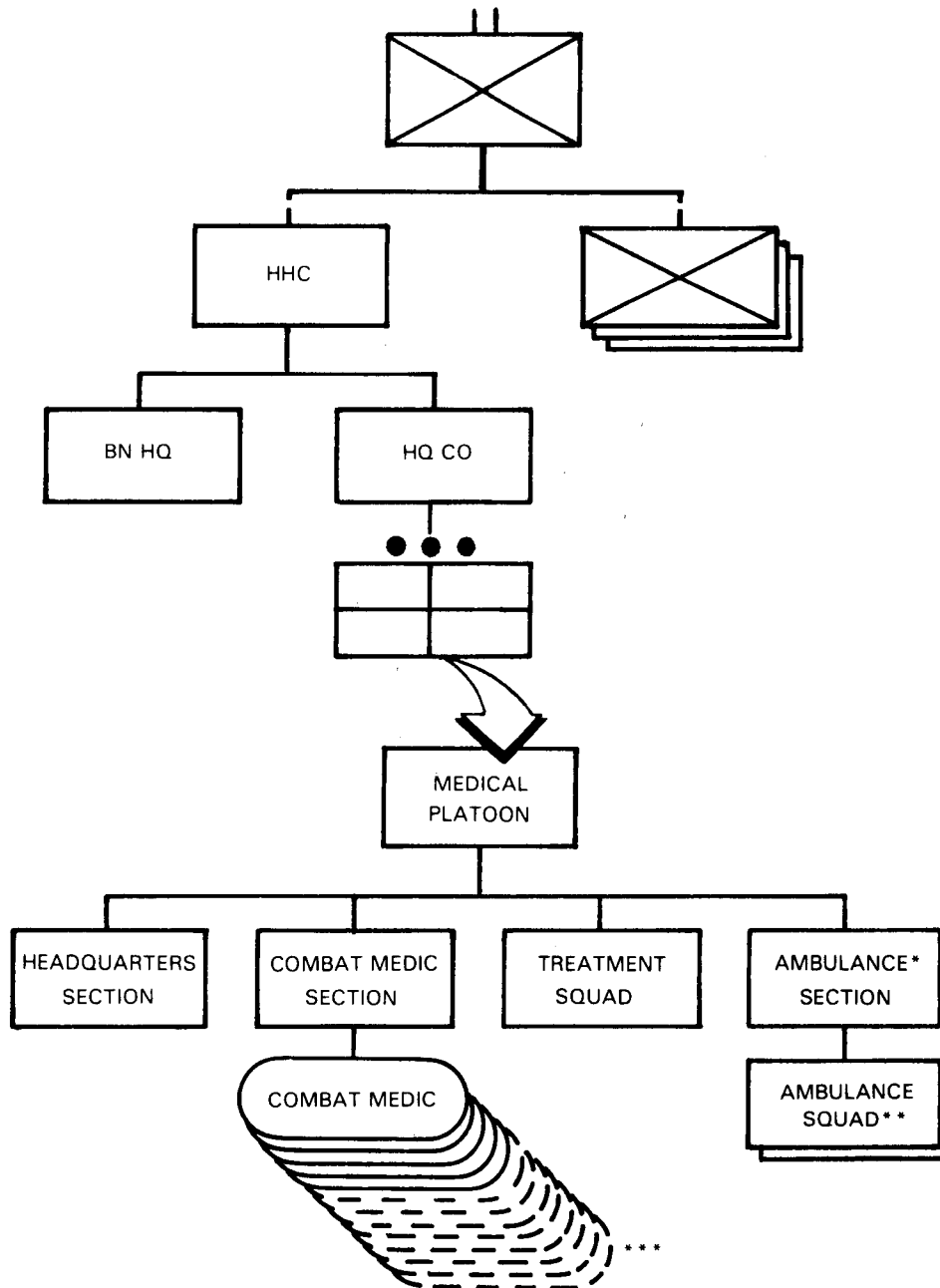

Figure 5-1. Medical platoon, HHC, light infantry battalion.



NOTE:

- * MECHANIZED INFANTRY AND ARMOR UNITS HAVE 4 AMBULANCE SQUADS.
- ** TWO AMBULANCE TEAMS.
- *** AIRBORNE OR AIR ASSAULT UNITS HAVE 12, ARMOR UNITS HAVE 5, AND MECHANIZED INFANTRY UNITS HAVE 13.

Figure 5-2. Medical platoon, heavy battalion.

5-4. Battalion Surgeon

The battalion surgeon/medical platoon leader is the medical advisor to the battalion commander and his staff. He is the supervising physician (operational medicine officer) of the medical platoon treatment squad. This officer is responsible for all medical treatment provided by the platoon. His responsibilities include—

- Planning and directing unit-level HSS for the battalion.
- Advising the battalion commander and his staff on the status of the health of the command.
- Supervising the administration, discipline, maintenance of equipment, supply functions, organizational training, and employment of assigned or attached personnel.
- Examining, diagnosing, treating, and prescribing courses of treatment for patients to include ATM.
- Coordinating the establishment and training of patient decontamination teams.
- Training CLS.
- Supervising the battalion preventive psychiatry program to include training troop leaders in the preventive aspects of stress on soldiers.
- Planning and conducting medical civic action programs (MEDCAP), when directed.

5-5. Platoon Headquarters

a. The headquarters section, under the direction of the battalion surgeon, provides for the command, control, communications, and logistics for the platoon. The platoon headquarters is manned by the field medical assistant and the platoon sergeant. It is normally collocated with the treatment squad to form the BAS. The command post includes the plans and operations functions performed by the field medical assistant. The platoon has access to the battalion wire communication network for communications with all major elements of the battalion and with

supporting units. Wireless communications for this section consists of a tactical FM radio mounted in the platoon headquarters vehicle. The medical platoon employs an FM radio network for HSS operations (Figure 5-3). The headquarters section serves as the net control station for the platoon.

b. The field medical assistant, an MSC officer, is the operations/readiness officer for the platoon. He is the principal assistant to the battalion surgeon for operations, administration, and logistics. The field medical assistant coordinates HSS operations with the battalion S3 and S4, and coordinates patient evacuation with the supporting medical company. This officer serves as the medical platoon leader in the absence of an assigned physician.

c. The platoon sergeant assists in supervising the operations of the platoon. He also serves as the ambulance section sergeant. This NCO prepares reports; requests general supplies as well as medical supplies; advises on supply economy procedures; and maintains authorized stockage levels of expendable supplies. He supervises the activities and functions of the ambulance section to include operator maintenance of ambulances and equipment; operations security (OPSEC); and EMT.

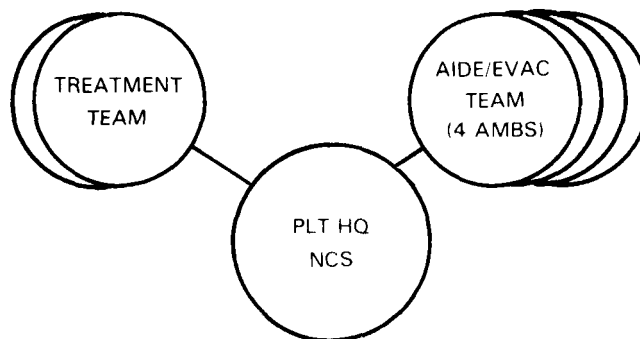

Figure 5-3. Medical platoon operations net.

d. The PA is a warrant officer. He performs general technical health care and administrative duties. The PA is ATM qualified and works under the clinical supervision of the medical officer. He performs the following duties:

- Establishes and operates a BAS or BAS minus (1 treatment team).
- Treats, within his ability, sick or injured patients. He refers those patients requiring treatment beyond his capability to the supervising physician.
- Provides initial resuscitation to wounded personnel.
- Conducts training for battalion personnel in first aid procedures (self-aid/buddy aid), CLS, field sanitation, evacuation of the sick and wounded, and the medical aspects of injury prevention.
- Assists in the conduct of the battalion preventive psychiatry program, to include training troop leaders in the preventive aspects of stress on soldiers.
- Trains medical personnel in emergency medical procedures. See Appendix A for a training procedures guide.

5-6. Treatment Squad

The treatment squad is the basic medical treatment element of the BAS. It provides routine medical care, triage, ATM, and tailgate medicine. This squad is staffed with an operational medicine officer (primary care physician/battalion surgeon), a PA, two EMT NCOs, and four medical specialists (refer to Figure 5-1). The squad's physician, PA, and EMT sergeants are all trained in ATM procedures, commensurate with their occupational positions/specialties.

5-7. Battalion Aid Station/Treatment Squad Operation

Battalion aid station is the generic term used in designating the unit-level medical treatment facility.

a. The treatment squad can split into two treatment teams and operate as two separate aid stations (BAS minus), normally not to exceed 24 hours. In continuous operations, when operating for

longer periods, personnel efficiency and unit capability will tend to deteriorate. Each team employs treatment vehicle(s) with two medical equipment sets (MES); one trauma set and one general sick call set. See Appendix D for an example of the treatment squad in the split team mode.

b. For communications, each treatment team uses a FM tactical radio and is deployed in the medical platoon's operations net. However, under certain tactical conditions the battalion S4 may require BAS elements to use the S4 net.

c. The BAS is under the tactical control of the battalion S4 and is normally deployed in the vicinity of combat trains (see Figures 5-4 and 5-5 for suggested layout of a BAS). To reduce ambulance turnaround time in providing ATM to patients within 30 minutes of wounding, the BAS may split and place its treatment teams as close to maneuvering companies as tactically feasible. The battalion S4 closely coordinates locations for forward positioning CSS elements (including medical treatment elements) with the battalion S3. This is to ensure that the location of these elements is known by commanders of maneuvering and CS forces. Coordination ensures that CSS elements are not placed in the way of friendly maneuvering forces; in line of direct (incoming) fires or supporting fires (outgoing); or in areas subject to be overrun by rapidly advancing enemy forces. Treatment teams situated close to (within 1000 meters of) maneuvering companies in contact must be prepared to withdraw to preplanned, alternate positions on short notice.

d. When maneuvering companies anticipate large numbers of casualties, augmentation of the medical platoon with one or more treatment teams from the FSMC should be made. Augmenting treatment teams are under the tactical control of the battalion S4; but are under the operational control of the battalion surgeon. A suggested scheme of employment is to place a team in close support of each maneuvering company while locating one treatment team in the combat trains. Medical treatment facilities should not be placed near targets of opportunity such as ammunition, POL distribution points, or other targets that may be considered lucrative by the opposing force. Considerations for the location of the BAS should include—

- plan.
- Tactical situation/commander's
 - Expected areas of high casualty density.
 - Security.
 - Protection afforded by defilade.
 - Convergence of lines of drift.
 - Evacuation time and distance.

- Accessible evacuation routes.
- Avoidance of likely target areas such as bridges, fording locations, road junctions, and firing positions.
- Good hardstand drainage.
- Near an open area suitable for helicopter landing.
- Available communication means.

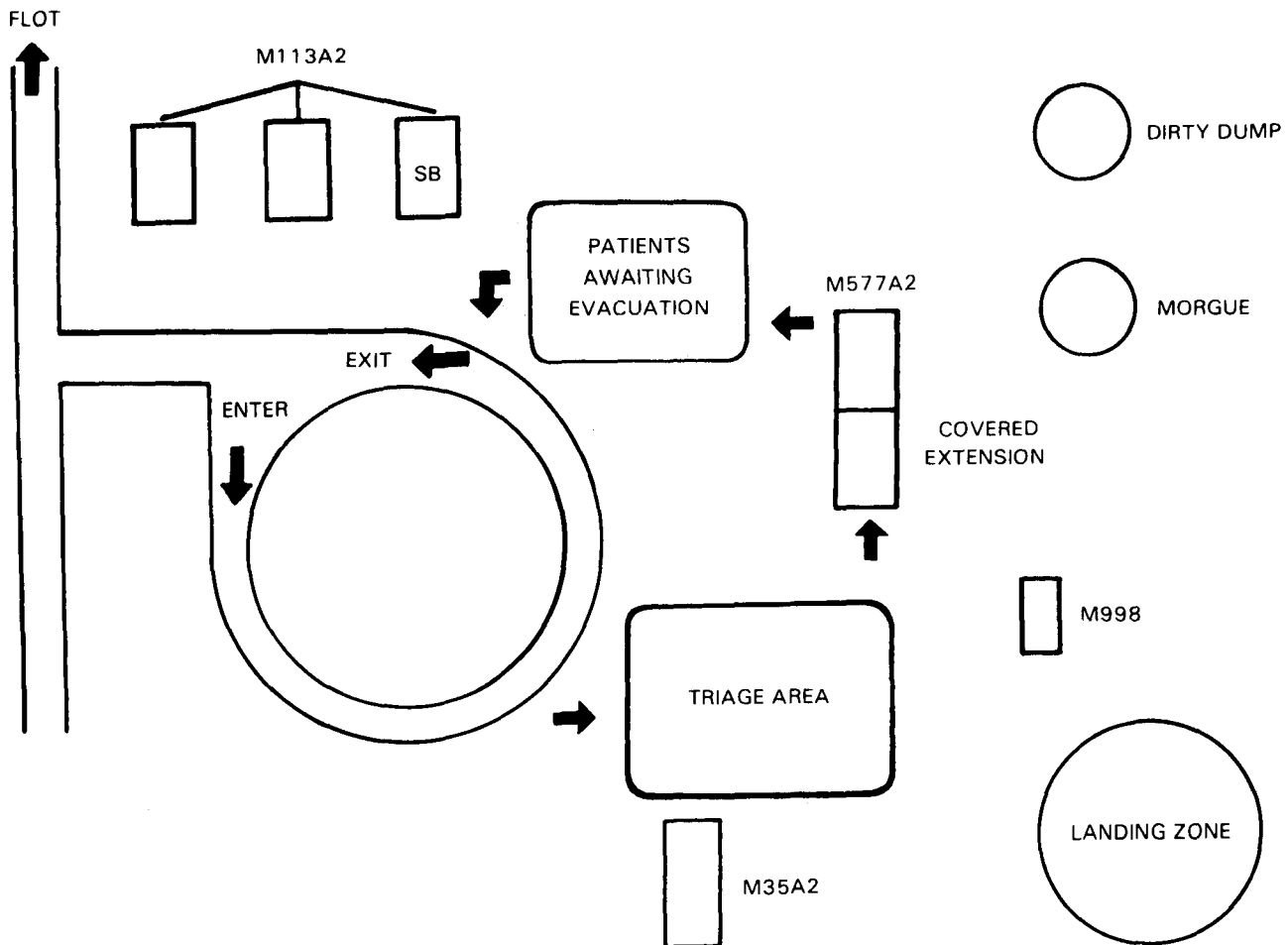

Figure 5-4. Layout of a battalion aid station (heavy).

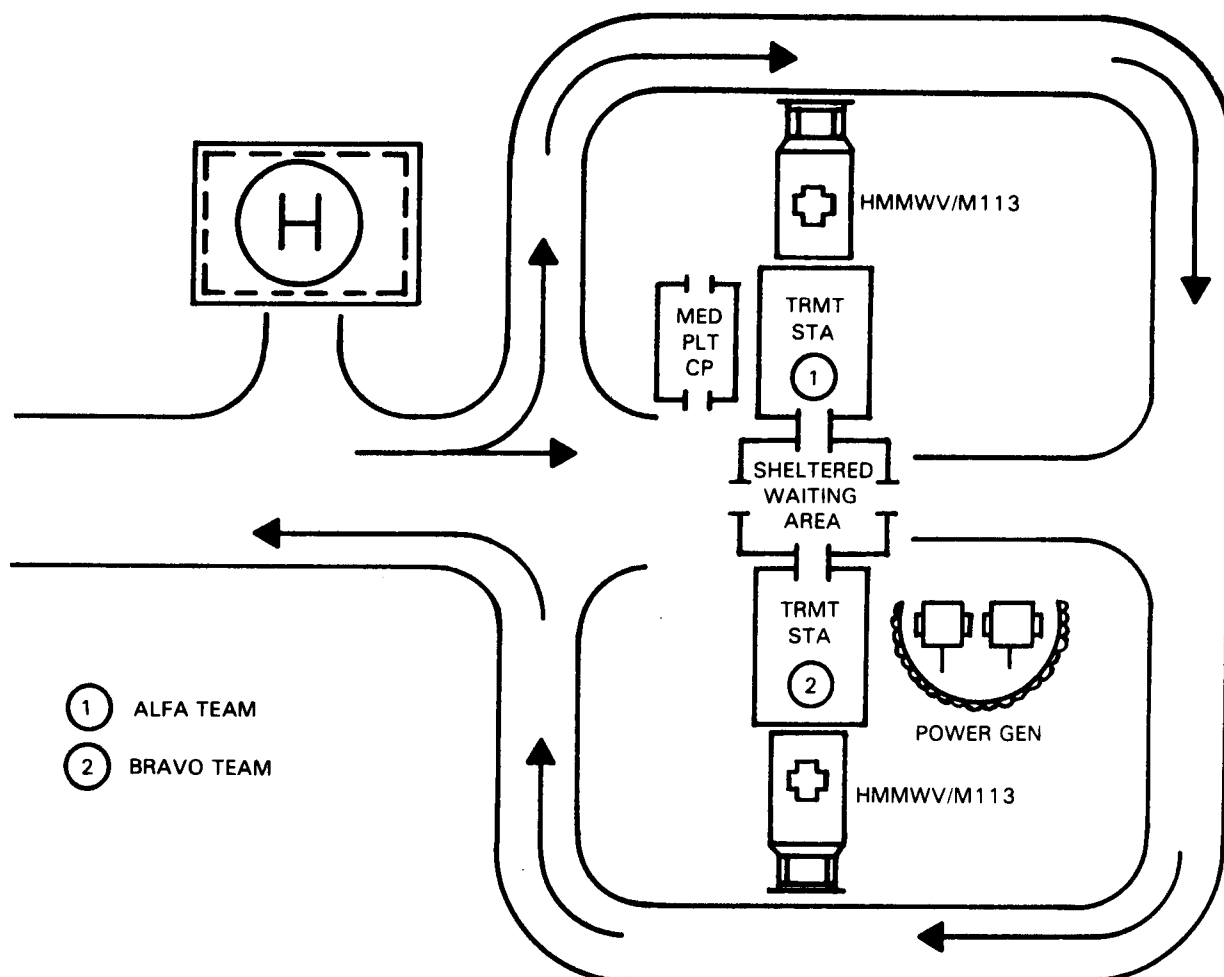

Figure 5-5. Layout of a battalion aid station without M577.

e. At the BAS, patients requiring further evacuation to the rear are stabilized for movement. Constant efforts are made to prevent unnecessary evacuation; patients with minor wounds or illnesses are treated and RTD as soon as possible. Other functions of the BAS include—

- Receiving and recording patients.
- Notifying the S1 of all patients processed through the BAS, giving identification and disposition of patients.
- Preparing field medical cards (FMCs) as required.
- Verifying information contained on FMC of all patients evacuated to the BAS.
- Requesting and monitoring medical evacuation of patients.
- Monitoring personnel, when necessary, for NBC contamination prior to medical treatment.
- Decontaminating and treating NBC patients (refer to TC 8-12, FM 8-9, FM 8-285, TM 8-215, and Chapter 6 of this manual).

NOTE

Patient decontamination (decon) is performed by a pretrained decon team. This team is composed of eight nonmedical personnel from supported units. Patient decon teams perform best when they train and exercise their skills with the supporting BAS (see Appendix E).

f. Evacuation from the BAS is performed by the FSMC's ambulance platoon and by corps air ambulance teams.

g. Patient holding and food service is not available at the BAS. Therefore, only procedures necessary to preserve life or limb, or enable a patient to be moved safely, are performed at the BAS.

h. Ammunition and individual weapons belonging to patients evacuated from the BAS are disposed of as directed by command SOP/policy. All excess equipment collected at the BAS is disposed of by the battalion S4 or as directed by command SOP.

NOTE

Patients will always retain their protective mask.

i. Patients requiring dental treatment are evacuated to the supporting medical company where emergency dental care is provided.

j. Patients requiring optometric services initially report to the BAS. For those patients requiring only routine replacement of spectacles, necessary information is obtained from the individual and forwarded to the division optometry section. The required spectacles are fabricated and forwarded to the BAS for issue to the patient. For optometry services other than routine repair or replacement of spectacles, patients are transported to the optometry section, located in the DCS.

5-8. Combat Medic Section

To foster good interpersonal relations and morale of combat troops, combat medics are attached to maneuver companies on a continuing basis. However, during lulls in combat operations, they should return to the medical platoon for consultation and proficiency training. Functions of combat medics are as follows:

- Performs triage and EMT for the sick and wounded.
- Arranges medical evacuation for litter patients and directs ambulatory patients to patient collecting points or to the BAS.
- Initiates the FMC for the sick and wounded and, as time permits, prepares an FMC on deceased personnel.
- Screens, evaluates, and treats, within his capabilities, those patients suffering minor illnesses and injuries. He RTD those patients requiring no further attention.
- Keeps the company commander and the battalion surgeon (or the PA in the absence of the surgeon) informed on matters pertaining to the health and welfare of the troops.
- Maintains sufficient quantities of medical supplies to support the tactical situation.
- Serves as a member of the unit field sanitation team. In this capacity, he advises the commander and supervises unit personnel on matters of personal hygiene and field sanitation (FM 21-10-1).

5-9. Ambulance Section

a. Medical platoon ambulances provide evacuation within the battalion. Ambulance teams provide medical evacuation and en route care from the soldier's point of injury to the BAS. In mass casualty situations, nonmedical vehicles may be used to assist in casualty evacuation as directed by the commander. Plans for the use of nonmedical vehicles to perform medical evacuation should be included in the battalion's tactical SOP.

NOTE

Performing operators maintenance on ambulances is an important part of each ambulance team's duties.

b. Under the modular medical system, the ambulance squad consists of two ambulance teams.

(1) The aid/evacuation NCO performs—

- Triage and advanced EMT procedures in the care and management of trauma patients.

- Assists in the care and management of battle fatigue patients.

- Prepares patient for movement.

- Provides patient care en route.

- Maintains contact with supported units.

- Collects casualties.

- Performs NBC detection procedures.

(2) The medical specialist/ambulance driver is trained in EMT procedures. He operates and maintains the ambulance and all on-board equipment. He assists the aid/evacuation NCO in the care and handling of patients.

c. Specific duties of the ambulance team are to—

- Maintain contact with supported elements.

- Find and collect the wounded.

- Administer EMT as required.

- Initiate or complete the FMC.

- Evacuate litter patients to the BAS.

- Director guide ambulatory patients to the BAS.

- Perform triage when necessary.

- Provide Class VIII resupply to combat medics.

- Serve as messengers within medical channels.

d. The number of ambulance squads in a section varies and is based on the type of parent organization. The infantry, airborne, and air assault maneuver battalions ambulance sections have two ambulance squads; each is equipped with high mobility multipurpose wheeled vehicle (HMMWV) ambulances. The heavy combat maneuver battalions ambulance sections have eight ambulance squads equipped with M-113 tracked ambulances.

5-10. Employment and Functions of the Ambulance Team

a. The ambulance team is a mobile combat medic team. Its function is to collect, treat, and evacuate the sick and wounded to the nearest treatment station or AXP. For communications, the ambulance team employs an FM tactical radio mounted on its assigned ambulance. The team is deployed in the medical platoon's operations net; however, in certain circumstances it may operate in the S4 net or as established by the battalion SOI.

b. The ambulance teams routinely deploy with the maneuver company trains; however, it operates as far forward as the tactical situation permits, and frequently finds and treats patients who have not been seen by the company medic. This team, when operating in a company's AO, is normally under the tactical control of the company XO or first sergeant, but remains under the technical and operational control of the medical platoon. An ambulance team is normally designated to support a specific company. To become familiar with the specific terrain and battlefield situation, the team maintains contact with the company during most combat operations.

c. During static situations where the company is not in enemy contact or is in reserve, the

team returns to the BAS to serve as back-up support for other elements in contact. However, during movement to contact, the ambulance team immediately deploys to its regularly supported company. During combat operations, the team may dismount (leaving the ambulance in the trains area), find, treat, and move patients to safety, and later evacuate them to the BAS. When moving patients to the ambulance location, patient collecting point, or company aid post, the team is normally assisted by nonmedical personnel.

a continuous movement of patients. Medical evacuation is the process of moving patients from the point of injury or illness to an MTF or between MTFs. Each stop in the process is to provide medical treatment to enhance the patient's early RTD or to stabilize him for further evacuation. The responsibility for patient evacuation rests with the level of HSS to which the patient is to be evacuated (see Patient Evacuation Flow, Figure 5-6). Ambulances go forward, pickup patients, and move them to the supporting MTFs.

5-11. Medical Evacuation

a. Optimum patient care and treatment is dependent upon an evacuation system that provides

(1) Ambulance teams of the medical platoon evacuate patients from the company aid post or patient collecting points to the BAS.

(2) Ambulance squads of the FSMC evacuate patients from the BAS to the DCS.

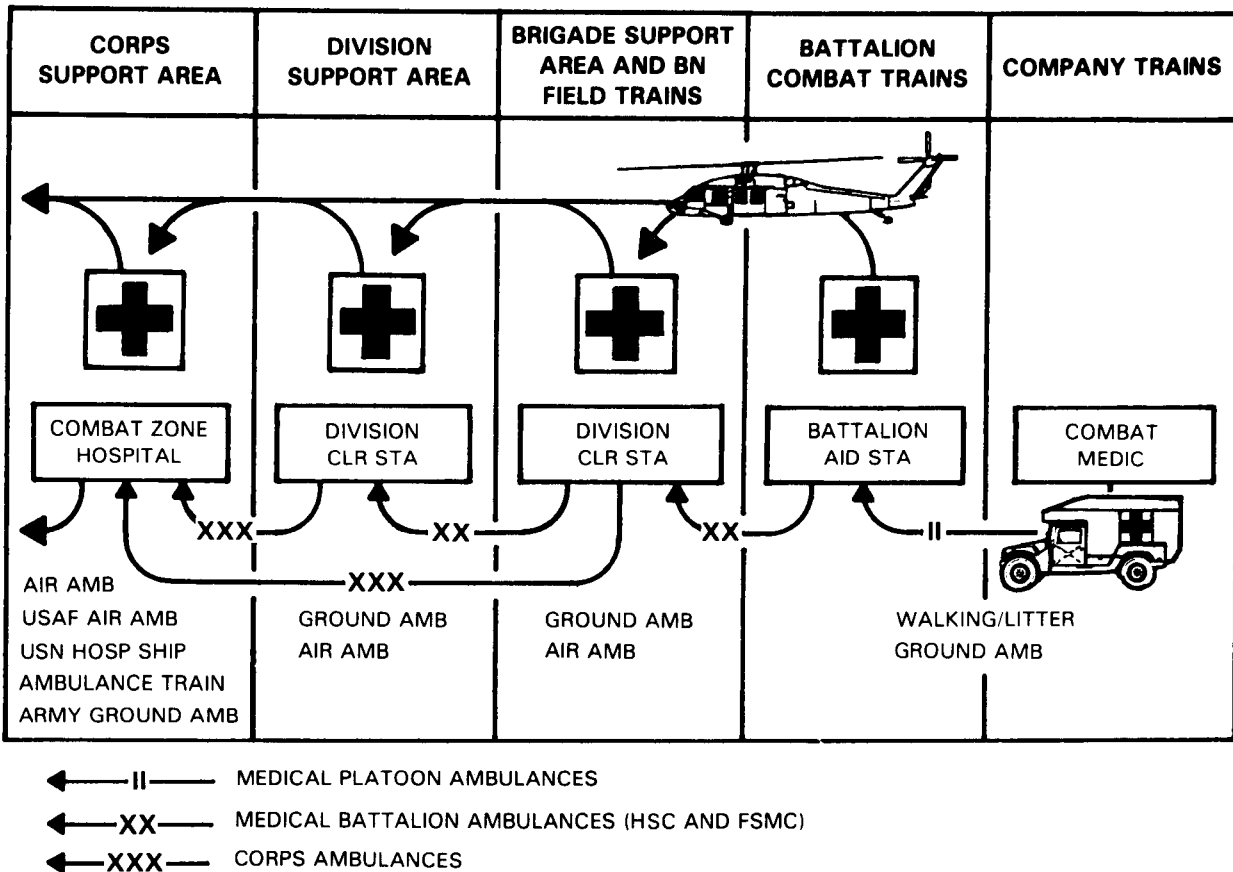

Figure 5-6. Patient evacuation flow.

b. An ambulance shuttle system may be set up between the FSMC DCS and the BAS. An AXP is established (Figure 5-7) so that ambulances are moving forward as others move rearward; thus

enabling a continuous rearward evacuation flow, while decreasing ambulance turnaround time. Patients are evacuated no further to the rear than their conditions require.

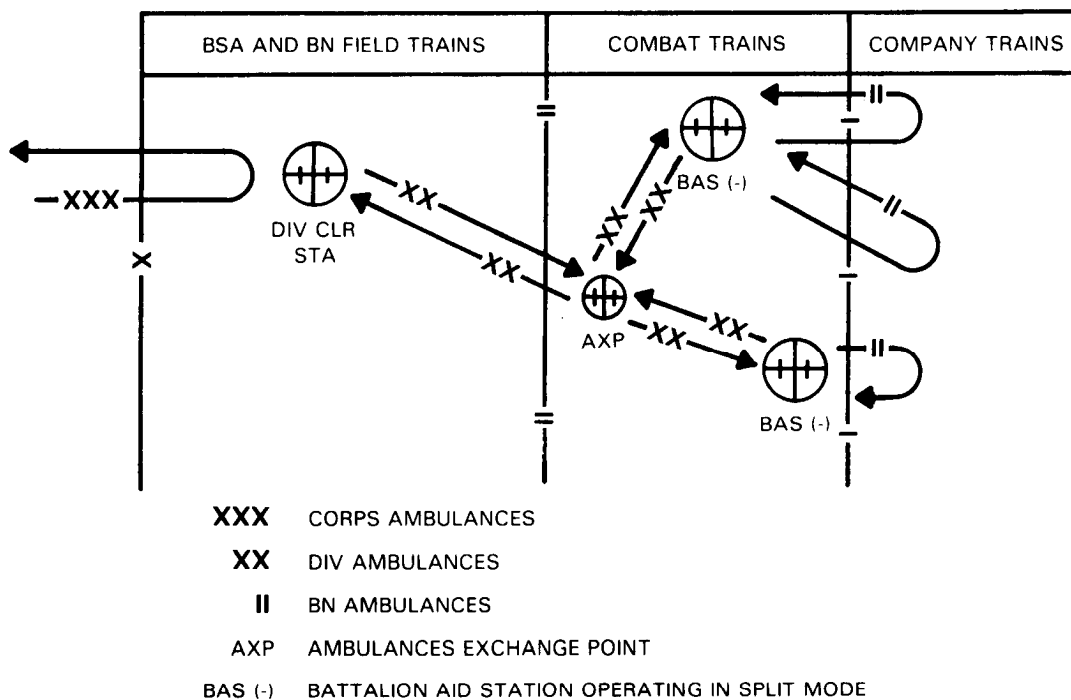

Figure 5-7. Ground ambulance shuttle system.

c. Aeromedical evacuation in the CZ should be used to the maximum extent possible for critically ill or wounded patients. Refer to Appendix F for medical evacuation request procedures. Normally, ground ambulances are used to evacuate the minimally ill or wounded and for those patients who cannot be evacuated by air. The specific mode of evacuation is determined by the patient's condition, aircraft/vehicle availability, the tactical situation, and weather conditions (METT-T factors). When both air and ground ambulances are used, specific factors are considered in determining which patients are to be evacuated by air and which are to be evacuated by ground ambulances (see FM 8-10-6). Normally, the physician or PA treating the patient (or the senior medic in their absence) makes this

determination; it is based on the medical condition of the patient. However, the goal is to get the trauma patient to the initial treatment/ATM element within 30 minutes of wounding.

5-12. Medical Supply

a. The medical platoon maintains a 2-day (48-hour) stockage of medical supplies. Normal medical resupply of the platoon is performed by the DMSO through backhaul or in coordination with the movement control office (MCO). Medical resupply may also be by preconfigured Class VIII packages (PUSH packages) throughput from the forward MEDSOM/MEDLOG battalion located in the corps support area (Figure 5-8).

Paragraph 5-13 implements STANAG 2128.

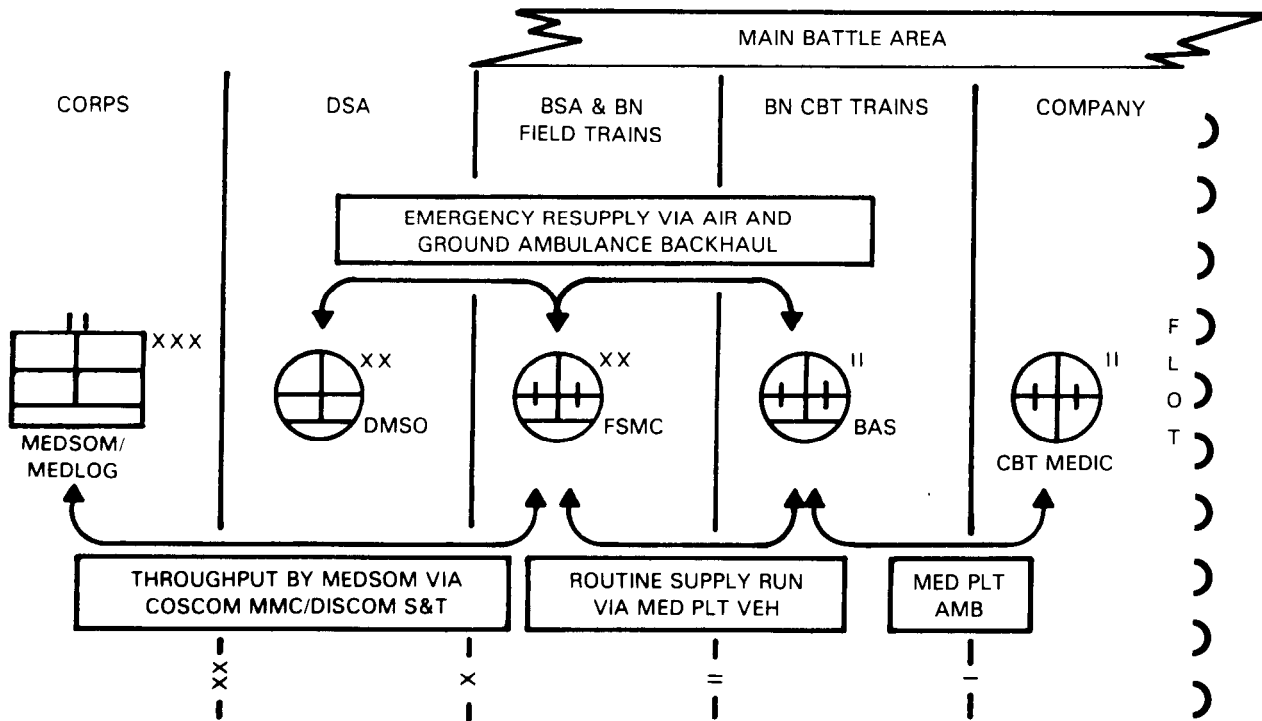

Figure 5-8. Flow of Class VIII supplies.

b. In a tactical environment, the emergency medical resupply (ambulance backhaul) system is used. In this environment, medical supplies are obtained informally and as rapidly as possible, using any available medical transportation assets. The medical platoon submits supply requests to the supporting FSMC, who in turn fills requests and ships supplies forward. Request for items not available at the FSMC are forwarded to the DMSO; the request is filled from division stocks and shipped to the requestor by the most expedient means available. Air ambulances from corps and ground ambulances from the DISCOM transport medical supplies directly to BASSs. Class VIII resupply of combat medics is performed by ambulances of the medical platoon.

5-13. Property Exchange

Whenever a patient is evacuated from one treatment facility to another or is transferred from one ambulance to another, medical items such as casualty evacuation bags (cold weather type bags), blankets, litters, and splints remain with the patient. To prevent rapid and unnecessary depletion of supplies and equipment, the receiving agency exchanges like property with the transferring agency. Medical property accompanying patients of allied nations will be disposed of in accordance with command SOP and STANAG 2128, if applicable.

Section III. MEDICAL SECTIONS AND SPECIAL PURPOSE MEDICAL PLATOONS

5-14. Combat Support Unit and Division Headquarters Medical Section

Medical sections are organic to CS units and the division headquarters. With the exception of the

combat engineer battalion, a medical section in the light division normally consists of one treatment module. These treatment modules are designed to provide unit-level HSS for personnel of supported units. A medical section is relatively small in

comparison to a medical platoon; therefore, it will require augmentation from a supporting medical company in mass casualty situations.

organized as shown in Figure 5-9. Personnel staffing of this section includes a DIVARTY surgeon/operational medicine officer, a section sergeant/EMT NCO, and two medical specialists.

5-15. Medical Section, HHB Division Artillery

a. Organizations and Functions. The DIVARTY medical section/treatment team is

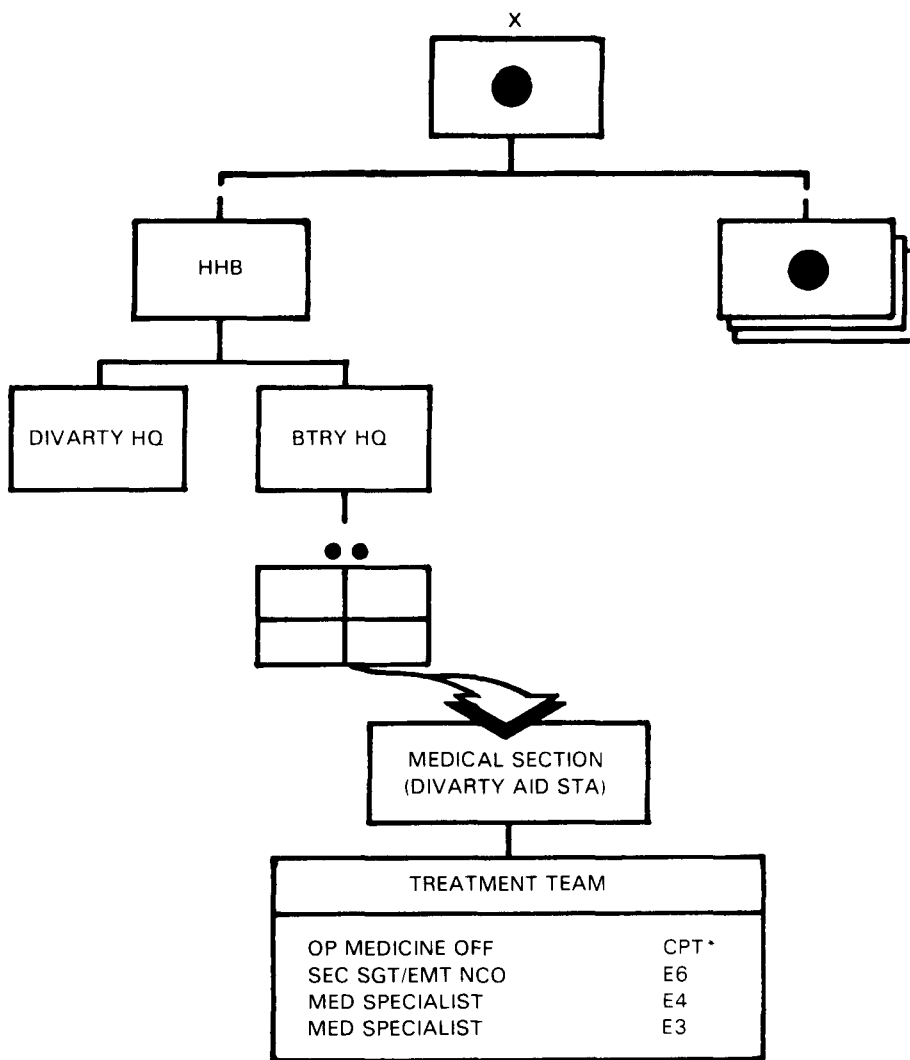

Figure 5-9. Medical section, HHB, division artillery.

(1) *DIVARTY Surgeon.* officer is the medical advisor to the DIVARTY commander and his staff. He is the primary care physician of the DIVARTY and is also the supervising physician for PA/medical section

leaders in the three FA battalions. Certain situations may require that the clinical supervision of PAs in FA units be passed to the physician in charge of the nearest supporting MTF. Such requirements, however, are coordinated through the

division surgeon. The DIVARTY surgeon is responsible for medical treatment provided by DIVARTY medical personnel (inclusive of medical personnel assigned to FA battalions). His duties include—

- Operating the DIVARTY aid station.

- Planning and directing unit-level HSS for members of the DIVARTY headquarters and FA battalions.

- Arranging for division-level HSS.

- Arranging for patient evacuation to the DCS.

- Supervising the administration and maintenance of equipment, the supply function, technical training, and the employment of medical personnel.

- Examining, diagnosing, treating, and prescribing courses of treatment for patients to include ATM for the trauma patient.

- Coordinating patient evacuation.

(2) *Section Sergeant.* The section sergeant, who is also an EMT NCO, assists the medical officer in accomplishing his duties and supervises the medical specialists. He prepares reports, requests general and medical supplies, maintains supply economy procedures, and maintains authorized stockage level of expendable supplies. This NCO also performs triage and ATM procedures in the care of trauma and NBC-insulted patients, and care and management of battle fatigue patients. He also performs routine patient care and NBC detection procedures. His duties further include—

- Establishing and operating the DIVARTY aid station.

- Maintaining the patient accountability/casualty reporting system.

- Maintaining medical equipment sets.

- Conducting tactical and technical proficiency training for subordinate members of the section.

- Conducting sanitation inspections of troop living areas, food service areas, waste disposal areas, and potable water distribution points and equipment.

(3) *Medical Specialists.* These specialists assist the section sergeant in accomplishing his duties. They perform triage and EMT. Their specific duties include—

- Erecting and breaking down field medical shelter systems, to include chemical/biological protective shelters.

- Performing patient care.

- Initiating patient records (FMC).

- Maintaining the patient daily disposition log.

- Operating and maintaining assigned vehicle, tactical radio, and power generation equipment. (Also may serve as a member on the battery field sanitation team.)

b. Employment. The medical section establishes a BAS near the DIVARTY headquarters and provides unit-level medical service for members of the DIVARTY headquarters and headquarters battery.

(1) The section employs a HMMWV treatment vehicle, a cargo trailer, and two medical equipment sets: one trauma treatment set and one general sick call set.

(2) For communications, the section employs a telephone set (TA 312/PT) and is deployed in the HHB wire net. It employs an FM tactical radio and is deployed as designated by the DIVARTY SOI. This section also has access to the supporting medical company's tactical operations net to request division-level HSS.

c. Operations. Paragraph 5-7 describes BAS operations; these are equally applicable to the

DIVARTY BAS. Figures 5-4 and 5-5 show suggested layouts of a BAS.

d. Medical Evacuation. The DIVARTY HHB medical section has no medical evacuation assets. Evacuation of patients to and from the DIVARTY BAS is provided by the supporting medical company in the DSA.

e. Medical Supply. The medical section maintains a 2-day (48-hour) stockage level of medical supplies for the HHB. Routine requests for medical supplies are submitted through command channels to the DMSO. Supplies may be picked up by the requesting unit or forwarded to the DIVARTY BAS during routine ambulance runs. For emergency resupply procedures, see paragraph 5-12 b.

f. Property Exchange. See paragraph 5-13.

5-16. **Medical Section, Headquarters and Headquarters Support Company, Direct Support Field Artillery Battalion**

This section is organic to the Headquarters and Headquarters Support Company (HHS) of the direct support (DS) FA battalions; it is organized as shown in Figure 5-10. Personnel staffing for this medical section includes a section leader/PA, a section sergeant/EMT NCO, two medical specialists, and three combat medics (battery aidmen).

a. Section Leader/Physicians' Assistant. The PA is an advisor to the battalion commander and his staff. He is the primary medical care provider for the battalion and supervises all activities of the medical section. The PA is trained in ATM procedures and works under the clinical supervision of a medical officer. He is responsible to the supervising physician for all treatment provided by medical personnel of the section. His specific duties include—

- Establishing and operating the BAS.
- Planning and supervising unit-level HSS and coordinating division-level HSS for the battalion.

- Treating, within his ability, patients reporting to him.

- Referring patients who require treatment beyond his capability to the supervising physician.

- Providing initial resuscitation (ATM) for the wounded.

- Training medical personnel and CLS in emergency medical procedures.

b. Section Sergeant. This NCO assists the PA in accomplishing his duties. The specific duties of this NCO are the same as those described for the medical section sergeant in the DIVARTY HHB (refer to paragraph 5-15 a (2)).

c. Medical Specialists. The duties and functions of these specialists are the same as those discussed in paragraph 5-15 a (3).

d. Combat Medics. Combat medics are allocated to a DS FA battalion on the basis of one to each firing battery. The duties and functions of combat medics are described in paragraph 5-8.

e. Employment. The medical section establishes a BAS near the DIVARTY headquarters and provides unit-level HSS.

(1) The section employs a HMMWV treatment vehicle, a cargo trailer, and two medical equipment sets: one trauma treatment set and one general sick call set.

(2) For communications, the section employs a telephone set (TA 312/PT) and is deployed in the HHS wire communications net. It also employs an FM tactical radio and is deployed in the net designated by the DIVARTY SOI. This section also has access to the supporting medical company's tactical operations net to request division-level HSS.

f. Operations. Paragraph 5-7 describes a BAS operation; these are equally applicable to the FA BAS. Figures 5-4 and 5-5 show suggested layouts of a BAS.

g. Medical Evacuation. The FA battalion's HHS medical section has no medical evacuation assets. Evacuation of patients to and from the BAS

is provided by the supporting medical company in the BSA.

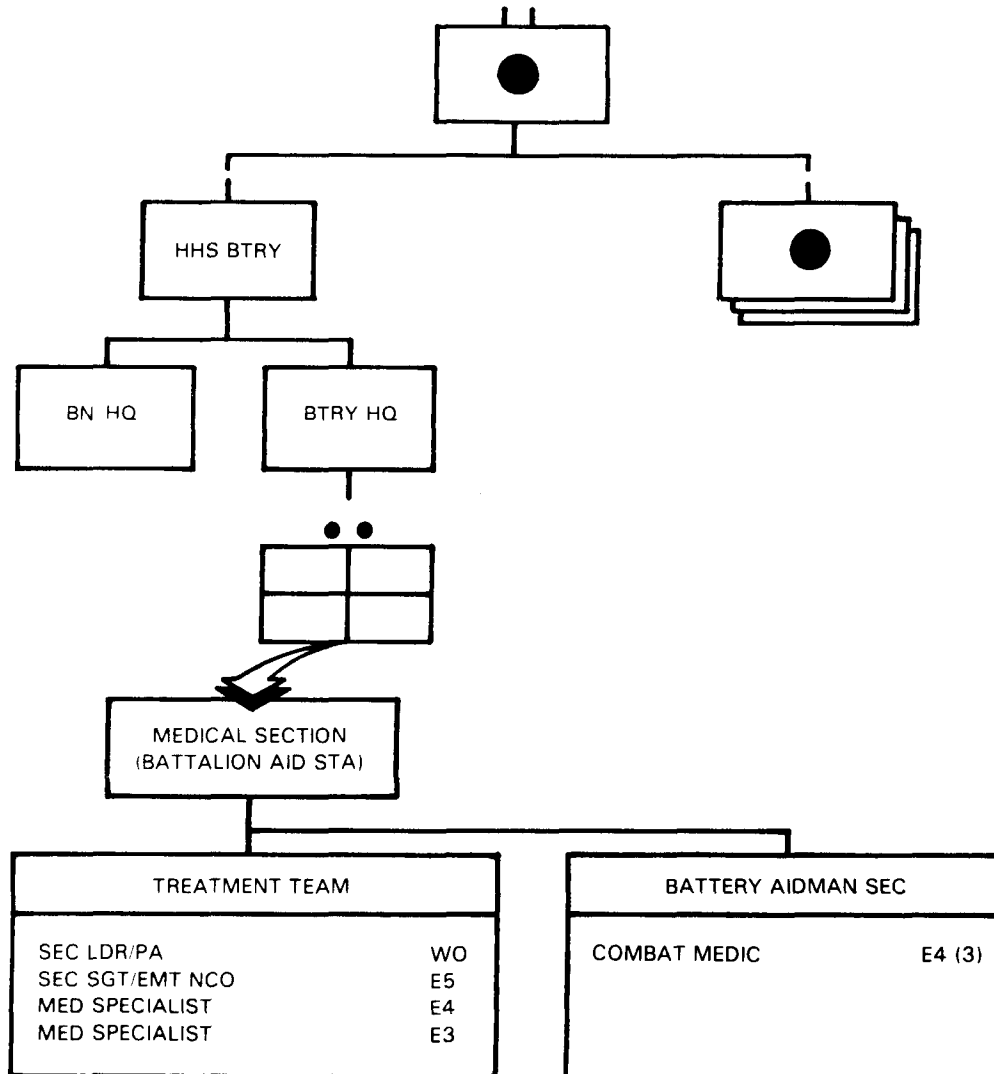

Figure 5-10. Medical section, HHS, direct support field artillery battalion.

h. Property Exchange. See paragraph 5-13.

5-17. Medical Section, Headquarters and Headquarters Company Combat Aviation Brigade/Combat Aviation Squadron

a. Organization and Functions. The CAB medical section is organized as shown in Figure 5-11. Personnel staffing this section include a flight surgeon, an assistant flight surgeon, a section sergeant/EMT NCO, and two medical specialists.

(1) The flight surgeon (brigade surgeon) is the medical advisor to the CAB commander and his staff. He is the primary care physician of the brigade. The flight surgeon is responsible for medical treatment provided by the medical section (brigade aid station). His duties include—

- Operating the brigade aid station.
- Examining and determining the medical qualification for flying status of

aviators within the brigade headquarters; or aviators referred to him by units without a flight surgeon.

- Planning and directing unit-level HSS for members of the brigade headquarters.
- Arranging for evacuation of patients to the DCS.
- Arranging division-level HSS.
- Supervising the administration and maintenance of equipment, the supply function, technical training, and the employment of medical personnel.

- Examining, diagnosing, treating, and prescribing courses of treatment for patients to include ATM for trauma patients.

(2) The assistant flight surgeon assists the flight surgeon in performance of his duties. He serves as the aviation brigade flight surgeon in the absence of the flight surgeon. His duties include—

- Examining and determining the medical qualification for flying status of aviators within the brigade headquarters; or aviators referred to his treatment section by units without a flight surgeon.
- Examining, diagnosing, treating, and prescribing courses of treatment for patients to include ATM for trauma patients.

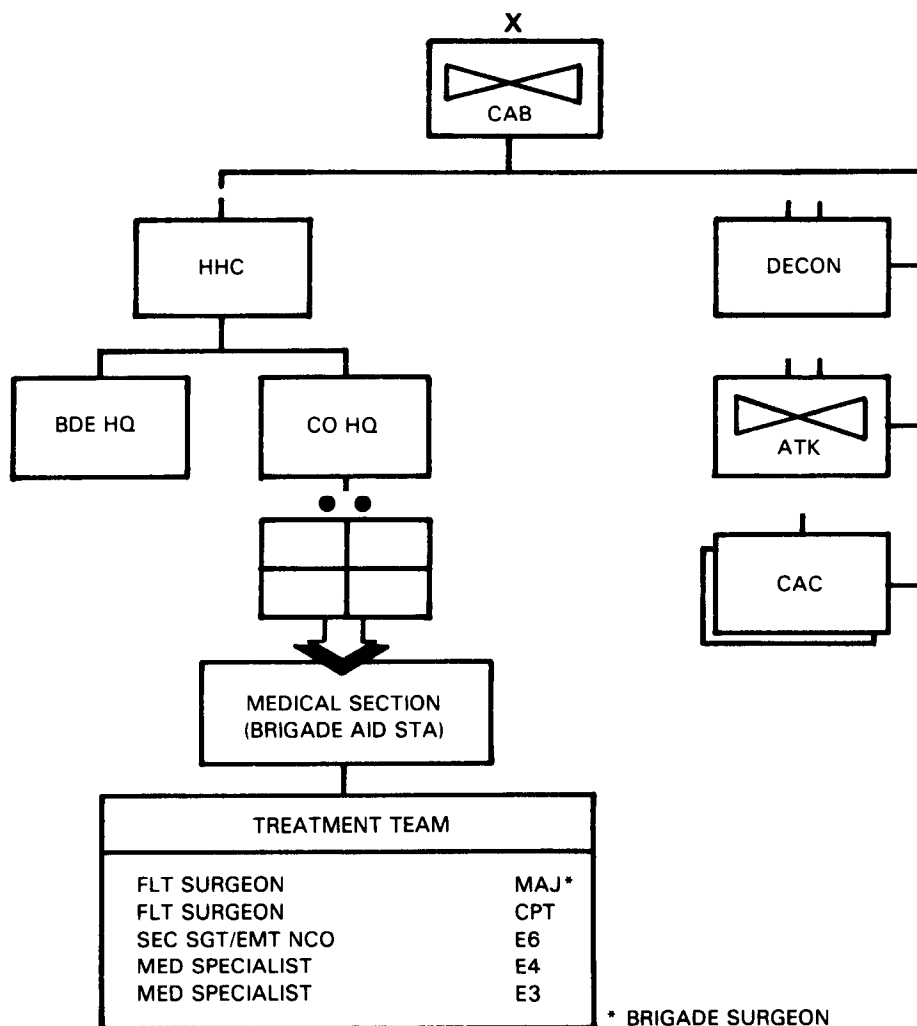

Figure 5-11. Medical section, HHC combat aviation brigade.

b. Employment. See paragraph 5-15 *b* for employment considerations.

c. Operations. Paragraph 5-7 describes aid station operations; these are equally applicable to the DIVARTY BAS. Figures 5-4 and 5-5 show suggested layouts of a BAS.

d. Medical Evacuation. The brigade HHC medical section has no medical evacuation assets. Evacuation of patients is provided by the supporting medical company.

e. Medical Supply. See paragraph 5-12.

f. Property Exchange. See paragraph 5-13.

5-18. Medical Section, HHC Attack Helicopter Battalion, CAB.

a. Organization and Functions. The attack helicopter battalion medical section is organized as shown in Figure 5-12. Personnel staffing this section include a section sergeant/EMT NCO, and two medical specialists. For further explanation, see paragraph 5-15 *a*.

b. Property Exchange. See paragraph 5-13.

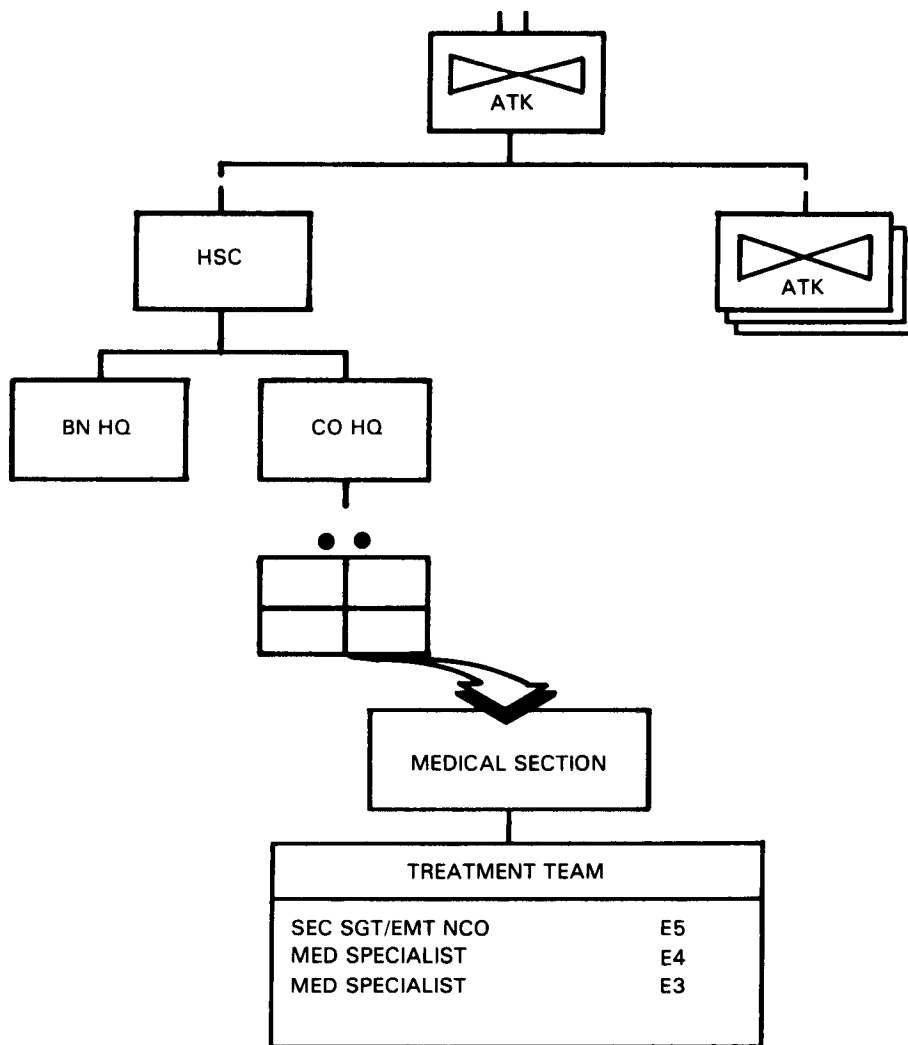

Figure 5-12. Medical section, HHC attack helicopter battalion.

5-19. Medical Platoon, HHT Reconnaissance Squadron, CAB.

a. Organization and Functions. The HHT reconnaissance squadron CAB medical platoon is organized as shown in Figure 5-13. Personnel staffing this platoon include a flight surgeon, a PA, a section sergeant/EMT NCO, two medical

specialists, six combat medics, four aid evacuation NCOs, and two aid evacuation specialists.

(1) For flight surgeon responsibilities, see paragraph 5-17.

(2) The PA performs general technical health care and administrative duties (refer to paragraph 5-5).

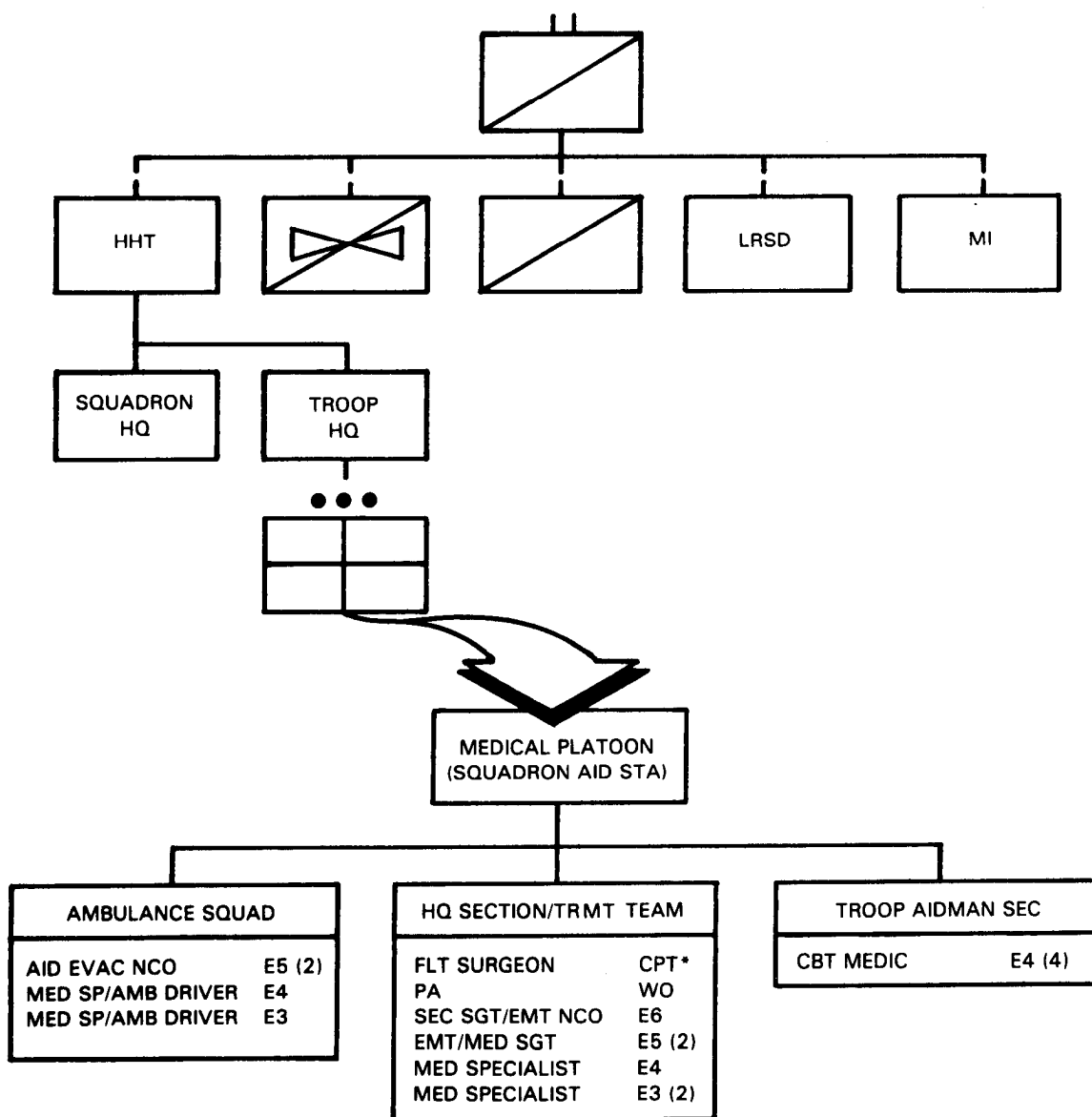

Figure 5-13. Medical platoon, HHT reconnaissance squadron.

b. Section Sergeant. This NCO assists the PA in accomplishing his duties. The specific duties of this NCO are the same as those described for the medical section sergeant in the DIVARTY HHB (refer to paragraph 5-15 a (2)).

c. Medical Specialists. The duties and functions of these specialists are the same as those discussed in paragraph 5-15 a (3).

d. Combat Medics. These aidmen are allocated to a squadron on the basis of one to each firing troop. The duties and functions of combat medics are described in paragraph 5-8.

e. Ambulance Squad. Paragraph 5-10 describes duties of ambulance squad members.

f. Employment. The medical section establishes a BAS near the squadron headquarters and provides unit-level medical service for members of the squadron.

(1) The section employs a HMMWV treatment vehicle, a cargo trailer, and two medical equipment sets: one trauma treatment set and one general sick call set.

(2) For communications, the section employs a telephone set (TA 312/PT) and is deployed in the HHS wire communications net. It also employs an FM tactical radio and is deployed in the net designated by the squadron SOI. This section also has access to the supporting medical company's tactical operations net for requesting division-level HSS.

g. Operations. Paragraph 5-7 describes an BAS operation; these are equally applicable to the squadron BAS. Figures 5-4 and 5-5 show suggested layouts of a BAS.

h. Medical Evacuation. Evacuation of patients from the BAS is provided by the supporting medical company.

i. Medical Supply. The medical section maintains a 2-day (48-hour) stockage level of medical supplies for the squadron. Routine requests for medical supplies are submitted through command channels to the DMSO. Supplies may be picked up by the requesting unit or forwarded to the

BAS during routine ambulance runs. For emergency resupply procedures, see paragraph 5-12.

j. Property Exchange. See paragraph 5-13.

5-20. Medical Section, HHC Division Headquarters

a. Organizations and Functions. The HHC division headquarters medical section is organized as shown in Figure 5-14. Personnel staffing of this section includes an operational medicine officer, a section sergeant/EMT NCO, two medical specialists, and two aid evacuation specialists.

(1) *Operational medical officer.* The operational medical officer is responsible for medical treatment provided by HHC medical personnel. The specific duties of this medical officer are the same as those described in the DIVARTY HHB (refer to paragraph 5-15 a (1)).

(2) *Section sergeant.* Refer to paragraph 5-15 a (2).

(3) *Medical specialists.* Refer to paragraph 5-15 a (3).

(4) *Aid evacuation team.* Paragraph 5-10 describes employment of ambulance teams.

b. Employment. The medical section establishes a BAS near the division headquarters and provides unit-level HSS for members of the division headquarters and headquarters company.

(1) The section employs a HMMWV treatment vehicle, a cargo trailer, and two medical equipment sets: one trauma treatment set and one general sick call set.

(2) For communications, the section employs a telephone set (TA 312/PT) and is deployed in the HHB wire communications net. It also employs an FM tactical radio and is deployed in the net designated by the division SOI. This section also has access to the supporting medical company's tactical operations net to request division-level HSS.

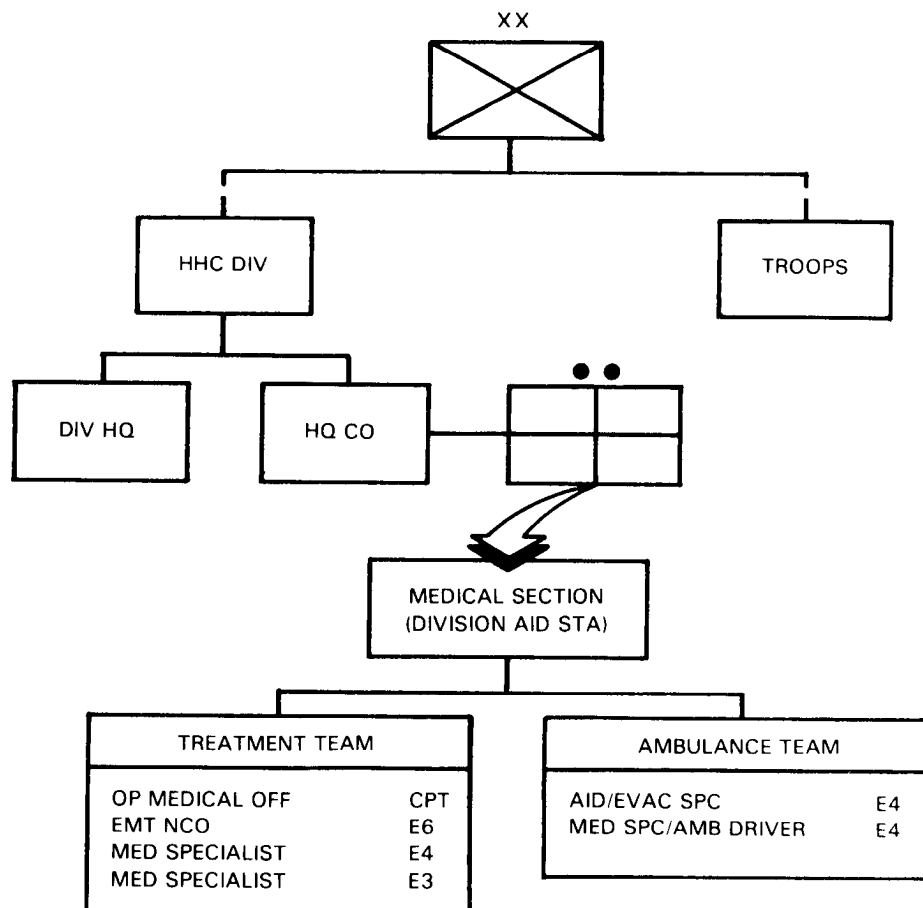

Figure 5-14. Medical section, HHC, division headquarters.

5-21. Medical Platoon, HHC Combat Engineer Battalion

a. Organization and Functions. The combat engineer battalion medical platoon is organized as shown in Figure 5-15. Personnel staffing this section include an operational medical officer, a section sergeant/EMT NCO, an emergency medical NCO, two medical specialists, six combat medics, and two aid evacuation specialists. The operational medical officer (battalion surgeon) is the medical advisor to the combat engineer battalion commander and his staff. He is the primary care physician of the battalion. He is responsible for medical treatment provided by the medical platoon. The specific duties of this medical officer are the same as those described in the DIVARTY HHC (refer to paragraph 5-15 a (1)).

b. Section Sergeant. Refer to paragraph 5-15 a (2).

c. Medical Specialists. Refer to paragraph 5-15 a (3).

d. Combat Medics. The duties and functions of combat medics are described in paragraph 5-8.

e. Aid Evacuation Specialist. The duties of the aid evacuation specialist are described in paragraph 5-10.

f. Employment. The medical section establishes a BAS near the engineer battalion and provides unit-level HSS.

(1) The section employs a HMMWV treatment vehicle, a cargo trailer, and two medical equipment sets: one trauma treatment set and one general sick call set.

(2) For communications, the section employs a telephone set (TA 312/PT) and is

deployed in the HHB wire communications net. It also employs an FM tactical radio and is deployed in the net designated by the engineer SOI. This section

also has access to the supporting medical company's tactical operations net to request division-level HSS.

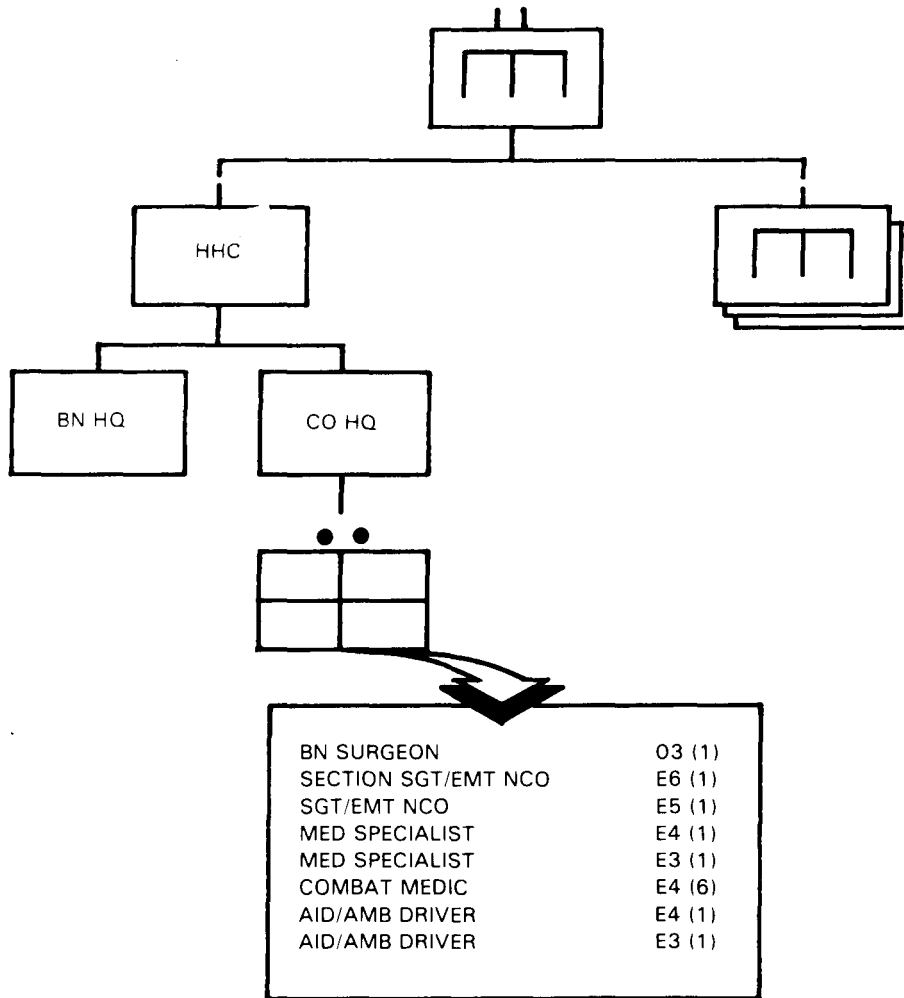

Figure 5-15. Medical platoon, HHC engineer battalion.

Section IV. OPERATING THE MEDICAL PLATOON

5-22. Introduction

a. Responsibilities. The medical platoon leader is responsible for providing quality HSS to the battalion. A medical operations officer, a platoon sergeant, a PA, and combat medics are assigned to help accomplish this mission.

b. Organization and Functions. An effective platoon leader must first understand the organization and functions of the platoon. The

officers basic course and Sections I, II, and III of this chapter explained how it is supposed to work. Now find out how the platoon really works: How is it unique? What are its strengths and weaknesses? It will take time to assess this, but the platoon leader should begin immediately by being observant and asking questions.

c. Structure. Look at the physical plant. How is the garrison BAS laid out? Who has offices and desks? Why? Is there awaiting area for sick call

patients? Is it adequate? Where are patients screened? Where does the PA see patients? Are there exam tables? Does the layout make the best use of the available space? Is the lighting adequate? Where are medical records maintained and are they secure? Where are the sets, kits, and outfits (SKOs) kept? Where are the medical supplies kept? Is the aid station clean? Does it need to be painted?

d. Getting to Know the Platoon.

- How do assigned soldiers interact? Are they cohesive? Who are the informal leaders? Ask the S3 how the platoon performed on the last Army Training Evaluation Plan (ARTEP); how it did at Combat Training Center (CTC); how it performed on other major field training exercises. What does the HHC commander think of the platoon? What does the HHC first sergeant think of it? Are the line company commanders satisfied with the HSS they are receiving? What does the brigade's medical company commander think of the unit? What are the division surgeon's/DMOC's evaluations? Is the battalion commander satisfied with the HSS he is receiving?

- These are just some of the many questions a platoon leader should begin to answer. As he becomes familiar with the platoon, he will find other areas which need attention. The key is to LEARN!

- Mistakes are part of the learning process. A platoon leader should not be afraid to make mistakes; however, the key is to learn from mistakes and not make the same one twice.

e. Personnel. A platoon leader must get to know his platoon members.

(1) *Medical operations officer.* What is the medical operations officer's background? What were his previous assignments? Has he participated in operational planning for employment of medical units? Does he understand tactical operational procedures and maneuvers? Can he organize unit loading plans for best support operations? Does he understand the Army Equipment Maintenance Program? Does he have a working knowledge of general and medical supply operations? How does he get along with other members of the platoon? Does he train personnel in administrative,

maintenance, and logistical procedures? Does he provide tactical training for platoon personnel?

(2) *Platoon sergeant.* What is the platoon sergeant's background? What were his previous assignments? How long has he been in the unit? What is his education level? Is he EMT certified? Does he have the EFMB? What did he score on his last SQT? Is he physically fit? Does he possess a good military appearance? What is his management style? How do the soldiers react to him? How does he see his role? What does he think of his own previous performance? What does he think of the platoon? What does he expect of the platoon leader? How does he see the leader's role? The platoon sergeant-platoon leader relationship is vital, especially knowing, understanding, and trusting one another. If the platoon sergeant is good, learn from him. If he is mediocre, push him. If he is bad, counsel him (document the counseling and coordinate further actions with the HHC commander).

(3) *Physicians' assistant.* Many of the same questions asked of the platoon sergeant should be asked of the PA. Many of the same observations should be made. Additionally, an attempt should be made to evaluate the PA's technical expertise. Does he train the medics? Does he "teach" the medics? How does he handle himself with patients? The brigade surgeon should be asked for his evaluation of the assigned PA; the platoon leader should keep the brigade surgeon informed of his impressions of the PA, positive or negative.

(4) *Combat medics.* Why are they medics? Why are they in the Army? What do they think of the platoon? Do they have EMT/EFMB certifications? Can they read a map? Can they use a radio properly? How did they score on their last SQT? How did they score on their last Army Physical Readiness Test (APRT)? Married? Children? Previous assignments? Age? How is their haircut, uniform, weight? Do they want to stay in the Army? What is their job (in their own words)? How do they like their jobs? Are they satisfied with their own performance? What are their goals?

f. Transportation. Getting to know the vehicles.

(1) *Status.* Does the platoon have all the vehicles it is authorized? If not, why? Do the

vehicles have communications (commo)? Does it work? What is the maintenance status of the vehicles? Are they generally well maintained? (Ask the XO or motor sergeant.) Are the vehicles painted with the appropriate color scheme? Do they have the Geneva emblem?

(2) *Preventive maintenance checks and services.* Have the platoon sergeant teach preventive maintenance checks and services (PMCS) for each of the assigned vehicles using the -10 technical manual standards. Spend a Saturday morning doing this if necessary. Get with the motor sergeant or XO and become familiar with maintenance procedures. Spend time in the motor pool every day. Learn to operate all of the vehicles. The more knowledge the platoon leader has about maintenance in general and the status of each of the assigned vehicles, the better off the platoon will be.

g. Learn Standard Procedures. A platoon leader must familiarize himself with the unit's SOPs; the tactical SOP, administrative-logistics SOP, and maintenance SOP. What additional SOPs does the platoon use; sick call, deployment, maintenance, training, and Medical Proficiency Training Program (MPTP)? Are the SOPs adequate. Are they simple and understandable?

5-23. Garrison Operations

a. Routine Activities. The primary job for soldiers is to be prepared for war. They prepare for war by training, which means frequent field exercises. Field exercises are vitally important; however, the majority of most soldiers' time is spent in garrison. The manner in which routine garrison activities are conducted is indicative of the way soldiers will perform during training exercises and in combat. Run a tight ship in garrison; it will pay big dividends in combat.

b. Battalion Aid Station Administration. Sick call is a daily activity which usually takes place first thing in the morning. It is normally scheduled for 1 hour, starting between 0530 and 0730. There is no standard method of conducting sick call. An aid station should have a sick call SOP which explains the unit's sick call procedures. Review the SOP with the PA and other members of the unit to ensure their satisfaction with it. To improve your

operations, visit other aid stations to see how they conduct sick call. A sequence in which sick call may be conducted is—

- Patient reports to the aid station with a sick slip (DA Form 689) signed by his company commander/representative.

- The patient is met at reception desk; a medic takes the sick slip, and directs the patient to a seat in the waiting area.

- Receptionist "logs patient in" using some type of aid station log book.

- Receptionist pulls patient's health record (HREC) from the file and annotates the date and patient's unit of assignment on a SF 600 (Health Record-Chronological Record of Medical Care).

- Receptionist places a sign-out card (OF 23) in place of the HREC in the file drawer.

- Receptionist places patient's sick slip in HREC folder and gives HREC to medic designated to take vital signs.

- Prior to taking vital signs, medic ensures that the SF 600 is filled out correctly.

- Medic calls for patient by name.

- Medic checks vital signs and records them on the SF 600.

- Medic obtains patient history, performs evaluation, and records the information on SF 600. Medic must sign the entry.

- Physician/PA reviews the record, discusses the case with the medic, and either treats the patient or directs the medic as to proper treatment. Physician/PA makes notes as appropriate and countersigns the SF 600.

- Patient is treated/medications dispensed.

- Patient is returned to duty (RTD), put on quarters, or sent to troop medical clinic (TMC).

- Receptionist “signs patient out” in log book.

NOTE

When physician/PA is not present, medics may use DA Form 5181-R (Screening Notes of Acute Medical Care [LRA]) in accordance with instructions to evaluate patient and countersign notes.

c. Medical Records Administration.

(1) Purpose.

- The HREC is a permanent and continuous file which is begun when a soldier enters the service. The records kept in it are prepared as the member receives medical and dental care or takes part in research.

- The primary purpose of the HREC is to ensure that AMEDD personnel have a concise but complete medical history of everyone on active duty or in a Reserve Component.

(2) Terminal digit filing system.

(a) Medical record folders (DA Form 3444-series) are 10 differently colored folders. The color of the folder represents the last two digits (the primary group) of the patient’s social security number (examples: orange folder—00-09; light green—10-19). Using the terminal digit filing system (TDFS), HRECs are filed with those of like color.

(b) Under the TDFS, the sponsor’s (soldier’s) SSN is divided into three groups. Records are filed using the last two groups; these are the last four digits of the social security number. The last two digits are known as the primary group; the next-to-last two digits are the secondary group. Records are arranged first by their primary group numbers, resulting in folders of like colors being filed together. Within each primary group, the records are arranged in order of their secondary group numbers. Within the secondary group,

records are filed numerically by the first five digits of the SSN.

(3) *Policies and procedures.* Army Regulation 40-66 sets policies and procedures for preparing and using Army medical records. These regulations should be read and kept handy. They provide the “what” and “how to” of medical records administration.

(4) *Inventories and records review.* HRECs should be inventoried monthly for accountability and quarterly for compliance with AR 40-66. When conducting the quarterly review of HRECs, medics should ensure the following criteria are met:

- Medical records jacket is filled out correctly (AR 40-66).

- All forms in the medical record are in correct order as shown in AR 40-66.

- The privacy act statement (DD Form 2005) which is printed on the inside (back) of the DA Form 3444-series jacket is signed and dated as required by AR 40-2.

- A completed SF 88 and SF 93 (as required) are in the medical record and have a physician’s signature (AR 40-501).

- Medical records for personnel with allergies are identified with DA Label 162 and a DD Form 3365 present (AR 40-15).

- Ensure that DA Form 3444-series record jackets are being used for active duty personnel. This includes all temporary/new medical records.

- Immunizations are recorded in the medical record and in the PHS-731 as prescribed in AR 40-66.

- Ensure that immunizations are given to all personnel in accordance with AR 40-562 and as directed by the surgeon.

- Ensure that TB Tine tests have been administered with every periodic physical (AR 40-26).

- Ensure that at least one set of fitted earplugs is in the soldiers' possession upon arrival.
- Ensure that service member's blood type is entered on front of medical record jacket (AR 40-66).
- Determine if personnel who wear glasses need CB mask inserts ordered, or need a new prescription if the last one is over 2 years old?
- Ensure laboratory reports and x-ray report forms are mounted on their respective display sheets.
- Ensure that the medical record jacket has the correct tape coding (AR 40-66).
- Ensure medical records removed from the files are accounted for by use of a signed card (OF 23).
- Records for personnel who PCS (Permanent Change of Station) or ETS (Expiration Term of Service) are logged in the PCS/ETS book.
- Medical record files are screened at least quarterly (AR 40-66).

5-24. Medical Assemblage and Equipment Sets Management

a. Assemblage. Medical assemblage management is not a difficult task. Yet, this is one area in which medical platoon leaders frequently run into trouble. Failure to account for materiel is inexcusable. The best way to prevent accountability problems is to become thoroughly familiar with the property management system and then use it. The medical platoon leader is accountable for the supplies and equipment issued to the platoon. The medical platoon leader has supervisory responsibility for all property; he may be held liable for damage or loss even if he has not signed for any property.

b. Equipment Sets. The medical equipment set (MES), frequently referred to as sets, kits, and outfits (SKO), provides the capability for the

medical platoon to perform its mission. The MES contains the medical supplies and equipment used in providing HSS to the battalion. It is contained in metal chests which are stored in the BAS.

(1) *Types of sets.* There are two types of medical equipment sets: service-unique MES and multi service MES. The set issued to the battalion medical platoon is a service-unique MES. It is managed by the Army Medical Department and consists of medical and nonmedical items under a single stock number. Service-unique MES are identified in Volume I of the Department of Defense (DOD) medical catalog. Revisions to components of the MES are published annually in the supply bulletin (SB) 8-75 series. The supply bulletin revisions constitute authority for updating assemblages.

(2) *Component accountability.* The medical platoon MES (National Stock Number 6545-00-457-6858) consists of expendable, durable, and nonexpendable items. It is important to maintain control of all types of supplies; however, property accounting records of nonexpendable items must be kept. DA Pamphlet 710-2-1 explains procedures to use in maintaining these records.

(3) *Inventory.* Components of the MES are inventoried at least every six months and after each FTX. This is done to maintain accountability and assure readiness. During the inventory, a serviceability inspection is also conducted. Replace obsolete, deteriorated, and outdated items; repair or replace unserviceable items. Ensure that the MES storage area provides adequate security and protection from extreme temperatures.

(4) *Control of medications.*

(a) A DD Form 4998-R (Quality Control and Surveillance Records for TOE Medical Assemblages) is prepared for each dated item of medical supply. Inventory these medications regularly to ensure 100 percent accountability. Check with the DMSO and ask for the local procedures for drug rotation. The DMSO should allow rotation of medications which are nearing their expiration date (example: 90 days from expiration). Effective drug rotation requires management of quality control cards and coordination with the

DMSO. It increases the efficiency of the medical supply system and saves battalion budget dollars.

(b) Controlled medical items (scheduled drugs) may not be stored at the BAS during peacetime. However, a prepared DA Form 2765-1 (Request for Issue or Turn-in), less document number, with an 06/05 priority designator for required medications (code R&Q items) is maintained. The DMSO will fill these requests upon notification of the unit's deployment.

(c) Expired stocks of medical supplies and items determined to be unsafe or unsuitable for use will be destroyed in accordance with AR 40-61. Destruction is normally accomplished at the DMSO, not the BAS; usually on a monthly basis and requires a DA Form 3161 (Request for Issue or Turn-in) from the supported unit.

5-25. The Division Medical Supply System

a. Health Services Materiel Officer. The HSMO is a special staff officer who provides medical logistical support to the division. This support is in the form of both medical supply and maintenance of medical equipment. The HSMO also provides advice and assistance on matters pertaining to medical materiel. The HSMO is a member of the division medical supply section of the MSMC.

b. Mission. In peacetime, the DMSO resupplies the DISCOM medical companies and the division medical platoons using supply point distribution. (This means supported units pick up supplies from the supply point.) The Class VIII supply point (DMSO warehouse) is normally located in the MSMC's AO. Each supported unit has a supply account with the DMSO. Routine supply requests come from the supported unit directly to the DMSO. However, requests for nonexpendable items must go through the requestor's unit property book officer (PBO). Refer to the battalion SOP for specific procedures.

c. Receipt for Supplies. To establish a Class VIII supply account, the supported unit must provide the DMSO a DA Form 1687 (Notice of Delegation of Authority-Receipt for Supplies). The DA Form 1687 is prepared in accordance with AR

710-2 and AR 40-61. A new DA Form 1687 must be submitted upon change of approving authority; upon the addition or deletion of a designated individual; or at a minimum, every 12 months. Only those individuals designated on the DA Form 1687 are authorized to receipt for medical supplies.

d. Request Document. The DA Form 2765-1 is used to request medical supplies. Information needed to complete this form can be found in the Army Master Data File (AMDF). The original completed DA Form 2765-1 should be given to the PBO/DMSO. The BAS should retain the third copy (flimsy) of the DA Form 2765-1 in a due-in status file.

e. Durable Items. Request for durable items of medical supply are handled in much the same way. Some additional documentation, such as a memorandum explaining why the item is needed, is normally required for durable items. Request for durable medical items are sent from the unit supply room to the DMMC. Upon receipt of the item, the DMMC notifies the unit supply room and a designated individual from the unit receipts for the item. The item is then placed on the unit's property book (hand receipt) and issued to the medical platoon.

f. Document Register. The BAS must maintain a DA Form 2064 (Document Register) which lists all medical supply transactions. The document register should be kept in accordance with DA Pam 710-2-1 and should be reconciled monthly. The DMSO can provide assistance in establishing or reconciling the document register.

g. Priority Designator System. In medical supply, a priority designator system is used to establish priority for requested supplies. The priority designators authorized for use are the same as used in requesting other classes of supplies. Priority designators and their uses are—

- 13 (12 in USAREUR and some CONUS units) —this number is used for all normal supply transactions.

- 06 (05 in USAREUR and some CONUS units) —this number is used for items which, by their absence, cause a unit's mission to be

impaired. The DMSO will attempt to immediately fill an 06/05 request. The company commander of the requesting unit must sign the back of the DA Form 2765-1 for 06/05 requests.

- **03 (02 in USAREUR and some CONUS units)** —this is the highest priority available for medical supplies and denotes a life or limb emergency. Supply requests with an 03/02 priority must be signed by a physician and authenticated by the battalion commander of the requesting unit. The DMSO will immediately fill an 03/02 request. If the item is not available, the DMSO stops all other activity and uses every available means to secure the needed item. Thousands of dollars may be expended to get the high priority item to the location in which it is needed by the most rapid means; therefore, ensure that the correct priority designator is used on a supply request.

h. Excess Materiel. It is important that units not maintain more medical supplies than they are authorized. However, situations arise where a unit acquires excess supplies. Turn in these supplies to the DMSO using a DA Form 2765-1. Check with the DMSO for local policies governing the turn-in of excess medical materiel.

5-26. Immunizations

a. Responsibility. Commanders are responsible for assuring that all unit personnel receive required immunizations and that records of such immunizations are maintained.

b. Immunization Records. Soldiers are issued PHS Form 731 (International Certification of Vaccination, II Personal Health History) when they receive initial immunizations upon entering the military service. At the same time, a SF 601 (Immunization Record) is initiated and placed in the soldier's health record. These forms are compared for accuracy when the soldier in processes to a new unit. If the soldier requires immunizations, refer him to the supporting TMC or hospital.

c. Administering Immunizations. On occasion, immunizations may be given at the BAS, such as flu shots. When this is done, a "member of the medical department/service trained and qualified in emergency resuscitative techniques" (this normally means a physician or PA) must be

present. An emergency tray (shock tray) must also be on hand for immediate treatment of serious reactions. Personnel administering immunizations must be trained in immunization procedures. A list of personnel authorized to administer immunizations should be maintained at the BAS. When planning to give immunizations at the BAS, coordinate with the supporting TMC and brigade/division surgeon.

d. Status of Personnel. The BAS maintains an immunization status composite record of all personnel in the unit. AR 40-66 and DA Pam 600-8 require that this record be inspected by the unit commander at specific intervals.

5-27. Maintenance

a. Maintenance Program. An effective maintenance program is essential to ensure a unit's ability to perform its mission. The most important element in a unit maintenance program is the equipment operator. He must be familiar with his equipment and able to maintain it. Leaders ensure that operators are trained in equipment maintenance procedures.

b. Procedures. This section represents a basic overview of maintenance procedures. Use it as a starting point from which to learn maintenance and maintenance management procedures. To learn what you need to know requires that you "learn by doing."

c. Levels of Maintenance. Maintenance operations are divided into three levels (unit, intermediate, and depot) to efficiently coordinate them with other military operations.

- **Unit maintenance.** Unit maintenance is similar to the maintenance applied to privately - owned vehicles. It focuses primarily on minor repairs, adjustments, and replacing minor components, such as starters, generators, brakes, and spark plugs. The equipment operator/crew with the aid of unit mechanics perform unit maintenance. This is the level of maintenance with which a platoon leader is primarily involved.

- **Intermediate maintenance.** The intermediate level of maintenance has two

orientations, direct support (DS) and general support (GS).

- **Direct support maintenance units** perform repair and return to the user functions. They are organic to the division and focus on far forward support. Direct support maintenance units perform repair work beyond the capability of unit maintenance.

- **General support maintenance units** perform major repairs and overhauls. Items repaired at the GS level are returned to the supply system. General support maintenance does not perform a repair and return to the user function.

- **Depot maintenance.** Depot maintenance is performed at fixed facilities in CONUS and major overseas areas. Depot maintenance is characterized by overhaul and rebuild functions.

d. Maintenance Terms and Functions. To understand maintenance, a platoon leader must first become familiar with terms used to describe various maintenance functions.

- **Prescribed load list.** A prescribed load list (PLL) is the unit's repair parts stockage. It is composed of an authorized stockage list (ASL) which is a list of parts prescribed for a unit; also demand supported and command supported items. Demand supported items are parts for which sufficient need has been historically established to justify their stockage. Command supported items are parts which the unit commander has directed be stocked.

- **Preventive maintenance checks and services.** Preventive maintenance checks and services (PMCS) consist of periodic checks (before, during, and after operations; daily, weekly, monthly) and scheduled services (Q-services). The operator's technical manual (-10) for each item of equipment lists the PMCS to be conducted and their frequency.

- **Cannibalization.** Authorized removal of serviceable parts from unrepairable equipment by maintenance units.

- **Controlled exchange.** Removal of serviceable parts from unserviceable but repairable

equipment to bring a like piece of equipment to operational status. This requires command authorization.

- **Technical manuals.** Technical manuals (TMs) provide technical information (operator instructions, repair procedures, and repair parts) about specific pieces of equipment. Technical manuals are referred to as -10s (operator's manual), -20s (unit and DS maintenance manuals), -30 (DS/GS manuals), -40 (GS and depot manuals), and -14 (applies to all levels).

e. Battle Damage Assessment and Repair. Battle damage assessment and repair (BDAR) techniques expedite return of a damaged piece of equipment to the current battle.

- Battle damage assessment is used to determine the extent of damage to equipment. Equipment is classified according to the type of repair needed; plans are made for repair of each item. Priorities for repair of battle damaged items are usually—

- Most essential to the immediate mission.

- Repairable in the least time.

- Repairable but not in time for the immediate mission.

- Battle damage repair involves use of emergency repair techniques to return a system to a mission capability. Normally BDAR is only used in combat at the direction of the commander. It includes—

- Shortcuts in parts removal or installation.

- Modifying components from other items.

- Using parts from a noncritical function elsewhere on an item to restore a critical function.

- Bypassing noncritical components to restore basic function capability.

- Cannibalization.

- Making parts from kits or available material.
- Using substitute fuels, fluids, or lubricants.
- The BDAR program is not to be used in the repair of medical equipment. Only medical equipment repair personnel are adequately trained to effect the type of temporary fixes associated with this concept. Due to the delicate, technological complex nature of most medical equipment, temporary fixes even by a medical equipment repairer is discouraged.

5-28. Maintenance Forms and Records

Numerous forms and records are used to document maintenance activities. These records are maintained for historical purposes, to ensure necessary services are performed, and to establish requirements for repair parts stockage.

a. Dispatch. DD Form 1970 (Motor Equipment Utilization Record) is commonly referred to as a "dispatch." It is issued to the vehicle operator by the unit maintenance clerk before the vehicle is used.

b. Inspection and Maintenance Worksheet. DA Form 2404 (Equipment Inspection and Maintenance Worksheet) is the "bread and butter" form of unit level maintenance (see TM 38-750). The operator uses this form to record faults that he cannot correct. Unit maintenance personnel refer to the form to identify necessary repairs and annotate corrective actions. It is used when conducting scheduled service and during other technical inspections. The DA Form 2404 is quite versatile and is the most frequently used form in the motor pool.

c. Maintenance Request. DA Form 2407 (Maintenance Request) is used by unit maintenance personnel as a request to support units (DS) for repair work.

d. Lubrication Order. Lubrication order (LO) is more like a technical manual than a maintenance form. It details how to lubricate the vehicle, the types of lubricants to use, intervals to

be observed, and special precautions. An LO should be kept on each vehicle with the appropriate TM.

5-29. Unit Maintenance Organization

a. Battalion Maintenance Assets. The battalion's maintenance assets (unit - level maintenance) are organized somewhat similar to its medical assets. All maintenance assets are organic to the battalion maintenance platoon. They are apportioned out to support the various companies.

b. Company Maintenance Section. Within the company maintenance section, the key players are the battalion motor sergeant, normally an E-8, and the motor officer, usually the company XO. The motor sergeant allocates jobs to his mechanics and supervises their activities. He also runs the motor pool shop office. The motor officer is responsible to the company commander for the unit's maintenance status.

c. Battalion Maintenance Platoon. The battalion maintenance platoon is run by the battalion motor officer (BMO). The battalion motor sergeant, an E-8, and the battalion maintenance technician, a warrant officer, assist the BMO. The battalion maintenance technician is the technical expert in the field of maintenance. He frequently interfaces with DS maintenance and maintenance support teams.

5-30. Training

a. Importance. "The more you sweat in training, the less you bleed in war." This ancient Chinese proverb expresses the importance of training very simply and accurately. Much more has been said and written about training, the bottom line of which is that to be prepared for war, we must train. Leaders have an obligation to ensure that effective training takes place in the unit. For training procedures, see Appendix A.

b. How to Train. Army training management can be a difficult task, particularly for a new platoon leader. Do not expect to become an immediate expert. Study the system read Army training literature (AR 350-1, 25-series field manuals, 8-series field manuals, local policies,

regulations, and SOPs); talk with supervisors; and learn from NCOs.

c. Get Involved in Training. The importance of a leader's involvement in training cannot be overemphasized. Officers and NCOs do not only plan and present training, they also participate. Leader participation motivates soldiers; it emphasizes the importance of the training event. As a participant, the leader can evaluate the quality of the training being presented. Participating in training allows officers and NCOs to brush-up on their skills and, in many cases, to develop new skills.

d. Training Responsibilities. Unit training consists of individual and collective training. Individual training is conducted for tasks which the soldier must be able to complete unassisted, such as applying a pressure dressing. Individual training develops the technical proficiency of the soldier. Collective training builds on individual skills and provides the basis for unit proficiency in executing its missions, such as establishing an aid station and providing HSS in a mass casualty situation. Generally, officers are responsible for collective training and NCOs are responsible for individual training.

e. Battle Focus. The unit's wartime missions are the source from which all training activities are derived. This is known as battle focus. A successful training program is achievable by narrowing the focus to vital tasks that are mission essential. This is accomplished through the development of a mission essential task list (METL).

f. Mission Essential Task List Development.

- The commander of each unit in the Army from corps to company level must develop a METL. The medical platoon, being a unique organization in a combat arms battalion, should also develop a METL. This is done by first considering the battalion's mission and reviewing the battalion METL. The medical platoon METL must support the battalion METL. The next step is to get a copy of the FSMC's METL and discuss it with the FSMC commander. The medical platoon METL must be coordinated with the FSMC METL. Other sources to consider are SOPs; emergency deployment

readiness exercise (EDRE) plans; and division surgeon and DMOC plans and policies. The final step is to present the medical platoon METL (which should consist of roughly a half-dozen tasks) to the battalion commander. Once the battalion commander approves the METL, it becomes the source document for developing the medical platoon training plans. It should be changed only when the unit's mission changes.

- Involve the PA, medical operations officer, platoon sergeant, and other platoon members in the METL development process. This creates a common understanding of the unit's critical wartime requirements; it is essential in developing the platoon training plans.

- A condition statement and standards list for each mission essential task is developed. The resulting training objective provides a clear list of expected training performance. The platoon sergeant will take the METL and develop a supporting individual task list for each mission essential task. Some documents which will assist in developing these collective and individual tasks are—

- Mission training plans.
- Soldiers training publications.
- Deployment or mobilization plans.
- General defense plan.
- Army, MACOM, and local regulations.
- Local SOPs.

g. Planning.

(1) *Needs assessment.* The first step in planning for training is the assessment. Assess current training proficiency by reviewing training evaluations, such as CTC take-home packages, FTX after-action reports, and inspection results. Also consider recent or projected personnel turnover or new equipment fielding. Finally, ask subordinates for their opinions and consider your own observations and impressions. Rate each task "T"

(trained), “P” (needs practice), “U” (untrained), or “?” (unknown). The training requirements are simply the training necessary to achieve and sustain the desired levels of proficiency for each mission essential task.

(2) *Training strategy.* With the assistance of platoon members, develop a strategy to accomplish each training requirement. This should include plans to improve proficiency in some tasks and sustain proficiency in others. The training strategy establishes priorities by indicating the frequency each mission essential task will be performed during the training period. The strategy includes guidance that links METL with training events (coordinate training with the HHB/HHC/HHT/HHS commanders, S3 and, if necessary, battalion commander).

h. Planning Calendars.

(1) *Battalion training schedules.* The battalion produces long-range, short-range, and near-term training schedules covering 1 year, 3 months, and 1 week respectively. The weekly training schedules are normally provided for each company. The medical platoon should get a copy of these schedules.

(2) *Medical platoon input.* The medical platoon should hold regular training meetings of key leaders within the platoon to develop medical platoon input to the battalion’s training schedules. Before the long-range training schedule is prepared, the medical platoon leader should tell the HHC commander, in general terms, what training the medical platoon needs during the upcoming year. Upon receipt of the long-range training calendar, the medical platoon should meet and refine plans for training in the first quarter. The medical platoon leader then provides specific information to the HHC commander for inclusion in the battalion quarterly training schedule. The medical platoon then holds weekly training meetings to—

- Review training conducted during the previous week.
- Discuss training planned for the current week.
- Make firm coordination for training scheduled for the upcoming week.

Provide final details of medical platoon training plans for the upcoming week for inclusion in the weekly HHC training schedule.

(3) *Coordinating medical platoon training.* Remember, all medical platoon training must be conducted within the parameters established by the battalion/company training schedule. For example, the battalion training schedule calls for a FTX with a company force-on-force exercise; perhaps the medical platoon can conduct an evacuation exercise concurrently. This requires coordination with the S3, company commander, and possibly the FSMC commander and others. Most of all, conforming medical platoon training plans and activities to the parent unit activities require creativity, flexibility, and initiative on the part of the medical platoon leader. Training must be conducted without detracting from the HSS being provided the companies undergoing training.

i. Expert Field Medical Badge.

(1) *The program.* The Expert Field Medical Badge (EFMB) program has received high level attention in recent years. In many units, the medical platoon leader’s evaluation is directly tied to the percentage of his platoon which passed the EFMB test. In some divisions, awards are given to the battalion with the highest EFMB pass rate. Aside from these facts, the EFMB is an excellent program and is a good measure of training success and unit motivation. If planned and administered correctly, EFMB training can tie directly into your platoons METL-based training program.

(2) *Training and test management.* EFMB training is managed differently at various posts around the Army. Some provide centralized EFMB training, while others leave it to the unit. In most divisions, EFMB training is conducted in the unit with some type of centralized training for all division EFMB candidates. EFMB testing is standardized; however, the frequency of testing may vary. For additional information on EFMB training and testing, see TC 8-100.

(3) *Command.* The medical platoon leader should find out how much emphasis the battalion commander places on the EFMB and plan training accordingly. Call the division surgeon or

DMOC to get details of local EFMB training and testing procedures.

j. Army Medical Department Systematic Modular Approach to Realistic Training. The Army Medical Department Systematic Modular Approach to Realistic Training (ASMA) was created to provide hospital-based clinical skills training and development to medical personnel. The program allows an established number of medics from each unit to rotate through the hospital at set intervals.

Normally, medics will be enrolled in ASMA for a period of 90-180 days. The ASMA offers an excellent opportunity for medical personnel to sharpen their clinical skills through work in the emergency room or in a hospital ward or clinic. However, the program must be closely monitored to ensure that the participants are receiving good training. If, as medical platoon leader, you are not satisfied with the training being provided through the ASMA, discuss your concerns with the division surgeon and/or hospital commander.

Section V. EMPLOYMENT OF THE MEDICAL PLATOON

5-31. Planning and the Health Service Support Plan

a. Planning. To ensure that HSS is responsive to the battalion (squadron), the medical platoon leader or the medical operations officer must attend all operational briefings and planning sessions. They are responsible for providing the HSS portion of battalion SOPs, OPLANs, and operation orders (OPORDs). The HSS planned for tactical operations is addressed in the administrative and logistics annex of the battalion OPORD. It should include—

- Location of forward treatment sites.
- Ground and air medical evacuation routes, ambulance exchange points, and far forward patient collecting points.
- Location of the supporting DCS (medical company).

b. Health Service Support Plan. The health service support plan (HSSPLAN) must be responsive and support the maneuver commander's intent. The HSSPLAN is best disseminated through the use of an overlay showing preplanned treatment team/BAS locations and ambulance exchange points. The HSSPLAN is keyed to the maneuver battalion's OPORD. Once approved, the overlay is distributed to maneuver company commanders, elements of the medical platoon, the tactical operations center, and the ambulance platoon leader of the supporting FSMC. A sample overlay (HSSPLAN) depicting preplanned positions for ALFA and BRAVO treatment teams of a BAS and AXP of a FSMC ambulance platoon is shown in Figure 5-16. To effectively execute the HSSPLAN, the medical operations officer monitors the tactical situation. He maneuvers the treatment teams and coordinates changes for AXP locations based on the progress of the battle. This allows the HSS system to rapidly clear the battlefield of casualties; to treat patients early; and to return minimally injured soldiers to the fight.

NOTE

The battalion surgeon and the medical operations officer must keep the medical platoon personnel informed of the tactical situation.

5-32. Combat Medic

a. Allocation. As was mentioned previously, combat medics are allocated to mechanized infantry on the basis of one medic per platoon and a senior medic for each company. In armor units, the allocation is one medic per company. Normally, one ambulance team is positioned in the company area.

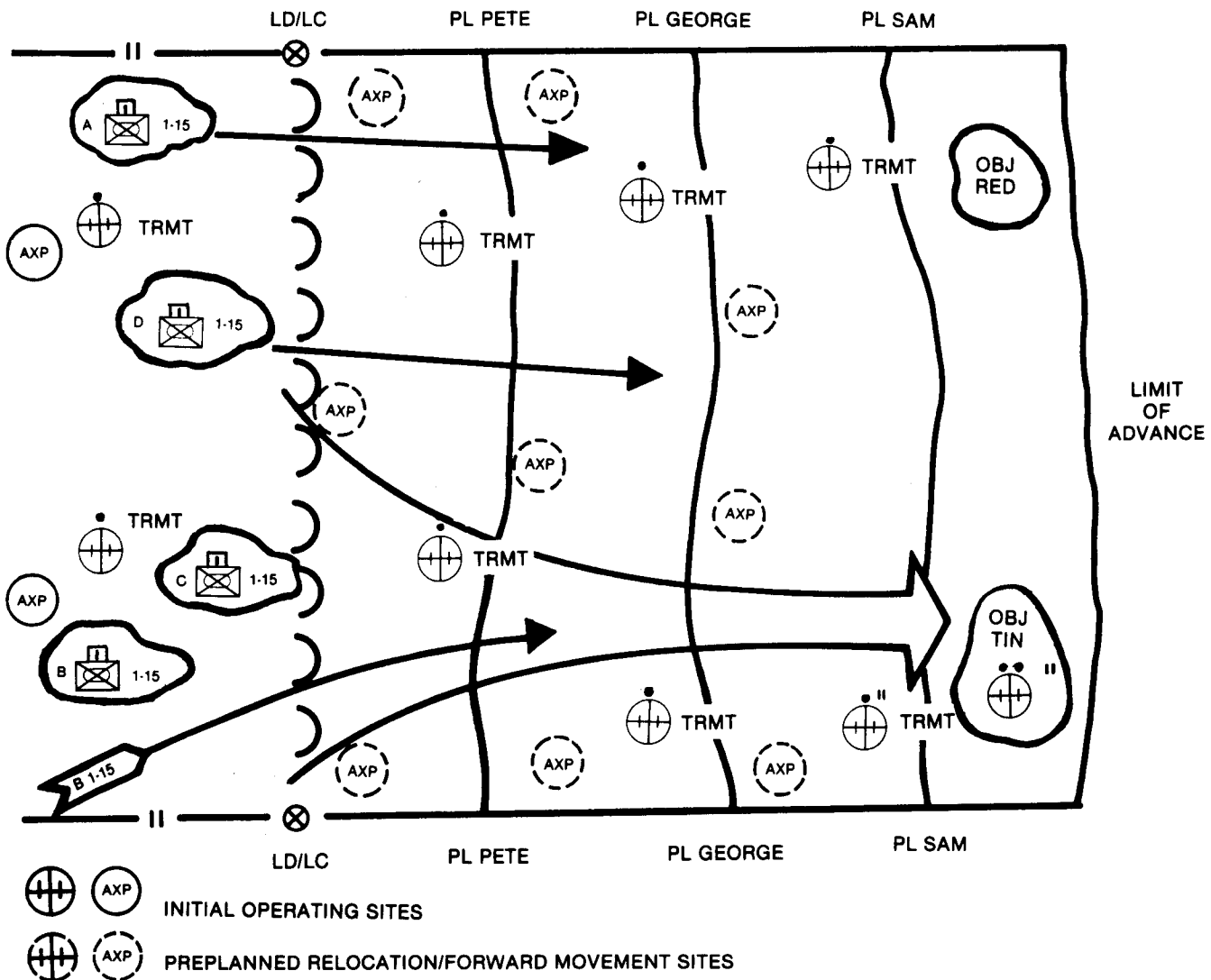

Figure 5-16. Preplanned position of treatment teams and ambulance exchange points.

b. Platoon Medic Location. The platoon combat medic normally locates with, or near, the element leader. When the platoon is moving on foot in the platoon column formation, he positions himself near the element leader trailing the base squad forward of the second team (Figure 5-17). This formation is the platoon's primary movement formation. When the platoon is mounted, the combat medic will normally ride in the same vehicle as the platoon sergeant (Figure 5-18). The combat medic will provide care to the occupants of his vehicle. He will not be able to treat occupants of other vehicles while the platoon is moving or engaged.

c. Company Medic. The company combat medic normally collocates with the first sergeant. When the company is engaged, the combat medic will remain with the first sergeant and provide medical advice as necessary. As the tactical situation allows, he will provide medical treatment and prepare patients for evacuation. The combat medics assigned to the company's evacuation vehicle work with the company medic in a coordinated effort. When a casualty occurs in a tank or an armed fighting vehicle, the aid/evacuation team will move as close to the armored vehicle as possible, making full use of cover, concealment, and defilade. Assisted, if possible, by the vehicle's crew,

they will extract the casualty from the vehicle and administer emergency medical treatment. The aid/evacuation team moves the patient to the treatment squad/BAS or to a collecting point to await further

evacuation. The company medic normally remains with the company command post, but may be used anywhere in the company, assisting the aid/evacuation teams in some situations.

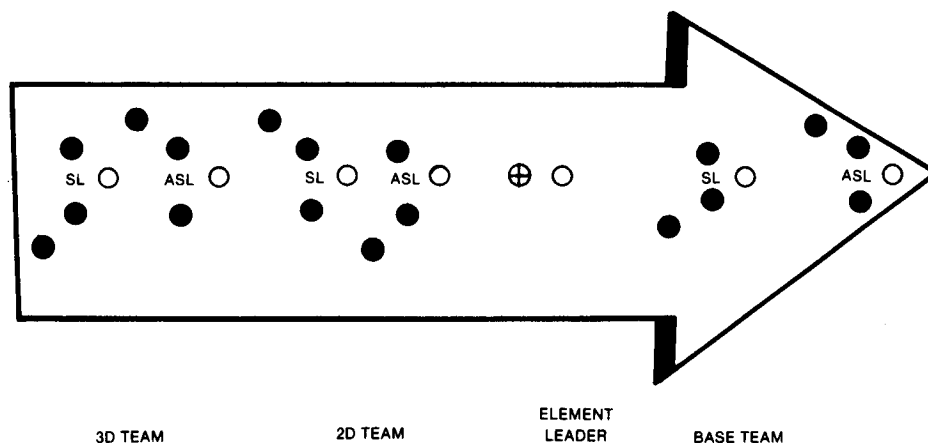

Figure 15-17. Dismounted platoon.

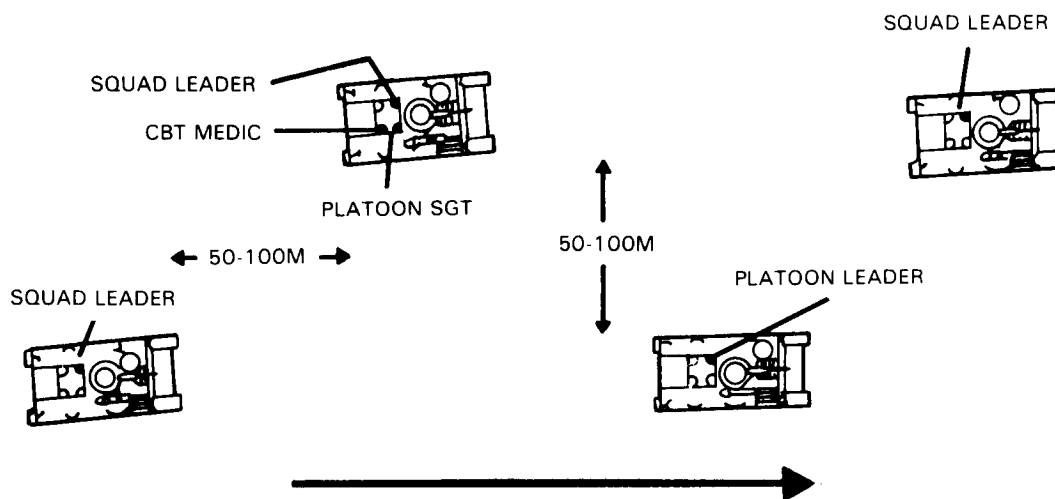

Figure 5-18. Mounted column.

5-33. Combat Lifesavers

Combat lifesavers are nonmedical unit members who have received additional training to increase their skills beyond basic first aid procedures. The primary duty of the CLS does not change. He is a fighter first and medic second. The CLS medical duties are performed when the situation permits. The CLS carries a CLS's medical equipment set and

receives his medical supplies (resupply) through his unit supply section. For CLS training material and equipment, see Appendix B.

5-34. Preparation for Tactical Operations

a. *Planning.* The lack of adequate planning on the part of medical platoon leaders and FSMC

commanders has been repeatedly noted at the National Training Center.

b. Tailoring Medical Platoon Organization to Mission. The platoon organization best suited for specific combat operations are discussed in Sections II and III of this chapter. However, it is important to realize that although the medical platoon is authorized a certain number of personnel and amount of equipment with which to accomplish its mission, on-hand figures seldom match those authorized. The ability to accomplish the mission with less personnel and equipment than authorized is one of the greatest challenges which leaders face Armywide.

c. Reconnaissance. All key personnel within the medical platoon, especially evacuation NCOs, conduct personnel through reconnaissance before and between phases of an operation. If an on-site reconnaissance is not possible, a map recon is conducted. During the map recon, primary and secondary evacuation routes through each company's sector are designated. Prepare an overlay displaying evacuation routes, BAS locations at various points in the operation, and if possible, the FSMC location. In developing the HSS overlay, use phase lines designated for the maneuver elements. Key BAS relocation upon maneuver units crossing certain phase lines. Refer to FM 101-5-1, Operational Terms and Symbols, for correct overlay symbols and techniques. Distribute a completed overlay to each company commander, the S3, the FSMC commander, and ensure that senior company medics and evacuation NCOs have copies.

d. Medical Platoon Operations Order. As the map recon is conducted, also develop the medical platoon OPORD. The medical platoon OPORD must be tied to the parent battalion OPORD and should be coordinated with the FSMC. It may be written or oral, but must use the five paragraph OPORD format. Prior to the operation, issue this order to members of the medical platoon and attached/supporting medical personnel.

5-35. Deployment

a. Complexity of Deployment. Field operations begin with a deployment. This may be as simple as loading vehicles and convoying to a

training area on-post, or as complicated as loading the entire unit for an overseas deployment.

b. Movement Plans. The key to a successful deployment is accurate movement plans. Each company should have a movement officer responsible for maintaining a unit movement file. This file contains detailed information on the unit's capability to deploy. It specifies transportation requirements necessary to support the unit's movement by various modes of travel, such as air, rail, or convoy. Among the most basic and most important information assembled by the unit movement officer is a list of prime movers (trucks designated to move trailers) and their designated trailers, and load plans for each vehicle.

c. Medical Platoon Loading Plans. The medical platoon must be able to move all of its personnel (less company and platoon medics) and equipment to the field with its organic vehicles. The platoon's load plans prescribe the method by which this is done. The load plan specifies exactly what supplies and equipment will be carried on which vehicle. It specifies a prime mover for each trailer. The MES, BAS is divided between the platoon's aid station vehicles to give each treatment team equal capability. The load plan allows for personal baggage, tentage, camouflage nets and poles, heaters/stoves, tools, and any other miscellaneous supplies and equipment. See Appendix D for an example.

d. Evaluate Load Plan. The platoon load plan must be accurate and workable. The only way to be sure load plans are valid is to test them. Periodically, the medical platoon should load-out all of its supplies and equipment in accordance with the platoon load plan (FTX deployments are good opportunities to do this). This will reveal any shortcomings in the load plans and will result in more workable loading arrangements. Any changes made during these practice load-outs should be reported to the company movement officer. Once an efficient load plan is developed for each vehicle, it is published so that the crew becomes familiar with the configuration. Before deployment, inspect each vehicle to ensure its configuration matches the load plan.

e. Convoy. The final step in the deployment process is normally a convoy to the maneuver area.

The convoy will most likely be conducted as a tactical road march consisting of several march units dispersed over various routes. The battalion tactical SOP prescribes convoy procedures; it includes intervals between vehicles, speed, rest halt intervals, safety briefings, and night and blackout drive procedures. Convoys are relatively simple operations but require much coordination, close control, and active attentive participation by drivers.

5-36. Establishing the Battalion Aid Station/Company Aid Post

a. Site Selection. Prior to deployment, an initial site for the BAS is designated as well as future sites to be used as the operation progresses. This is done during the map recon, is coordinated with other staff members, and is published in the battalion's OPOD and the HSS overlay. An example of a BAS arrangement is depicted in Figures 5-4 and 5-5. Some factors to consider when selecting a site for the BAS include—

- *Cover and concealment.* The area selected should provide maximum cover and concealment without hampering mission or communications. Overhead cover is desirable for protection from biological/chemical contamination, if attacked.

- *Accessibility.* The site should provide adequate access to all approach and evacuation routes.

- *Space.* The site should have adequate space for the unit's operation and expeditious loading and unloading patients, supplies, and equipment.

- *Drainage.* The site should provide good drainage during inclement weather.

- *Decontamination area.* The area should be large enough to provide an area for patient decontamination, if required.

- *Landing site.* Provide an area for a helicopter landing site.

- *Security.* The site should provide security and be defensible.

- *Communications.* When considering all factors of site selection, remember that terrain can impede FM communication systems.

NOTE

If the BAS is collocated with the combat trains or if another staff member selects the BAS site, the medical platoon leader must ensure the above factors are considered.

b. Establish Battalion Aid Station. When the BAS elements arrive at the operational site, the following actions are taken:

- An advance party is on location and has the area secured.

- Move BAS vehicles into position (covered and concealed, if possible).

- Establish perimeter security, if necessary.

- Configure supplies and equipment into tailgate medicine operational posture.

- Establish helicopter landing site and equipment to support patient care.

- Report to the main CP, combat trains CP, and FSMC that the BAS is operational.

- Make radio check with each company senior medic.

- Erect extension/tentage. An example of a M577 extension configured as a BAS (treatment station) is depicted in Figure 5-19.

- Erect camouflage nets.

- Operators perform after operation check of vehicles.

- Complete final preparation to receive patients, incorporate sleep/work schedule to ensure radios are continuously monitored.

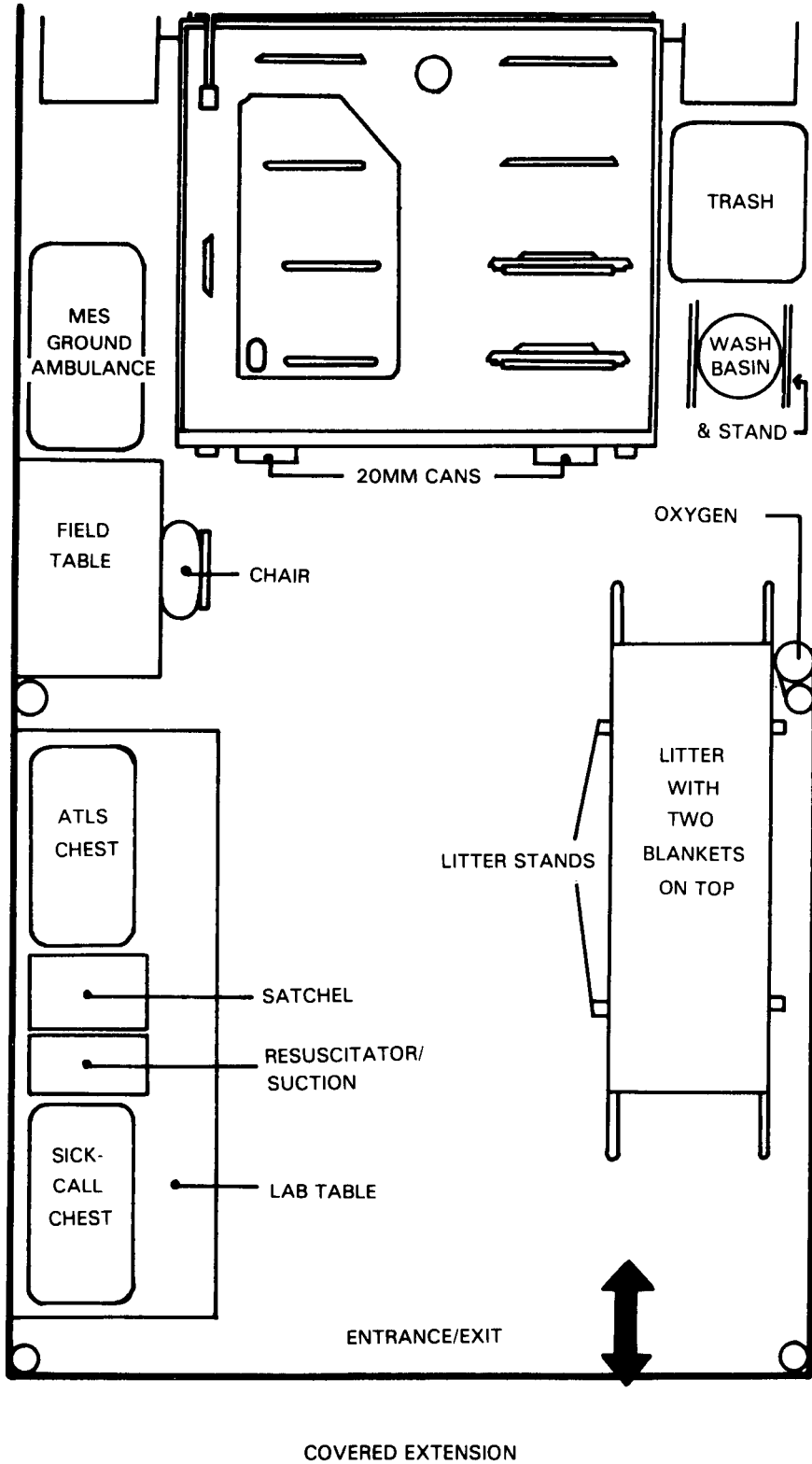

Figure 5-19. M577 configured as a BAS.

c. Establish Company Aid Post. When establishing a company aid post, take the following actions:

- Company medic remains with or near first sergeant; this is his transportation.
- If possible, collocate aid post with medical evacuation vehicle (company medic must not depend upon this vehicle for his transportation). The company medic must remain with the company.
- Prepare area to receive patients.
- Make radio check with platoon medics, if possible.
- Camouflage as necessary.

5-37. Treat and Evacuate Patients

a. Combat Medic Care. When casualties occur, first aid will usually be rendered by buddy aid or perhaps CLS care. The platoon medic/company medic will then go to the casualty's location or the casualty will be brought to the medic. The combat medic makes his assessment; administers initial medical care; initiates a DD Form 1380 (Field Medical Card); then requests evacuation or returns the individual to duty. A vehicle from the evacuation section (usually pre-positioned forward) picks-up the patient and transports him to the BAS.

b. Battalion Aid Station Care. When the patient arrives at the BAS, initially he is taken to a triage point. When the treatment teams are collocated, the PA usually performs triage (if the treatment teams are separated or a mass casualty situation exists, an EMT NCO performs triage). The patient is categorized as immediate, delayed, minimal, or expectant. Depending upon his triage category and the patient load, the patient is then taken to either the patient holding area or the treatment area. Ultimately, medical treatment is administered and the patient is either evacuated to the DCS or returned to duty.

c. Mass Casualty Situation. Keep in mind that the type of operation being supported will to a great extent determine the rate of casualties generated. In a high-intensity conflict, mass

casualty situations will develop. Medical treatment and evacuation capabilities may be temporarily overwhelmed. Self/buddy aid and CLS care will be critical. Nonmedical vehicles may be required to evacuate casualties (FM 8-10-6). It is possible that a decision will have to be made to abandon patients; however, if patients have to be abandoned, a medic with medical supplies must remain with them. In any scenario, the guiding principle is to provide the greatest good for the greatest number of patients.

5-38. Disestablish a Field Medical Treatment Facility

When a unit receives orders to relocate, load vehicles according to loading plans in order to provide HSS while en route or at the relocation site. All potential sources of intelligence which could be used by enemy forces are removed before leaving the area. All wires that were used for communications are recovered and serviced. Prior to departing, all personnel are briefed on the move and issued strip maps. Patients awaiting evacuation are moved with the BAS, if possible. The BAS must maintain communications and continue to monitor the battle.

5-39. Field Sanitation

a. Medical Threat. Poor field hygiene and sanitary practices pose a very real threat to units both in training and combat. In fact, throughout recorded history, DNBI have accounted for a higher percentage of casualties than have battle injuries. (In US history, this ratio is three to one.) Even today, outbreaks of diarrheal disease, food poisonings, arthropod bites, and environmental injuries (heat and cold) account for significant training time loss. Although the medical threat consists of hundreds of casualty-producing injuries and illnesses, the causes can be, reduced to six primary categories.

- Heat injuries caused by combinations of heat stress and insufficient water consumption.
- Cold injuries caused by combinations of inadequate clothing, low temperatures, wind, and wetness.

- Diseases caused by biting arthropods.

- Diarrheal diseases caused by drinking impure water, eating contaminated foods, or not practicing good individual and unit PVNTMED measures.

- Diseases, trauma, or injuries caused by physical or mental unfitness.

- Environmental or occupational injuries caused by carbon monoxide, noise, blast overpressure, and solvents.

b. Preventive Medicine Measures. The medical platoon leader is responsible for monitoring the health of the soldiers in his battalion. He can be proactive in this regard by ensuring the provision of the following PVNTMED measures.

- Large amounts of water to combat the threat of heat injury. Joint planning factors indicate that as much as 20 gallons per person per day will be required during operations in hot weather environments.

- Adequate changes of socks and clothing to prevent cold injuries caused by wet clothing.

- Arthropod repellents, aerosol insecticide, bed nets, and louse powder for the individual; pesticides and associated equipment for field sanitation teams; and PVNTMED units support to prevent arthropod-borne disease.

- Iodine tablets and calcium hypochlorite to maintain water potability.

- Adequate fresh air ventilation in confined vehicles and in maintenance and sleeping areas. Proper ventilation prevents carbon monoxide poisoning.

- Adequate hearing protection.

- Adequate vision protection to prevent traumatic eye injury from laser devices, sighting devices, and secondary projectiles.

(1) *Individual protective measures.*

The mobility and dispersion of modern fighting forces require that individual soldiers take actions to protect themselves against the medical threat. These simple individual actions are called PVNTMED measures. Applying these measures can significantly reduce the time loss due to DNBI. The soldier should—

- Protect himself against heat by—

- Drinking plenty of water.

- Using the correct work/rest cycle as directed by his leader.

- Eating all meals to replace salt.

- Recognizing the risk associated with wearing mission-oriented protection posture (MOPP) clothing, body armor, or when inside armored vehicles.

- Modifying his uniform as directed/authorized by his leader.

- Protect himself against the cold by—

- Drinking plenty of water to replace loss of fluids during periods of strenuous exercise.

- Wearing his uniform properly in loose layers to hold maximum body heat.

- Washing his feet daily and keeping them dry by changing socks several times a day.

- Keeping his body warm by exercising his trunk and limbs whenever possible. Exercising his feet, hands, and face to increase circulation.

- Protect himself against biting arthropods by—

- Using his uniform as a barrier.

- Using arthropod/insect repellent.

or tablets as prescribed.

aerosol insecticide at night.

uniform clean.

diarrhea by—

drink, or ice approved by medical authorities.

available. When not available, treating water by using iodine tablets or chlorine ampules, or boiling it.

fitness by—

infections.

disease.

urinary tract infections (drinking plenty of water).

stress.

ventilation while in closed spaces such as when firing weapons from inside an armored vehicle.

- Taking antimalarial pills

- Using a bed net and

- Keeping himself and his

- Protect himself against

- Only consuming food,

- Using treated water when

- Washing his hands.

- Washing his mess kit.

- Burying his waste.

- Maintain physical and mental

- Exercising.

- Preventing skin

- Preventing dental

- Preventing genital and

- Bathing when possible.

- Minimizing sleep loss.

- Improving resistance to

- Ensuring adequate

Wearing hearing protection while associated with source of noise (that is, aircraft, tactical vehicles, and all calibers of weapons).

Wearing eye protection when exposed to sources of traumatic injury such as lasers.

(2) *The field sanitation team.* The company field sanitation team consists of organic medical personnel; or at least two soldiers, one of whom is an NCO, when organic medical personnel are not available. The team is specially trained in water supply, food service sanitation, waste disposal, pest management, environmental injuries, and non-NBC chemical hazards (see FM 21-10-1). The field sanitation team serves as an aid to the unit commander in protecting the health of his company. Through regular inspections, the field sanitation team ensures sanitary standards are maintained and PVNTMED measures are practiced. Table 5-1 is helpful in identifying activities which are of PVNTMED significance.

5-40. Medical Training in the Field

a. Importance. Conducting medical training during a battalion FTX can be a challenge. When properly conducted, however, medical play can lend significant realism to training exercises. This benefits both the medical platoon and the battalion as a whole. The medical platoon learns to perform medical treatment and evacuation operations under simulated combat conditions. The battalion learns to complete its mission under situations in which it is suffering casualties. For information on planning for deployment to CTC, see Appendix G.

b. Lessons Learned. Previously, the key challenge in incorporating medical play into training exercises was sometimes convincing the battalion commander to do it. Fortunately, Combat Training Center experience has shown the need for realistic training to include medical play. Now, the challenge is in operating and reacting to realistic casualty scenarios. Again, this tests the initiative, creativity, and flexibility of medical platoon leaders. Observations and lessons learned at CTC are presented in Appendix G.

Table 5-1. Activities of Preventive Medicine Significance

ITEM OF INTEREST	DIVISION	LOCATION CORPS	PREVENTIVE MEDICINE SIGNIFICANCE
1. Maneuver companies	Highly dispersed and concealed.		Items of interest 1 through 3 contain
2. Maneuver battalions	Highly dispersed and concealed.		<ul style="list-style-type: none"> ● Combat soldiers subject to the medical threat.
3. Maneuver brigades	In the main battle area and in the reserve area.	In reserve.	<ul style="list-style-type: none"> ● Field kitchens that may be the source of disease. ● Medical companies that know how much preventable disease is occurring ● Unit headquarters that know the locations of subordinate units requiring preventive medicine support.
4. Main supply route (MSR)	Roads through brigade support area and division support area.	Roads through the corps support area.	Towns and villages can have diseases which will be spread along any MSR.
5. Airfields	Usually near division support area.	Staging areas on existing airfields and tactical airfields.	Airfields contain the aircraft used in aerial insect control missions. The supply points at airfields can be the focus of disease spread. The USAF weather stations can provide information useful for control of heat or cold injury and for aerial control of insect disease vectors.
6. Water points	Near brigade support areas.	Near base cluster.	Adequate quantities of potable water are required to sustain troops.
7. Ice plants	Villages.	Villages.	Village ice plants used for production of ice for use by US soldiers.
8. Ration breakdown and storage facilities/points	Brigade support area. Division support area.	Base clusters.	Bulk storage sites, refrigeration sites, and transportation units all handle potentially hazardous (perishable) foods which can cause disease.
9. Field dining facilities	Battalion trains.	Base clusters.	Kitchens and serving dining areas can all be sources of diarrheal disease.
10. Enemy-prisoner-of-war camps.	Division rear and back. Collection points forward.		MP company and stockade contain EPW who can be sources of communicable disease.

Table 5-1. Activities of Preventive Medicine Significance (continued)

ITEM OF INTEREST	DIVISION	LOCATION	CORPS	PREVENTIVE MEDICINE SIGNIFICANCE
11. Refugee camps.	Division rear off major supply route.		Corps rear off major supply route.	Forward tactical support company, rear area support company, and refugee camps can be the source of communicable disease.
12. Hospital dispensaries	Brigade support area. Division support area.		Base clusters.	Outpatient information on incidence of preventable disease; supplies for preventive medicine personnel.
13. Maintenance facilities	Brigade support area. Division support area.		Base clusters.	Vehicle refit/repair, equipment repair, and retrograde cargo site (all of these can have hazardous occupational exposures).
14. Laundries	Brigade support area. Division support area.		Base clusters.	Field laundry required to provide vermin-free clothing exchange.
<p>LEGEND:</p> <p>^a May serve as focal point for reservoirs of vector-borne diseases of military importance such as malaria, dengue, or leishmaniasis. If these areas are not targeted for preventive medicine support operations, interfacility transmission of vector-borne diseases will compromise the capabilities of medical personnel and other personnel in the surrounding area.</p>				

NOTE

The key to mission success is detailed preplanning. A HSSPLAN must be prepared for each support mission. Ensure that the HSSPLAN is in concert with the tactical plan. Use the plan as a starting point and improve on it while providing HSS.

CHAPTER 6

HEALTH SERVICE SUPPORT IN TACTICAL OPERATIONS

Section I. SUPPORT OF OFFENSIVE OPERATIONS

6-1. Offensive Operations

The offensive is the decisive form of war. It is the method by which wars are won. In combat, US forces will conduct offensive operations, whenever and wherever the opportunity presents. The battalion or battalion TF conducts offensive operations to achieve one or more of the following:

- Defeat enemy forces.
- Secure key or decisive terrain.
- Deprive the enemy of resources.
- Gain information.
- Deceive and divert the enemy.
- Hold the enemy in position.
- Disrupt an enemy attack.

6-2. Types of Offensive Operations

a. Major Types. There are five major types of offensive operations in which the battalion TF participates:

- Movement to contact.
- Hasty attack.
- Deliberate attack.
- Exploitation.
- Pursuit.

b. Task Force Participation. The TF normally participates in these operations as part of a larger force. Commanders at each level—

- Find or create a weak point.
- Suppress enemy fires.

- Isolate the enemy and maneuver against weak points.

- Exploit success.

6-3. Sequence of an Attack

Generally, the following sequence is followed in battalion TF attacks:

a. Reconnaissance. Reconnaissance begins as soon as possible after the TF receives its mission. Information on the avenues of approach, obstacles, and the enemy positions is critical to planning the attack. Reconnaissance continues throughout the attack.

b. Movement to a Line of Departure. When attacking from positions not in contact, units often stage in rear assembly areas. They road march to attack positions behind friendly units in contact with the enemy; conduct a passage of lines, then begin the attack.

c. Maneuver. The TF maneuvers to a position of advantage.

d. Deployment. The TF deploys to assault or to fix the enemy if bypassing.

e. Attack. The enemy position is engaged with fire; assaulted; or bypassed.

f. Consolidation and Reorganization or Continuation. The TF eliminates resistance and prepares for or conducts further operations.

6-4. Forms of Maneuver

a. Types of Attack. Attacks are of two basic types: hasty and deliberate. The two are distinguished primarily by the time available for planning and the extent of preparation. The basic forms of maneuver used in the attack are envelopment, penetration, frontal attack, and infiltration.

Frequently, attacks will use more than one form of maneuver; for example, a penetration that leads to an envelopment.

b. Envelopment. An envelopment is the preferred form of maneuver. In an envelopment, the attacker strikes the enemy's flank or rear. The envelopment causes the enemy to fight in a direction from which he is less prepared. Envelopment requires a weak flank, found primarily by aggressive reconnaissance.

c. Penetration. In the penetration, the battalion concentrates its force to rupture the defense on a narrow front, normally a platoon. The gap created is then widened to pass forces through to defeat the enemy and to seize objectives. A successful penetration depends on surprise and the attacker's ability to suppress enemy weapons; to concentrate forces at the point of attack; and to quickly pass sufficient forces through the gap to destroy the enemy's defense. A penetration is normally attempted when enemy flanks are strong, or when the enemy has a weak or unguarded gap in his defense. To penetrate a well-organized position requires a quick rupture and rapid destruction of the defense's continuity to deny him reaction time. Without rapid penetration, the enemy can reposition forces to block or counter the maneuver.

d. Frontal Attack. The frontal attack is the least preferred form of maneuver. In the frontal attack, the TF uses the most direct routes to strike the enemy. This attack is normally employed when the mission is to fix the enemy in position or deceive him. Although the frontal attack strikes the enemy's front, it does not require that the attacker do so in line or that all subordinate unit attacks be frontal. Frontal attacks, unless in overwhelming strength, are seldom decisive.

e. Infiltration. Infiltration is a form of maneuver where combat elements move by stealth to objectives to the rear of the enemy's position without fighting through prepared defenses. All or part of the TF may move by infiltration. Infiltrations are slow and are often conducted during reduced visibility. Success requires effective reconnaissance to discover and secure undefended routes. Such routes are normally found in rough terrain or in areas difficult to cover with observation and fire. The infiltrating elements avoid detection;

however, if detected they avoid decisive engagement.

6-5. Main and Supporting Attacks

In offensive operations, the commander designates main and supporting attacks.

a. Main Attack. The units conducting the main attack are assigned a mission which, when achieved, successfully accomplishes the TF's mission. The main attack secures a key terrain objective (position) or destroys an enemy force. Traditionally, terrain objectives have been assigned to the elements making the main attack; but attacks by fire to destroy an enemy force may also be the main attacker's mission.

b. Supporting Attack. The supporting attack allows the main attack to be successful. The supporting attack contributes to the success of the main attack by accomplishing one or more of the following:

- Occupying terrain to support-by-fire the maneuver of the main attack.
- Fixing the enemy in position.
- Deceiving the enemy as to the location of the main attack.
- Isolating the objective.

6-6. Synchronization of Offensive Operations

The commander and staff synchronize and integrate all combat, CS, and CSS assets that are available. The primary offensive employment of maneuver elements include—

a. Tanks. With their combination of mobility, firepower, and armor protection, tanks are the primary mounted assault element of the TF. Tanks are used to weight the main attack. Tanks may be assigned support-by-fire missions when their direct fires are needed to support assaults; or if obstacles initially prevent them from assaulting the enemy. Normally, tanks are employed in at least platoon strength. When a reserve is formed, tanks are normally allocated to it.

b. Infantry. Mounted infantry is used in the main attack when enemy antiarmor fires are weak or have been suppressed. Because of vulnerability to antiarmor fires, Bradley fighting vehicles (BFVs) are used to over-watch tanks or dismounted infantry when facing more than light antiarmor resistance. Dismounted infantry may lead by infiltration to clear obstacles or key enemy positions and disrupt the enemy's defense. Dismounted infantry can maneuver on untrafficable terrain to attack from an unexpected direction, permitting the resumption of mounted combat. Dismounted infantry may assault along with tanks against strong enemy resistance to protect the tanks from close-range antiarmor weapons. Infantry can also be used extensively in reconnaissance and counter-reconnaissance roles.

c. Antiarmor Company. In the offense, the antiarmor company maneuvers to provide over-watch and support-by-fire. Security and economy of force missions are also appropriate.

d. Scouts. During the offense, the scout platoon is employed in a security or reconnaissance role for the moving force. The primary mission for the scout platoon in the offense is reconnaissance.

e. Attack Helicopters. Attack helicopters may be employed by brigade to provide over-watch; to cover areas ground units cannot cover; or to rapidly mass to provide increased antiarmor capability. When this occurs, coordination is required to ensure synchronized application of combat power.

6-7. Health Service Support of Offensive Operations

a. General. The offensive operations of armored and mechanized forces are characterized by speed, heavy direct and indirect fires, and audacious, independent actions by subordinate elements. The potential for high casualty rates is greater for offensive operations than for any other type of operation. It follows that HSS for offensive operations will be a challenging endeavor. Through detailed planning and realistic training in peacetime, creative methods of supporting offensive operations may be developed. Some facts to consider in planning include—

- The M113A3, although an improvement over the A2, cannot match the top speeds of the M1 and the M2/3.
- The need for mobility may preclude the use of company aid posts and will limit BAS capabilities.
- Evacuation lines will lengthen.
- Combat medics may not be able to reach individual casualties in armored vehicles.
- Casualties will be incurred in uneven numbers among the attacking companies/company teams.

b. Health Service Support Guidelines. General guidelines for supporting offensive operations include—

- Pre-position medical evacuation vehicles as far forward as possible prior to the attack.
- Provide additional ambulance teams to main attack companies/teams.
- Request additional ambulances from the FSMC.
- Use patient collecting points.
- Use AXP's.
- Depend on combat lifesavers.
- Operate the BAS as treatment teams, leap frogging them forward as the attack progresses.
- Practice tailgate medicine.
- Concentrate on stabilization care and rapid evacuation.

6-8. Conduct of Offensive Operations

a. General. The remainder of this section discusses the conduct of specific offensive operations. It will provide a brief discussion of HSS

considerations for each operation. As the medical platoon leader, you must be familiar with these operations in order to plan HSS. In a broader sense, however, you should study military tactics in order to be a competent officer and leader.

b. Movement to Contact.

(1) *Battalion task force.* The battalion TF conducts a movement to contact to make or regain contact with the enemy and to develop the situation. Task forces conduct movement to contact independently or as part of a larger force. Normally, the battalion TF is given a movement to contact mission as the lead element of a brigade attack; or as a counterattack element of a brigade or division. Movement to contact terminates with the occupation of an assigned objective or when enemy resistance requires the battalion to deploy and conduct an attack to continue forward movement.

(2) *Organization of battalion task force.* During a movement to contact, the battalion TF is organized with a security force, advance guard, main body, and flank and rear guards. The security force, consisting primarily of the scout platoon, performs a screening and reconnaissance mission across the entire TF frontage. It operates 2 to 6 kilometers ahead of the advance guard. The advance guard usually consists of a company team the composition of which is dependent upon METT-T. It is the initial main effort and operates 1 to 2 kilometers ahead of the main body. The main body contains the bulk of the combat elements and is armed to achieve all-around security. The tactical CP follows the advance guard; the main CP moves behind the lead element of the main body. Flank and rear guards usually are platoon-sized elements under company control.

(3) *Characteristics of movement.* The movement to contact is characterized by a lack of information concerning the enemy's location and/or strength. Units conducting movement to contact are prepared for meeting engagements followed usually by a hasty or deliberate attack.

(4) *Health service support.* To support the movement to contact, medical personnel and evacuation vehicles are positioned within the battalion. One arrangement is to place one combat medic with the scouts; the company and platoon

medics with the other elements; two ambulance teams with the advance guard, one with each of the other companies, and the remainder with the treatment teams; split BAS elements into treatment teams with one following the tactical CP behind the advance guard and the other following the main CP in the main body. FSMC ambulances move with the main body. The uncertainty inherent in the movement to contact means the medical platoon must be prepared for any situation. Evacuation routes are planned throughout the axis of advance. Ambulance teams must know the location of the treatment teams at all times. The treatment teams must expect to perform tailgate medicine and facilitate rapid evacuation. The medical platoon must be prepared for a meeting engagement and whatever follows.

c. Hasty Attack.

(1) The hasty attack is conducted either as a result of a meeting engagement or when bypass has not been authorized and the enemy force is in a vulnerable (unprepared or unaware) position. Hasty attacks are initiated and controlled with fragmentation orders (FRAGOs).

(2) There are two categories of hasty attack.

- **Attack against a moving force.** When two opposing forces converge, the side that wins is normally the one that acts fastest and maneuvers to advantage positions on the opponent's flank. Task force contingency planning and quick reactions on contact facilitate the execution of a hasty attack. The advance guard attacks or defends, depending on the size and disposition of the enemy force. The TF commander maneuvers trailing or adjacent teams against the enemy's flank or rear, while attacking by fire and stopping enemy units attempting to do the same.

- **Attack against a stationary force.** A hasty attack against a stationary force (composed mainly of individual fighting positions and hasty protective obstacles) is begun after scouts or lead company teams reconnoiter the enemy's positions to find flanks or gaps that can be exploited. This must be done quickly to gain the initiative. The TF coordinates maneuver elements and supporting fires to avoid a piecemeal

commitment of combat power. Dismounted infantry assaults supported by direct and indirect fires may be necessary to defeat the enemy.

(3) **Support for the hasty attack** incorporates basic principles of HSS to offensive operations. In the hasty attack, little time will be available for planning and preparation. The tactical SOP is the primary guide to HSS operations in this case. Key considerations in support of hasty attacks are—

- Ensure rapid patient evacuation. (Preplan and use your evacuation SOP.)
- Maintain mobility by practicing tailgate medicine.
- Locate BAS/treatment teams near MSRs.

d. Deliberate Attack.

(1) **Characteristics.** Task force deliberate attacks differ from hasty attacks; they are characterized by precise planning based on detailed information, thorough preparation, and rehearsals. Deliberate attacks normally include large volumes of supporting fires, main and supporting attacks, and deceptive measures. The tank or mechanized infantry battalion will normally conduct a deliberate attack as the main or supporting effort of a brigade attack, or as the brigade reserve.

(2) **Health service support.** The deliberate attack is supported through a detailed, coordinated HSSPLAN. Task organize medical assets in support of elements in which high casualty rates are expected. Prepare a detailed overlay indicating current and future treatment team locations, AXPs, and primary and alternate evacuation routes. Inform the FSMC of the situation; request additional assets if necessary; and issue an OPORD to the medical platoon.

e. Exploitation.

(1) **Purpose.** The exploitation is conducted to take advantage of success in battle. Exploitation prevents the enemy from reconstituting an organized defense or conducting an

orderly withdrawal. It may follow any successful attack. The TF normally participates in the exploitation as part of a larger force. The keys to successful exploitation are speed in executing and maintaining direct pressure on the enemy.

(2) **Objective.** The TF conducting an exploitation moves rapidly to the enemy's rear area by using movement to contact techniques; they avoid or bypass enemy combat units, then destroy lightly defended and undefended enemy installations and activities. The TF is usually assigned an objective deep in the enemy rear based on the higher commander's intent. This objective may be one that will contribute significantly to the destruction of organized resistance or one for orientation and control.

(3) **Health service support.** In exploitation operations, speed becomes even more important. Medical elements must maintain their mobility; rapid treatment and evacuation are essential. Because an exploitation follows immediately upon a successful attack, medical supplies may become a problem. Ensure that necessary supplies are brought forward in FSMC ambulances. Use FSMC drivers to communicate urgent medical supply needs to the FSMC.

f. Pursuit.

(1) **Purpose.** The pursuit normally follows a successful exploitation. It differs from an exploitation in that a pursuit is oriented primarily on the enemy force rather than on terrain objectives. While a terrain objective may be designated, the enemy force is the primary objective. The purpose of the pursuit is to run the enemy down and destroy him.

(2) **Conduct.** The TF participates in the pursuit as part of a larger force. The pursuit is conducted using a direct-pressure force, an encircling force, and a follow-and-support force. The TF may comprise or be part of any of these forces.

- The direct-pressure force denies the enemy the opportunity to rest, regroup, or resupply by repeated hasty attacks; it forces them to defend without support or to stay on the move. The direct-pressure force envelops, cuts off, destroys, and harasses enemy elements.

- The encircling force moves with all possible speed to get in the enemy's rear, block his escape, and with the direct-pressure force, destroy him. The enveloping force advances along routes parallel to the enemy's line of retreat to establish positions ahead of the him.

- The follow-and-support force is organized to destroy bypassed enemy units; relieve

direct-pressure force elements; secure lines of communication; secure key terrain, or guard prisoners or key installations.

(3) *Health service support.* In pursuit operations, support is the same as for exploitation operations.

Section II. SUPPORT OF DEFENSIVE OPERATIONS

6-9. Defensive Operations

The purpose of defense is to defeat the enemy's attack and gain the initiative for offensive operations. Defensive operations achieve one or more of the following:

- Destroy the enemy.
- Weaken enemy forces as a prelude to the offense.
- Cause an enemy attack to fail.
- Gain time.
- Concentrate forces elsewhere.
- Control key or decisive terrain.
- Retain terrain.

and avoid easily targeted locations. The defender must use all available time to prepare fighting positions and obstacles; to rehearse counterattacks; and to plan supporting fires and CSS in detail.

b. Disruption. An attacker's strength comes from momentum, mass, and mutual support of maneuver and CS elements. The defender must slow or fix the attack; disrupt the attacker's mass, then break up the mutual support between the attacker's combat and support elements. This results in a piecemeal attack that can be defeated in detail. A general aim is to force the attacker to fight a nonlinear battle; to make the attacker fight in more than one direction. This makes it more difficult for him to coordinate and concentrate forces and fires; and to isolate and overwhelm the defender. It also makes securing his flanks, CS, CSS, and C² elements more difficult.

6-10. Characteristics of Defensive Operations

a. Preparation.

- The defender has significant advantages over the attacker. In most cases, he not only knows the ground better, but, having occupied it first, he has strengthened his positions. He is stationary and under cover in carefully selected positions, with prepared fires and obstacles.

- An enemy attack is preceded and accompanied by massed supporting fires. To survive, units must use defilade, reverse slope, and hide positions; use supporting and suppressive fires;

c. Concentration. To gain local superiority in one area, the defender is often forced to economize and accept risks elsewhere. Reconnaissance and security forces enable him to "see" the battlefield, and thereby reduce risk. The defender should be able to rapidly concentrate forces; mass combat power to defeat an attacking force, then disperse and prepare to concentrate again. The main effort is assigned to one subordinate unit. All other elements and assets support and sustain this effort. The commander may shift his focus by assigning a new unit as the main force, if other units encounter unexpected difficulties.

d. Flexibility. The commander designates reserves; deploys forces with logistic resources in depth to ensure continuous operations; and provides

options to the defender if forward positions are penetrated.

6-11. Framework of the Defense

The TF normally defends as part of a larger force. The defensive framework within which corps and divisions organize and fight consist of five elements.

- Deep operations forward of the forward line of own troops.
- Security force operations forward of and to the flanks of the defending force.
- Main battle area operations.
- Reserve operations in support of the main defensive effort.
- Rear operations to retain freedom of action in the rear area.

a. Deep Operations.

- Deep operations are actions against those enemy forces not yet in direct contact with the FLOT. Deep operations create opportunities for offensive action by reducing the enemy's closure rates; separating attacking echelons; disrupting his C, CS, and CSS; and slowing the arrival times of succeeding echelons. Deep operations are conducted using indirect fires, EW, USAF and Army aviation, deception, and maneuver forces.

- Task forces have no deep operations capabilities, although they may be part of a deep maneuver operation.

b. Close Operations.

- The forward security force normally established by corps is called a covering force. It begins the fight against the attacker's leading echelons in the covering force area (CFA). Covering force actions weaken the enemy; permit the corps commander to reposition forces; and deceive the enemy as to the size, location, and strength of the defense.

- A battalion TF may fight as a part of a covering force operation. When it disengages

from the enemy, it becomes part of the MBA forces or reserve. Main battle area units assume control of the CFA at the battle handover line; they assist covering force units to break contact and withdraw through the MBA.

c. Main Battle Area Operations.

- Based on their estimate of the situation and intent, brigade commanders assign sectors or battle positions (BPs) to TFs. Normally, assigned sectors coincide with a major avenue of approach, while BPs and attack helicopter firing positions are on the flanks of main approaches. The brigade commander designates and sustains the main effort by giving priority of CS assets to the force responsible for the most dangerous avenue of approach into the MBA. The commander can strengthen the effort on the most dangerous avenue by narrowing the sector of the unit astride it.

- Task force commanders structure their defenses by deploying units in depth within the MBA. A mounted reserve of up to one-half of the TF strength provides additional depth and gives the commander a maneuver capability against the enemy. A commander can create a reserve by taking risk on less likely enemy avenues of approach in the MBA.

- Penetration by enemy forces must be anticipated and provided for in the OPLAN. Separation of adjacent units is likely, especially if the enemy is conducting nuclear, biological, and chemical (NBC) operations. Main battle area forces continue to strike at the enemy's flank, and counterattack across penetrations.

d. Reserve Operations.

- The commitment of reserve forces at the decisive point and time is key to the success of a defense. The TF has been designated as a reserve force; it can expect to receive one or more of the following missions: counterattack; spoiling attack; block, fix, or contain; reinforce; or rear operations.

- When the TF designates a reserve, its most common use is in the counterattack role. The composition, location, and mission of a reserve is based on the TF commander's estimate of the situation and intent.

e. Rear Operations. The battalion TF does not have a rear operations fight within its assigned sector. However, a maneuver battalion assigned a rear mission by a higher headquarters may conduct offensive operations against enemy conventional or unconventional forces in the rear area.

6-12. Sequence of the Defense

A defense will often be conducted in the following sequence:

a. Occupation. During this phase, the scouts are usually the first to clear the proposed defensive position. They check for enemy OPs and NBC contamination. Leaders then reconnoiter and prepare their assigned areas. Security is established forward of the defense area to allow occupation of positions and preparation of obstacles without compromise. During occupation, movement is minimized to avoid enemy observation.

b. Passage of the Covering Force. The TF establishes contact with, and assists the disengagement and passage of the covering force or other security elements.

c. Defeat of Enemy Reconnaissance, Infiltration, and Preparatory Fires. Consistent with security requirements, TF elements remain in fortified positions to avoid casualties and shock associated with indirect fires. The enemy will attempt to discover the defensive scheme by reconnaissance and probing attacks of the advance guard. The enemy may also attempt to infiltrate infantry to disrupt the defense or to breach obstacles. Task force security forces must defeat these efforts using maneuver and fires.

d. Approach of the Enemy Main Attack. Task force security elements observe and report enemy approach movement. The TF commander repositions or reorients his forces to mass against the enemy's main effort. Enemy formations are engaged at maximum range by supporting fires and close air support to cause casualties; to slow and disorganize him; to cause him to button up; and to impair his communications. Obstacles are closed. Direct fire weapons are repositioned as required, or maneuvered to attack the enemy from the flank. The

TF commander may initially withhold fires to allow the enemy to close into an engagement area. Then at the decisive time, concentrate fires on the enemy.

e. Enemy Assault. As the enemy deploys, he becomes increasingly vulnerable to obstacles. The TF uses a combination of obstacles, blocking positions, and fires to break up the assaulting formation. Continued maneuver to enemy flank and rear is used to destroy him and to increase the number of directions to which he must react. Some security elements may stay in forward positions to monitor enemy second-echelon movement; and to direct supporting fires on these forces as well as on his artillery, AD, supply, and C² elements.

f. Counterattack. As the enemy assault is slowed or stopped, the TF commander will launch his counterattack (by fire or by maneuver) to complete the destruction of the enemy forces.

g. Reorganization and Consolidation. The TF must quickly reorganize to continue the defense. Attacks are made to destroy enemy remnants, casualties are evacuated, and units are shifted and reorganized to respond to losses. Ammunition and other critical items are cross-leveled and resupplied. Security and obstacles are reestablished and reports are submitted.

6-13. Types of Defense

The battalion TF will normally use three basic types of defense; defend a sector, defend a BP, and defend a strongpoint. Figure 6-1 summarizes the factors a commander considers in selecting a BP versus a sector.

a. Defense of a Sector.

- A defensive sector is an area designated by boundaries; it defines where a unit operates and the terrain for which it is responsible. Defense in sector is the most common defense mission for the TF.

- Defend in sector is the least restrictive mission. It allows the TF commander to plan and execute his defense using the best

technique to accomplish the mission. He may use sectors, BPs, strongpoints, or a combination of measures to accomplish his mission.

- To control his forces, the TF commander establishes coordinating points; phase lines; on-order BPs; and contact points.

b. Defense of a Battle Position.

- A BP is a general location and orientation of forces on the ground, from which units defend. The BP can be for units from battalion TF to platoon size. A unit assigned a BP is within the general area of the position. Security forces may operate well forward and to the flanks of BPs for early detection of the enemy and for all-around security. Units can maneuver in and outside of the BP as necessary to adjust fires or to seize opportunities for offensive action in compliance with the commander's intent.

- The commander may maneuver his elements freely within the assigned BP. When the

commander maneuvers his forces outside the BP, he notifies the next higher commander and coordinates with adjacent units. Task force security, CS, and CSS assets are frequently positioned outside the BP with approval from the headquarters assigning the BP.

c. Defense of a Strongpoint.

- The mission to create and defend a strongpoint implies retention of terrain with the purpose of stopping or redirecting enemy formations. Battalion strongpoints can be established in isolation when tied to restrictive terrain on their flanks. A bypassed strongpoint exposes the enemy's flanks to attacks from friendly forces.

- The TF pays a high cost in manpower, equipment, material, and time for the construction of a strongpoint. It takes several days of dedicated work to construct one. Strongpoints also sacrifice the inherent mobility advantage of heavy forces. Strongpoints may be on the FEBA, or in depth in the brigade MBA.

FACTOR	BATTLE POSITION	SECTOR
Avenues of approach	Well defined; enemy can be canalized	Multiple avenues prohibit concentration
Terrain	Dominates avenue of approach	Dominating terrain not available
Area of operations	Narrow	Wide
Mutual support between companies	Achievable	Cannot be achieved
Higher commander's ability to control	Good	Degraded

Figure 6-1. Defending from battle positions versus sectors.

6-14. Health Service Support in Battalion Defensive Operations

a. Flexibility in Support. To support a battalion defending in sector requires flexibility in adapting medical assets to the changing tactical situation. A sector defense combines offensive,

defensive, and retrograde actions within an overall mobile defense framework. This combination results in a nonlinear front which creates confusion among attacking forces and complicates HSS operations. The nonlinear front means that planned evacuation routes, usable in some sectors, may be blocked by enemy penetration in others. Some defending

elements may become temporarily encircled or bypassed by enemy forces. Rapidly moving enemy units may threaten or over-run the BAS.

b. General.

(1) *Difficulties encountered.* Health service support in the defense is more difficult than in the offense. Casualty rates may be lower, but due to the defensive rearward maneuver, patient collection and evacuation will be more complicated. Combat medics and ambulance teams will be exposed to more direct enemy fires. They will have less time to locate, treat, and evacuate the wounded. Defensive operations will generally produce higher casualty rates among medical personnel, thereby reducing treatment and evacuation capabilities.

(2) *Health service support plan.* The medical platoon should use the defensive preparation time to resupply combat medics and to replace battle losses. The platoon leader and medical operations officer should develop a detailed HSSPLAN. They should contact the FSMC and thoroughly coordinate the HSS relationship. Either the medical platoon leader or the medical operations officer must participate in the TF's battle planning. When planning and coordinating HSS for defensive operations, consider the following actions:

- Select covered and concealed BAS and company aid post sites.
- Ensure adequate medical supplies are available. If necessary, request additional supplies.
- Plan for evacuation within the defensive area.
- Plan and coordinate in detail evacuation by the FSMC from BAS to the DCS.
- Plan to continue HSS should the unit become encircled.
- Consider the potential of having to hold patients for an indefinite period of time, without adequate resources.
- Discuss with the FSMC commander the possibility of positioning a FSMC treatment team within the BP/strongpoint.

(3) *Patient load.* The heaviest patient load can be expected during the initial phase of the enemy attack. Many casualties will be evacuated using nonmedical vehicles during this phase (FM 8-10-6). The BAS, operating as a whole or as separate treatment teams, should be established further rearward than in offensive operations. Evacuation lines will shorten as the forward companies maneuver rearward. Communication difficulties may arise due to enemy jamming. Enemy use of NBC weapons is possible.

(4) *Increased risk.* Health service support to a battalion defending from a BP or a strongpoint is considerably different from that for a sector defense. Battle positions and strongpoints are restrictive measures which limit maneuver. Reduced dispersion will create shorter interval evacuation lines and a more centralized, controlled medical operation. The reduced dispersion also creates increased risk of high casualty rates. Evacuation out of a BP or strongpoint may be difficult or temporarily impossible.

c. Covering Force Support.

(1) *Problem encountered.* Support to a covering force can be extremely complicated. The covering force will most likely face a much larger enemy force. It is expected to trade minimum geographic space for maximum time. To be effective, the covering force must remain highly mobile and avoid decisive engagement. The medical platoon of a covering force unit faces all of the difficulties inherent in defensive operations. Its mission is further complicated by the rapid movement and overpowering number of attacking units.

(2) *Employment.* The medical platoon of a covering force unit will most likely choose to operate its BAS in the split team configuration. It should concentrate on providing expeditious stabilizing care and rapidly evacuating patients. Combat medics and evacuation sections should be employed as for any other defensive operation. When participating in a covering force operation, mobility of the medical platoon is critical.

(3) *Preparation.* Some preparation time may be available prior to enemy contact. During this time, the medical platoon leader meets with the

supporting FSMC commander rider or covering force medical staff officer. A detailed HSSPLAN is prepared. The medical platoon leader must know who is providing evacuation support (a covering force medical company or one from the MBA). Priorities for use of nonmedical vehicles are established with the commander and S3. The medical platoon leader must clearly establish with his unit commander situations under which patients may be abandoned. This information is disseminated so that medical elements can continue to operate without communications and while taking casualties among themselves.

d. Battle Handover.

(1) *Transition.* As the covering force moves to the rear, the TF commander prepares for the battle handover. The handover is the transition from the CFA battle to the MBA battle in which the MBA forces begin to engage the enemy.

(2) *Coordination requirements.* The battle handover can be a hazardous operation and requires extensive coordination. Covering force area forces will have conducted an intense fight and may be considerably attrited. They may require assistance in reaching and passing through MBA forces. In the worst case, handover presents the potential for confusion, disorganization, and

resultant high casualty rates within both CFA and MBA elements. The medical platoon must be prepared for this.

(3) *Health service support coordination.* The medical operations officer should contact the CFA battalion/TF medical operations officer to coordinate HSS responsibilities for the battle handover and rearward passage, if possible. If the CFA element has suffered heavy casualties, they may require augmentation of personnel/equipment; if casualties have been light, they may be able to provide the MBA medical platoon with Class VIII supplies or evacuation assistance, as necessary. The medical operations officer should then contact the FSMC and pass on information concerning enemy forces; casualty experience; evacuation routes; requisite site selection; and possibly logistical assistance.

(4) *Operation.* The medical operations officer must stay on top of the tactical situation in order to maneuver treatment teams and evacuation assets. Patient collecting points and AXP's will contribute to HSS efforts. Treatment by CLS and combat medics will be essential. Company medics and evacuation NCOs must be capable of performing independently; this will ensure continuity of HSS under disrupted communications or loss of key medical leaders.

Section III. SUPPORT OF RESERVE OPERATIONS

6-15. Reserve Operations

When designated as a reserve for a higher headquarters, the battalion TF may be assigned one or more of the following missions:

- Counterattack.
- Spoiling attack.
- Block, fix, or contain enemy force.
- Reinforce.
- Rear operations.

Given more than one mission, the TF commander develops, plans, coordinates, and prepares for execution of his contingencies based on established priorities.

6-16. Counterattack

a. *Attack Assignment.* Counterattack planning and execution is assigned by brigade to committed and reserve TFs. Normally, more than one counterattack option is planned for and rehearsed. Counterattacks may be conducted to block an impending penetration of the FEBA; to stop a force that has penetrated; to attack through forward defenses to seize terrain; or to attack enemy forces from the flank and rear.

b. Timing the Attack. A counterattack, at any level, is usually the decisive point in an engagement. The commander's timing in committing his reserve to the counterattack is critical. To ensure success, the counterattack must be well planned and precisely executed. The battalion medical operations officer must be in touch with the tactical scenario and prepared to execute the HSSPLAN.

c. Health Service Support. In preparing and executing the HSSPLAN, consider the following

- Forward movement may be very swift. Medical assets must keep up.
- Ambulance teams should move with supported companies.
- If attack covers a broad frontage, consider splitting BAS into two treatment teams.
- The initial engagement will be violent and decisive.
- The commander may be forced to continue the mission under high casualty rates.
- A successful counterattack will likely result in the capture of EPWs; some EPWs will be in need of medical treatment.
- Consideration for support of offensive operations apply.

NOTE

The Geneva Convention requires that wounded enemy prisoners receive medical care equal to that given to friendly casualties. We will, of course, meet this requirement. However, it is important to remember to search the prisoner and forward any documents found to the S2. For additional information on EPW care, see Appendix H.

6-17. Spoiling Attack

This is a preemptive, limited objective attack aimed at preventing disrupting or delaying the enemy's ability to launch an attack. The objective of the spoiling attack is the enemy force, not terrain. The reserve is often used to conduct spoiling attacks so that forward units can concentrate on defensive preparations within the MBA. Spoiling attacks are normally directed against an enemy force that is preparing to conduct an attack; that has temporarily halted to rearm and refuel; or is making the transition from mounted to dismounted operations. Enemy artillery is also a prime target.

NOTE

Health service support considerations for offensive operations apply.

6-18. Block, Fix, or Contain

The reserve may be ordered to establish a hasty BP to block, fix, or contain enemy forces within a portion of the battlefield. This action may be necessary to blunt a penetration while other forces maneuver against the flanks or rear of the enemy force. An enemy force may be held in one area of the battlefield while he is defeated in another.

NOTE

Health service support considerations for offensive operations apply.

6-19. Reinforce

Reserve forces may be committed to reinforce units that have sustained heavy losses; also to build up stronger defenses in critical areas of the battlefield. Considerations must be given to how they will be integrated into the defensive scheme, ^C arrangements, and where they will be positioned. The techniques used to reinforce are similar to those used during a relief in place.

6-20. Rear Operations

a. Execution. The reserve battalion may operate as a division combined arms tactical combat force with a rear operations mission. The TF must not allow itself to become so dispersed that it cannot mass for other reserve missions. Nevertheless, the TF normally uses dispersed company positions; this reduces the TF signature on the battlefield and helps spread its companies to accomplish rear operations. The TF completes intelligence preparation of the rear area for probable enemy avenues of approach and for likely enemy landing zones (LZs) and drop zones (DZs). It positions forces at the locations to interdict the rear area threat. Based on the IPB, location of CS and CSS elements within the brigade rear area, and their own dispositions, the TF assigns areas of responsibility to its companies or teams. Task forces are responsible for their own security within assigned areas. The TF also coordinates with CS and CSS base clusters for their defense, to include—

- Critical CS and CSS assets to be protected.
- Intelligence preparation of the battlefield, to include local enemy approaches and possible LZs/DZs.
- Review of base and base cluster defensive preparations to include perimeter

defensive sketches, OPs, patrols, obstacles, AD weapons sites, and reaction forces.

- Coordination of fire support.
- Coordination for aviation operations including reconnaissance, fire support, and transport.
- Coordination with MP and other combat-capable units and base cluster reaction forces.
- Events or contingencies that will trigger commitment of the TF to destroy a rear area threat.

b. Health Service Support. The dispersion common to a battalion performing a rear operations mission complicates the HSS situation. Evacuation lines are lengthy. Use AXPs and FSMC or MSMC ambulances, if practical. Company aid posts are vital and must operate somewhat autonomously—company medics must know their business. Due to the dispersion, the BAS may choose to operate as separate treatment teams. Level II support may come from the MSMC in the DSA—if this is a new support relationship it should be well coordinated.

Section IV. SUPPORT OF RETROGRADE OPERATIONS

6-21. Retrograde Operations

Retrograde operations are organized movements away from the enemy. A retrograde may be forced by enemy action or executed voluntarily. The underlying reason for conducting a retrograde operation is to improve a tactical situation or prevent a worse one from occurring. A retrograde operation may be used to economize forces, maintain freedom of maneuver, or avoid decisive combat. A battalion TF conducts a retrograde as part of a larger force to—

- Avoid combat under unfavorable conditions.
- Gain time.
- Reposition or preserve forces.
- Use a force elsewhere.
- Harass, exhaust, resist, and delay the enemy.

- Draw the enemy into an unfavorable position.
- Shorten lines of communication and supply.
- Clear zones for friendly use of chemical or nuclear weapons.
- Conform to the movement of other friendly forces.

6-22. Types

There are three types of retrograde operations: delay, withdrawal, and retirement. They can be characterized as follows:

- Delay—trade space for time and avoid decisive engagement to preserve the force.
- Withdrawal-break contact. (Free a unit for a new mission.)
- Retirement-move a force not in contact to the rear.

6-23. Planning Considerations

All retrogrades are difficult and inherently risky. To succeed, they must be well organized and well executed. A retrograde operation requires the following elements:

a. Leadership and Morale. Maintenance of the offensive spirit is essential among subordinate leaders and troops in a retrograde operation. Movement to the rear may be seen as a defeat or a threat of isolation; therefore, soldiers must have confidence in their leaders and know the purpose of the operation and their role in it.

b. Reconnaissance, Surveillance, and Security. Timely and accurate intelligence is especially vital during retrograde operations. Reconnaissance and surveillance must locate the enemy; then security elements must deny him information and counter his efforts to pursue; outflank; isolate; or bypass all or a portion of the TF. The commander must establish a security force that is strong enough to—

- Secure enemy avenues of approach.
- Deceive the enemy and defeat his intelligence efforts.
- Overwatch retrograding units.
- Provide rear guard, flank security, and choke point security.

c. Mobility. To conduct a successful retrograde, the TF seeks to increase its mobility and significantly slow or halt the enemy.

- The TF improves its mobility by—
 - Reconnoitering routes and BPs.
 - Positioning AD and security forces at critical points.
 - Improving roads, controlling traffic flow, and restricting refugee movement to routes not used by the TF.
 - Rehearsing movements.
 - Evacuating casualties, recoverable supplies, and excess materiel before the operation.
 - Displacing nonessential CSS activities early in the operation.
 - Covering movements by fire.
- The TF degrades the mobility of the enemy by—
 - Occupying and controlling choke points and terrain that dominate high speed avenues of approach.
 - Destroying roads, bridges, and rafting on the avenues not required for friendly forces.
 - Improving existing obstacles and covering them with fire.
 - Employing indirect fire and smoke to degrade the enemy's vision and to slow his

rate of advance. To ensure continuous coverage, TF mortars normally move in split sections.

- Conducting spoiling attacks to keep the enemy off balance and force his deployment.

d. Deception. The objective of deception is to hide the fact that a retrograde is taking place; this is essential for success. Deception is achieved by maintaining normal patterns of activity in radio traffic; artillery fires; patrolling and vehicle movement. Additional considerations include using dummy minefield or decoy positions, and conducting feints and demonstrations under limited visibility conditions. Retrograde plans are never discussed on unsecure radio nets.

e. Conservation of Combat Power. The commander must conserve his combat power by—

- Covertly disengaging and withdrawing less mobile units and nonessential elements before withdrawing the main body.

- Using mobile forces to cover the withdrawal of less mobile forces.

- Using minimum essential forces to provide security for withdrawal of the main body.

6-24. Delay

a. Purpose. A delay is an operation in which a force trades space for time while avoiding decisive engagement. The delay incorporates all of the dynamics of defense, but emphasizes preservation of the force and maintenance of a mobility advantage. The TF may attack, defend, or conduct other actions (such as ambushes and raids) during the delay to destroy the enemy or to slow the enemy. The battalion TF may be given a delay mission as part of the covering force; as an economy-of-force operation to allow offensive operations in another sector; or to control a penetration to set up a counterattack by another force.

b. Control of Actions. A delay may be conducted from successive positions or from alternate positions. Successive positions are used when the delay is conducted over a wide front; alternate positions are preferred for a narrow sector.

The delay is normally well planned and uses graphic control measures to display the commander's intent. Incorporate these control measures in the HSS overlay.

c. Health Service Support. Detailed HSS planning is essential to the medical platoon's ability to support a delay operation. The nature of a delay, with its inherent mix of operations (offensive, defensive, and retrograde), creates a complicated battlefield situation. Combat medics, evacuation NCOs, and other key medical personnel must have a good understanding of the commander's intent and the HSSPLAN. This will occur if planning is effective and includes the following considerations implicit in delay operations:

- Expect evacuation difficulty. Patient evacuation in delay operations is complicated due to the changing forward and rearward movement; to possible communication disruptions; and to congested evacuation routes.

- Ambulance crews may be at increased hazard due to the rearward movement of the force.

- Locate BAS further toward the rear.

- Consider operating separate treatment teams to support the successive or alternate positions.

- Plan for possible necessity to abandon patients.

- Plan for frequent BAS relocations.

- Plan for future operations; what happens when the retrograde ends?

6-25. Withdrawal

A withdrawal is an operation in which all or part of the battalion frees itself for a new mission. A withdrawal is conducted to break contact with the enemy when the TF commander finds it necessary to reposition all or part of his force; or when required to attain separation for employment of special purpose weapons. It may be executed at any time, during any type of operation. There are two types of

withdrawals—withdrawal not under enemy pressure and withdrawal under enemy pressure. Both types begin while the battalion is under the threat of enemy interference. Preferably, withdrawal is made while the battalion is not under enemy pressure. Withdrawals are either assisted or unassisted. An assisted withdrawal uses a security force provided by the next higher headquarters in breaking contact with the enemy and to provide overmatching fires. In an unassisted withdrawal, the TF provides its own security force.

6-26. Retirement

a. Purpose. A retirement is a retrograde operation in which a force that is not in contact with the enemy moves to the rear in an organized

manner. A retirement is usually made at night. If enemy contact is possible, on-order missions are given to the march units.

b. Leadership Responsibilities. A retirement may have an adverse impact on the morale of friendly troops. Leadership must be positive; they must keep troops informed of the retirement purpose and future intentions of the command.

c. Health Service Support. Support of a withdrawal or retirement should be conducted much as for a movement to contact. However, in a withdrawal or retirement, most of the medical vehicles are in the rear of the main body. Since these operations are normally conducted as part of a larger force, necessary coordination with the FSMC should be relatively easy.

Section V. SUPPORT OF OTHER TACTICAL OPERATIONS

6-27. Passage of Lines

a. Purpose. A passage of lines is an operation in which one unit is passed through the positions of another. When a unit moves toward the enemy through a stationary unit, it is a forward passage. Rearward passages are movements away from the enemy through friendly units. The covering force withdrawing through the MBA, or an exploiting force moving through the initial attacking force, are examples.

b. Conduct. A passage of lines is necessary when one unit cannot bypass another. A passage of lines may be conducted to—

- Continue an attack or counter-attack.
- Envelop an enemy force.
- Pursue a fleeing enemy.
- Withdraw covering forces or main battle forces.

c. Vulnerability of Units. The TF is vulnerable during a passage of lines. As units are

concentrated, the fires of the stationary unit may be masked and the TF is not dispersed to react to enemy action. Detailed reconnaissance and coordination are key to ensure a quick and smooth passage.

d. Health Service Support. The passage of lines may offer the medical platoon leader the opportunity to interface with his counterpart in the unit being passed. This is an excellent opportunity to share information concerning enemy forces; casualty experience; evacuation routes; requisite site selections; and possibly logistical assistance. The passage of lines can be a hazardous operation, particularly when conducted while in contact with the enemy. Health service support must be planned and coordinated between participating units.

6-28. Relief Operations

a. Responsibilities. A relief is an operation in which a unit is replaced in combat by another unit. Responsibilities for the mission and assigned sector or zone of action are assumed by the incoming unit. Reliefs may be conducted during offensive or defensive operations and during any weather or light conditions. They are normally executed during

limited visibility to reduce the possibility of detection.

b. Purpose. The purpose for relief is to maintain the combat effectiveness of committed elements. A relief may be conducted to—

- Reconstitute a unit that has sustained heavy losses.
- Introduce a new unit into combat.
- Rest units that have conducted prolonged operations.
- Decontaminate or provide medical treatment to a unit.
- Conform to a larger tactical plan or make mission changes.

6-29. Breakout from Encirclement

a. Encircled Force. A breakout is an offensive operation conducted by an encircled force. A force is considered encircled when all ground routes of evacuation and reinforcement are cut off by the enemy.

b. Conduct. A breakout is conducted to allow the encircled force to regain freedom of movement; or to regain contact with friendly units. Encirclement does not imply that the battalion TF is surrounded by enemy forces in strength. Threat doctrine stresses momentum and bypassing of forces that cannot be quickly reduced. An enemy force may be able to influence the TF's subsequent operations while occupying only scattered positions; it may not be aware of the TF location, strength, or composition. The TF can take advantage of this by attacking to break out before the enemy is able to take advantage of the situation.

c. Health Service Support. During the breakout, patients will most likely have to be transported by combat units using nonmedical organic assets. Health service support (treatment) will have to be delayed until the breakout is completed.

6-30. Linkup

a. Purpose. A linkup is the meeting of two or more friendly ground forces that have been separated by the enemy. The battalion TF may participate as part of a larger force, or it may conduct a linkup with its own resources. Linkup is conducted to relieve or join a friendly force, or to encircle an enemy force.

b. Coordination of Maneuver Schemes. All elements in a linkup carefully coordinate their operations to minimize the risk of fratricide. This coordination is continuous and increases as the units approach the linkup points. Control measures used are as follows:

- Zones of attack or axes of advance. If one or more of the forces are moving, their direction and objective are controlled by the higher headquarters.

- Phase lines. Movement is controlled by a higher headquarters through the use of phase lines.

- Restrictive fire lines. Restrictive fire lines (RFLs) are used to prevent friendly forces from engaging one another with indirect fires. One technique is to make the phase lines on-order RFLs. As the unit crosses a phase line, the next phase line becomes the RFL.

- Checkpoints. Checkpoints are used to control movement and designate overwatch positions.

- Linkup and alternate linkup points. The linkup point is a designated location where two forces meet and coordinate operations. The point must be easily identifiable on the ground, and recognition signals must be planned. Alternate linkup points are established in the event that enemy action precludes linkup at the primary point.

c. Health Service Support Implications. Tailgate medicine will be employed during linkup movement. Upon linkup, all medical assets will be consolidated into a medical platoon operation.

6-31. Guard Operations

a. Mission. A guard operation is a security operation in which a unit protects a larger unit by—

- Maintaining surveillance.
- Providing early warning.
- Destroying enemy reconnaissance elements.
- Preventing enemy ground observation of main body.
- Preventing enemy use of direct fire against the main body.

b. Functions. The guard force provides the larger force warning, reaction time, and maneuver

space. The guard force delays, destroys, or stops the enemy within its capability. The commander conducting the guard operation must know the intent of the higher force commander and the degree of security required.

c. Performance. Guard operations can be to the front, rear, or flanks of the main body. Battalion TFs have the mobility, organization, and equipment to perform a guard operation as a part of a brigade or division offensive operation. They may be assisted by air cavalry or attack helicopter units under their OPCON.

d. Health Service Support. Health service support for offensive operations (paragraph 6-7) equally apply to guard operations.

Section VI. SPECIAL OPERATIONS

6-32. General

Health service support is limited to the same degree as combat effectiveness when operating in areas of extreme weather and/or terrain hazards. Medical units require special purpose equipment (primarily shelter and transportation) in quantities commensurate with their support mission to overcome these restrictions. Operations in freezing or extremely hot temperatures require continuing protection of medical items that deteriorate rapidly. Environmental restrictions may reduce the capability of the division's evacuation assets; therefore, litter bearers and ground/air ambulance elements must be reinforced with other medical and/or nonmedical resources. Medical treatment elements require special shelter protection which neutralizes extremes in weather adapts easily to difficult terrain; and can be erected and dismantled quickly. Unusual types and larger numbers of patients often result from prolonged exposure to extreme natural hazards; therefore, prevention is the most effective method in dealing with extreme conditions. Abnormally high numbers of patients require augmentation of division treatment and/or evacuation resources.

6-33. Mountain Operations

a. The tactical problems of the division medical companies in mountain operations are similar to those encountered in other terrain. Lack of good road networks will add to the difficulties. One DCS should be established in support of each committed brigade. These should be as close as possible to the BAS supported, yet must be situated so as to permit easy evacuation by the units in support. Use of ambulances forward of the DCS may be impossible. Personnel normally employed in this link of evacuation may be used as litter bearers; or they may supervise litter bearers furnished from other sources. Problems will arise, but by maximum use of personnel and equipment, the division medical company can give support within its area of responsibility.

b. Troops operating in mountainous terrain are subject to unusual illnesses; these include mountain sickness, high altitude pulmonary edema, and cerebral edema. All three are caused by rapid ascent to altitudes of 2,400 meters (about 7,875 feet) and above. They can be prevented in most soldiers

by acclimation, progressive ascent, and slow assumption of physical activities. For more detailed information on mountain operations see FM 90-6.

c. Mountain operations require medical personnel to carry additional equipment. Items such as ropes, pitons, piton hammers, and snap links are all necessary for the evacuation of patients and establishment of a BAS. Unnecessary items of equipment including those for which substitutes or improvisations can be made are left behind. Heavy tentage, bulky chests, extra splint sets, excess litters, and non-essential medical supplies should be stored. If stored, these supplies should be readily available for airdrop or other means of transport. Medical items that are subject to freezing must not be exposed to the low temperature experienced in mountainous areas.

d. For forward medical elements to maintain a satisfactory level of medical supplies, all personnel, vehicles, and aircraft going forward should carry small amounts of medical supplies and equipment; examples are blood substitutes, dressings, and blankets. Smaller supplies and equipment may be rolled in blankets and lashed to backboards or carried in partially folded litters.

e. Since the transportation of heavy tentage may be impracticable, shelter for patients must be improvised to prevent undue environmental exposure. In the summer or in warm climates, improvisation may not be necessary, but there is a close relationship between extreme cold and shock; thus medical personnel should always consider the need to provide shelter for patients. Shelter may be found in caves, under overhanging cliffs, behind clumps of thick bushes, and in ruins. They may be built using a few saplings, evergreen boughs, shelter halves, or similar items. The time a patient is to be held will influence the type of shelter used. When patients are to be kept overnight, a better weatherproofed shelter must be constructed.

f. The evacuation of patients in mountain warfare presents varied problems. In addition to the task of carrying a patient to the nearest medical element, there is the difficulty of moving over rough terrain.

(1) The proportion of litter cases to ambulatory cases is increased in mountainous

terrain; even a slightly wounded individual may find it extremely difficult to move across the terrain. Because of the added exertion and increased pain, it may be necessary to transport a patient by litter who would normally return to the BAS by himself.

(2) In cold weather and in high mountains, speed of evacuation is vital; there is a marked increase in the possibility of shock among patients in extreme cold.

(3) Special consideration must be given to the conservation of manpower. Litter hauls must be kept as short as the tactical situation will permit. A litter team is not capable of carrying a patient for the same distance over mountainous terrain as over flat territory. To decrease the distance of litter hauls, medical elements should locate as close as possible to the troops supported.

(4) It is important to be able to predict the number of patients that can be evacuated with available personnel. It has been demonstrated that when the average terrain grade exceeds 20° to 25° the four-man litter team is no longer efficient; it should be replaced by a six-man team. The average mountain litter team should be capable of climbing 120 to 150 vertical meters of average mountain terrain and return with a patient in approximately one hour.

(5) Another problem is evacuation at night. The wounded should be located and evacuated during the day. Many casualties would not survive the rigors of the night on a mountain in cold weather. Night evacuation over rough terrain is impractical and results are rarely equal to the effort. When possible the night evacuation route should be marked with tracing tape and rope handlines; they are installed during daytime. However, if routes are exposed to enemy observation and fire by day, patients must be removed from the area by night; but only as far as necessary. At the first point affording shelter from enemy observation and fire, a holding station should be established; shelter, warmth, food, and supportive care should be provided. Patients should be brought from forward areas to this point; they are held until daylight, then evacuated to the rear.

(6) Before initiating evacuation, conduct a reconnaissance of the terrain and the road

network in the area. To this, add information on climatic conditions, facilities and personnel available, and the tactical mission. Only after all of these factors are assembled and evaluated can a sound medical evacuation plan be formulated. The following factors peculiar to mountain operations should be considered before making the final selection of evacuation routes:

- Snow and ice are firmest during the early morning hours.
- Glacial or snow fed streams are shallowest during the early morning.
- Mountain streams afford poor routes of evacuation because of rough, slippery rocks and the force of moving water.
- Talus slopes (those slopes with an accumulation of rock debris strewn around) should be avoided; they are difficult to traverse. Loose and slippery rocks on such slopes will often cause litter bearers to fall or drop the patient; compounding his existing injury and possibly causing injury to members of the litter bearer team.
- Choose routes that are just below the crest of a ridge. These trails are usually easiest to follow and the ground affords the best footing.

(7) The difficulties of medical evacuation encountered in mountain operations emphasize the advantages of air evacuation. The time between injury and treatment is a determining factor in the patient's recovery. Evacuation by air, which is the most rapid, most comfortable, and the safest means is the optimum method. However, total reliance on air ambulances is inadvisable; rapidly changing weather conditions in mountainous areas adversely affect aeromedical evacuation. All available means of collection and evacuation should be used.

g. When operating in mountainous terrain, the maneuver battalion is often decentralized to an extent that a centrally located BAS is not practical. In these circumstances, it may be necessary to split the medical platoon into two small sections capable of minimal HSS. Close-terrain conditions severely limit the platoon's capabilities; personnel and equipment augmentation may be required.

h. In mountainous terrain, there is usually adequate concealment and defilade to allow the medical platoon to establish the BAS close to the FLOT. If one station is operated, it should be located as close as possible to the fighting troops, generally in the center of the battalion's area of operations. If the platoon is required to operate more than one treatment site, each treatment team is given a specified area of responsibility; it is located centrally as far forward as possible in support of the troops for which the station is responsible. The term *centrally* located does not necessarily mean the geographical center of an area. Many factors must be considered in determining a central location for a given area. These include expected patient loads; lines of drift; roads or paths for evacuation to and from the station; and terrain features having a direct influence on litter carry. The following advantages are obtained when consideration is given to the location of BAS:

- Relatively short or easy litter hauls.
- Medical facilities closer to the units they support.
- Closer contact with company commanders affords greater ease in following changes in the tactical plan.
- Adequate shelter.

Patients are sorted, given necessary emergency medical care, RTD, or provided shelter and warmth until transportation becomes available.

i. When the BAS is in a split mode, it is desirable that the medical platoon headquarters section be augmented with additional six-man litter teams. The augmentation litter teams may be recruited from all available sources (including the use of indigenous personnel); they must be familiar with military mountaineering techniques. The augmentation should be completed before the actual need.

j. As in normal situations, combat medics will be furnished to the rifle companies by the medical platoon. Insofar as possible, combat medics are always allocated to the same company (and platoon); this encourages close relationship between them and the men of the company. Emphasis should

be placed on training the combat medics in hazards of cold and wind; relationship of these factors to the problem of shock; conservation of body heat and improvised methods of providing warmth (to include the construction of small windbreaks and shelters); and techniques of military mountaineering and mountain evacuation procedures.

k. Supported companies should establish patient collecting points.

(1) In mountainous terrain, it will often be necessary to consider the establishment of patient collecting points. These patient collecting points operated by combat medics are designated intermediate points along the route of evacuation where patients may be gathered. Whenever patients are to be transferred from one type of transportation to another, a patient collecting point/AXP is needed.

(2) Defilade positions are abundant in mountainous areas. Patient collecting points should be established as far forward as possible. An AXP may be established behind each of the BASS, or a centrally located point may be operated; whichever will ensure the most efficient HSS and provide the greatest relief to litter bearer personnel.

(3) Patient collecting points are movable and should be placed, whenever possible, away from difficult terrain. Patient collecting points along routes of march should not be established routinely, unless—

- It is certain that these points will be in territory under secure control of friendly forces.
- The number or severity of wounded justifies such a point.

l. Litter relay points may also have to be established during mountain operations.

(1) If sufficient litter bearers are available, a chain of litter relay points, from the BAS to a point where evacuation can be taken over by ambulances, should be established.

(2) Each relay point should have one NCO and four litter bearers. However, when short of

personnel, one NCO could be used to supervise more than one relay point. Each point is responsible for the evacuation of all patients received. When returning to their relay point, litter bearers bring empty litters and other medical supplies which are required by forward medical personnel. This will permit maximum use of available litter bearers; litter bearers operating in a chain of relay points can evacuate far more wounded than teams attempting to evacuate the wounded from the frontline to the BASS; or from the BASS to the ambulance pickup point. Personnel can rest on the return to their post; they also become familiar with the short section of mountain trail over which they travel. This makes it possible for them to operate over the trail at night; also gives the wounded a much smoother ride.

6-34. Jungle Operations

a. Difficult terrain, wide dispersion of combat units, inadequate roads, and insecure lines of communication all have a direct influence on HSS in jungle operations. The manner in which medical units support tactical organizations depends on how they are employed. Wide variations may be expected, but the general principles of HSS will apply.

b. The evacuation of wounded in jungle warfare presents difficult problems. Ambulances may not be practical on trails, unimproved muddy roads, and in swamps. There is a higher proportion of litter cases; even a slightly wounded individual may find it impossible to walk through dense undergrowth. As a result, the patient normally classified as ambulatory may become a litter case. Evacuation is usually along supply routes which are adequately protected against enemy action.

c. The organization of the medical company is such that it will support divisional elements on an area basis. Ambulances may be replaced by other more maneuverable vehicles. Air evacuation may be used to relieve surface transportation. Waterways may afford a good route of evacuation. Army air ambulances equipped with rescue hoists are a fast and efficient means of evacuation in the jungle.

d. There are other problems encountered in jungle operations; personal hygiene and sanitation is a serious and continuous one. as is the incidence of

diseases peculiar to jungle areas. The incidence of fungus diseases of the skin is especially serious. In addition to maintaining high standards of personal hygiene and sanitation, strict preventive medicine measures must be observed and enforced at all times (refer to paragraph 4-19b(4)). For more detailed information on jungle operations see FM 90-5. For management of skin disease, see FM 8-40.

- Vast distances and isolation.
- The lack of maps can adversely affect mobility, firepower, and communications.

In spite of these conditions, operations are accomplished; they require employment of aggressive leadership; a high state of training and full logistical support.

6-35. Cold Weather Operations

a. The environment in cold weather operations is a primary factor. Individuals must understand the effects of the cold environment; they must have the training, stamina, and willpower to take protective actions. In this climate, the human element is all-important; The effectiveness of equipment is greatly reduced; therefore, specialized training and experience are essential. The climate does not allow a margin of error for the individual or the organization. The mobility of units is restricted; their movement must be carefully planned and executed; a movement can be as difficult to overcome as the enemy. Momentum is difficult to achieve and can be quickly lost.

b. With modifications, current Army divisions are suited for operations in cold weather (see FM 31-71). Changes in personnel and equipment authorizations are the result of emphasis on mobility; maintenance; communications; and CSS. Equipment is eliminated or added based on its suitability to the terrain and environment.

c. The conduct of military operations is limited by considerations that are foreign to more temperate regions:

- Long hours of daylight and dust of summer.
- Long nights with bitter cold and storms of winter.
- Mud and morass of the transition periods of spring and autumn.
- Disrupting effects of natural phenomena.
- Scarcity of roads and railroads.

d. Because of the hostility of cold weather, units operating in northern latitudes should establish a relatively short patient holding period. Adverse environmental conditions make it difficult for medical units to provide definitive care over an extended period. The evacuation policy is changed as the tactical situation dictates. The general nature of the terrain makes surface evacuation of patients difficult in winter and virtually impossible in summer. The lack of good evacuation routes and the need to move supplies over the same route greatly restrict patient evacuation. The most practical means of patient evacuation is air evacuation. Aircraft resupplying the area can be used to carry patients on the return trip. Total reliance on air evacuation must be avoided; aircraft operations will be restricted by cold weather conditions.

e. To enhance HSS in extremely cold weather, the following operational principles apply:

- (1) Prompt acquisition and evacuation of patients to heated treatment stations.
- (2) Augmentation of unit collecting elements by division level medical elements.
- (3) Use of enclosed and heated vehicles for medical evacuation.
- (4) Provision of heated shelters at frequent intervals along the evacuation route.
- (5) Readily available air transportation for patient evacuation.
- (6) Special vehicles for surface evacuation of patients.
- (7) Heated storage for medical supplies.

f. In the deep snows, storms, and bitter cold of winter, prompt evacuation and treatment of patients is even more essential. It is extremely difficult to find and evacuate patients; early medical care can be rendered only if medical personnel are immediately available. Procedures should be established for medical care on patrols, at strong-points, and in heated aid stations near front lines. If medical personnel are not readily available, other personnel must promptly evacuate patients. Medical treatment elements must be well forward in the combat area to prevent unnecessary losses due to evacuation delays.

6-36. Desert Operations

a. Planning for HSS is especially important in the desert; the greater distances used in maneuver and deployment complicate medical treatment, evacuation, and supply procedures. Roads and trails are scarce and usually connect villages and oases. Wheeled vehicles can travel in any direction over much of the desert; they need not be confined to roads and trails because much of the desert area is flat and hard surfaced. Limited water supplies, coupled with the increased demands created by very high temperatures, low humidity, and dust, cause additional concerns for HSS planners. Use FM 90-3 when preparing HSS plans for desert operations.

b. The greater distances between units limit the availability of combat medics. Medical units should be augmented when possible; also troops should be given additional first aid training before desert operations.

c. The large area over which a battle is fought presents special problems in the timely acquisition, treatment, and evacuation of patients. Any number of patients in a fighting unit may restrict the maneuverability of that unit and jeopardize its mission. Medical units are furnished a greater number of evacuation vehicles for operating in deserts. Medical treatment elements are located farther to the rear in desert operations. Medical evacuation by fixed-wing aircraft and helicopters is valuable because of their speed and the reduced turnaround time.

d. Many diseases of military significance may be found in the desert. The diseases are found in its human inhabitants, animals, arthropods, and local water and food supplies. The cold of the desert night, even in summer, may require warm clothing. Cold weather injuries may occur during the desert winter. It is the desert sunshine, wind, and heat, however, that have the greatest effect upon military operations. The dryness of the desert heat distinguishes it from the heat of the tropics; this adds to the problem of coping with it. Medical elements must be provided additional water supplies to treat heat injuries (heat cramps, heat exhaustion, and heat stroke). All water, except from quartersmaster water points, is considered contaminated and unfit for drinking it may also be unfit for bathing or for washing clothing.

e. Intestinal diseases tend to increase among personnel living in the desert. This may be prevented by good food service sanitation, including supervision of cleaning eating and cooking utensils; supervision of food handlers; disposal of garbage and human wastes; and protection of food and utensils. Solid wastes should be burned when the situation permits. Soakage pits are used to dispose of liquid wastes; they are filled with soil when leaving an area. Deep pit latrines should be used if the soil is suitable. Arthropods and rodents must be controlled to prevent the diseases they carry. Preventive medicine measures include protective clothing; clothing impregnants; arthropod repellents; residual and space sprays; immunizations; and suppressive drugs. Incidence of disease will be reduced by individuals applying preventive medicine measures; practicing good field sanitation and personal hygiene avoiding food and water from native villages; and constant command/medical supervision.

6-37. River Crossing Operations

a. The river barrier itself exerts decisive influence on the use of HSS units. Attack across a river line creates a medical problem comparable to that of the amphibious assault. Medical elements cross as soon as combat operations permit. Early crossing of treatment elements reduces turnaround time for all crossing equipment which must load patients on the far shore. Maximum use is made of air evacuation assets to prevent excessive patient

buildup in far shore treatment facilities. Near shore treatment facilities are placed as far forward as assault operations and protective considerations permit; this reduces evacuation distances from off-loading points. For more detailed information on river operations, see FM 90-13.

b. In defensive operations, HSS resources deployed on the far shore are restricted to the minimum needed to provide support. Evacuation from far shore treatment facilities is accomplished using both surface and air evacuation; this reduces the accumulation of patients forward of the river barrier. Near shore treatment facilities are located farther to the rear to preclude their having to displace in a cross-river withdrawal. Defilade locations are avoided for medical elements because they are prime target areas for enemy artillery and air attack.

c. Health service support in the attack of river lines, while conforming in general to the HSS doctrine of offensive operations, present special problems during ferrying and bridging operations. Health service support must concern itself with the support of the combat troops during the advance to the river line (preliminary phase); during the river crossing and capture of the initial objective (phase I); during operations to seize the intermediate objective (phase II); and during the attack to gain the bridgehead (phase III).

(1) *Health service support preliminary phase.* There are relatively few patients resulting from this phase when secrecy in movement to the river is maintained. Patient collecting points may not be established along the main approaches to the crossing sites.

(2) *Health service support, phase I.* At the end of the preliminary phase, BAS and DCSs are established to provide normal support in the area of each crossing. Litter bearers may be employed near each crossing site. Ambulances are moved as near to the river as possible. Medical platoons furnish close HSS; combat medics accompany their companies in the crossing. Ambulance squads organic to the medical platoons cross in succeeding waves; and the treatment squad establishes the BAS on the far bank as soon as the situation permits. Patients are placed on returning craft for evacuation to the near bank. When helicopters are employed as a means of

air landing assault troops, the returning aircraft may be used to evacuate patients to medical treatment elements on the near bank. Air ambulance elements provide air evacuation of patients from the far bank during phase I if the tactical situation allows air assault operations.

(3) *Health service support, phase II.* During this phase, the FSMC provides evacuation on both banks of the river until a DCS has been established on the far bank. When phase II is nearing completion, the DCS is moved forward to a position close to the near bank or across to the far bank as conditions dictate. A relatively high priority is granted to division HSS elements for movement across any established bridges. In the absence of bridges, movement of HSS elements is accomplished by surface craft or air.

(4) *Health service support, phase III.* During this final phase, HSS units are moved across the river as rapidly as possible; they resume normal operations on the far bank. Division clearing stations may be called upon to care for a larger number of patients, pending the establishment of bridges and the resumption of normal evacuation by higher command.

6-38. Rear Operations and Area Damage Control

a. Rear operations consist of those actions, including area damage control, taken by all units (combat, CS, CSS, and host nation) singly or in combination to secure the force; to neutralize or defeat enemy operations in the rear area; and to ensure freedom of action in deep and close-in operations. It is a system designed to ensure continuous support.

b. Area damage control operations are those measures taken before, during, or after a hostile action or a natural or man - made disaster to minimize its effects.

c. Health service support is provided by division medical companies, medical platoons, and medical sections. These units establish and operate a BAS/DCS on or near the edge of the damage area.

d. See FM 90-14 and FM 3-100 for additional information on area damage control operations.

6-39. Military Operations on Urbanized Terrain

a. *General.* Throughout history, battles have been fought on urbanized terrain. Some recent examples are the battles for Manila, Stalingrad, Hue, Beirut, and Panama City. Military operations on urbanized terrain (MOUT) are planned and conducted on a terrain where man-made structures impact on the tactical options available to the commander. This terrain is characterized by a three-dimensional battlefield, having considerable rubble; ready-made fortified fighting positions; and an isolating effect on all combat, CS, and CSS units. In this environment, the requirement for a detailed HSSPLAN cannot be overstated. Medical and tactical planners must plan, train, prepare, and equip for patient evacuation from under, at, and above ground level. An additional concern in urbanized terrain is the increased potential for disease transmission due to disruption of utilities (water, sewage, waste disposal), the large numbers of refugees and displaced persons, and breakdowns in sanitation and personal hygiene.

b. *Equipment Requirements.* Materiel requirements for HSS of MOUT includes unique equipment, especially for the extraction and the evacuation of patients.

- Axes, crowbars, and other tools used to break through barriers.

- Special harnesses, portable block and tackle equipment, grappling hooks, collapsible stretchers and SKED stretchers, lightweight collapsible ladders, heavy gloves, and blankets with shielding for use in lowering patients from buildings or moving them from one building to another at some distance above the ground using ropes and pulleys.

- Equipment for the extraction of patients from tracked vehicles, safe and quick retrieval from craters, basements, sewers, and subways. Patients may have to be extracted from beneath rubble and debris.

- The anticipated increase in wounds and injuries requires increased supplies of intravenous (IV) resuscitation fluids. Individual soldiers may carry these fluids to hasten their availability and shorten the time between wounding and initiation of vascular volume replacement.

- Air ambulances equipped with a rescue hoist may be able to evacuate patients from the roofs of buildings or may be able to insert needed medical personnel and supplies. The use of SKED stretchers expedites patient hoisting.

- Effective communications face many obstacles during MOUT. Line of sight radios are not effective. Individual soldiers will not have access to radio equipment. Alternate forms of communications, such as markers, panels, or field expedients (fatigue jacket or T-shirt), which can be displayed by wounded or injured soldiers indicating where they are, may be employed.

c. *Nonmaterial Requirements.*

(1) Patient collecting points should be established at relatively secure areas accessible to both ground and air ambulances. Life- or limb-threatening injured or wounded soldiers should be evacuated by air ambulance, when available. Patient collecting points should be designated in advance of the operation and should—

- Offer cover from enemy fires.
- Be located as far forward as the tactical situation permits.
- Be identified by an unmistakable feature (natural or man-made).
- Allow rapid turnaround of ambulances.

(2) Route markings to the MTF and display of the Geneva Red Cross at the facility must be approved by the tactical commander. Camouflaging the Red Cross can forfeit the protections, for both medical personnel and their patients, afforded under the Geneva Convention. Refer to Appendix H for additional information. The site selected must be accessible, but separated from lucrative enemy targets, as well as civilian hazards such as gas stations or chemical factories.

(3) Medical evacuation in the MOUT environment is a labor-intensive effort. Much of the evacuation effort must be accomplished by litter teams; this is due to rubble, debris, barricades, and destroyed roadways. When this occurs, an ambulance shuttle system or litter shuttle should be established. Medical personnel must be able to use and teach manual carries, as well as improvise as the situation dictates. In moving patients, you should—

- Use covered evacuation routes such as storm water sewers and subways. Sanitary sewers should not be used; there is a danger of methane gas buildup in these systems.
- Use easily identifiable points for navigation and patient collecting points.
- Rest frequently by using a litter shuttle system.

(4) Self-aid, buddy aid, and the CLS skills are essential in this environment. Due to the nature of MOUT, injured and wounded soldiers may not be reached by the combat medic for extensive periods of time. The longer the period between injury or wounding and medical treatment, the poorer the prognosis. Therefore, units operating in this environment must ensure that all soldiers are proficient in self-aid and buddy aid, and that CLS are trained. In paragraph b above, it is recommended that each soldier carry IV resuscitation fluids with him so that the CLS can initiate replacement fluid therapy before the combat medic reaches the casualty. The soldier's chance for survival increases when he begins receiving IV resuscitation fluids early.

d. Ground Evacuation. When using ground evacuation in support of MOUT, the HSS planner must remember that built-up areas have many obstructions to vehicular movement. Factors requiring consideration include—

- Vehicular operations within the urban terrain are complicated and canalized by rubble and other battle damage.
- Bypassed pockets of resistance and ambushes pose a constant threat along evacuation routes.

- Land navigation using tactical maps proves to be difficult. Commercial city maps can aid in establishing evacuation routes, when available.

- Ambulance teams must dismount, search for, and rescue casualties.

- Movement of patients becomes a personnel intensive effort. There are insufficient medical personnel to search for, collect, and treat the wounded. Litter bearers and search teams will be required from supported units, as the tactical situation permits.

- Refugees may hamper movement into and around urban areas.

- Civilian personnel, detainees, and enemy prisoners of war are provided medical treatment in accordance with the command policy and the Geneva Convention.

e. Aeromedical Evacuation. When using aeromedical evacuation assets in support of MOUT, the medical planner must consider enemy AD capabilities and terrain features (both natural and man-made) within and adjacent to the built-up areas.

(1) Factors which may affect the use of air ambulances are—

- Movement is highly restricted and is canalized over secured areas, down wide roads, and open areas.

- Telephone and electrical wire and communications antennas hinder aircraft movement.

- Secure landing zones must be available.

- Landing zones may include buildings with helipads on their roofs or sturdy buildings, such as parking garages.

- Snipers with AD capabilities may occupy upper stories of taller buildings.

(2) Helicopters remain the preferred method of evacuation.

f. Training. In addition to the self-aid, buddy aid, and CLS training, HSS personnel must be familiar with the tactics, techniques, and procedures used by the combat soldier in MOUT.

(1) For HSS personnel to survive and serve in this environment, they must know how to—

- Cross open areas safely.
- Avoid barricades and mines.
- Enter and depart buildings

safely.

- Recognize situations where booby traps or ambushes are likely and are advantageous to the enemy.

(2) Many of the techniques used in a mountainous terrain for the extraction and

evacuation of patients can be applied to medical evacuation in a MOUT. By using the SKED stretcher, the patient can be secured inside the litter for ease in vertical extractions and evacuations.

(3) Health service support personnel must practice and become proficient in using a grappling hook, scaling walls, and rappelling. Rappelling techniques can be used to gain entry into upper levels of buildings as well as accompanying the patient during vertical extraction and evacuation.

(4) Detailed information on the conduct of combat operations in the urban environment is contained in FM 90-10-1. Additional information on HSS to MOUT is contained in FMs 8-42 and 8-10-6. Health service support planners and providers must be proficient in the skills required for this environment.

Section VII. HEALTH SERVICE SUPPORT IN A NUCLEAR, BIOLOGICAL, CHEMICAL, OR DIRECTED ENERGY ENVIRONMENT

6-40. General

a. On future battlefields, the enemy may employ NBC weapons and directed energy (DE) devices. Chemical, biological, and DE protective measures and procedures to mitigate the effects of nuclear weapons must be included in the medical platoon training programs and daily operations. This section provides guidance for HSS during nuclear warfare, enemy biological or chemical attack, and enemy employment of DE devices. The material presented in this section emphasizes contingency planning for immediate problems confronting HSS units following enemy actions. The large numbers of patients, the loss of MTFs and personnel from NBC attacks, and DE device employment will reduce our capability to provide HSS.

b. Nuclear, biological, chemical, and DE actions create high casualty rates, materiel losses, obstacles to maneuver, and contamination. Mission-oriented protection posture Level 3 and 4 results in body heat buildup, reduces mobility, and degrades

visual, touch, and hearing senses. Laser protective eyewear may degrade vision, especially at night. Individual, and ultimately, unit operational effectiveness and productivity are degraded.

c. Contamination is a major problem in providing HSS in an NBC environment. To increase survivability as well as supportability, the medical platoon must take necessary action to avoid NBC contamination. Maximum use must be made of—

- Alarm and detection equipment.
- Unit dispersion.
- Overhead cover, shielding materials, and collective protective shelters.
- Chemical agent resistant coatings.

Generally, a biological aerosol attack will not significantly impact materiel, terrain, or personnel in the short term. Detailed information on characteristics and soldier dimensions of the nuclear

battlefield; NBC operations; extended operations in contaminated areas: NBC decontamination; NBC contamination avoidance; and NBC protection are contained in Field Manuals 8-285, 8-250, 8-50, 3-100, 3-5, 3-4, and 3-3.

d. On the integrated battlefield HSS is focused on keeping the soldier in the battle. Effective and efficient triage and emergency treatment in the operational area saves lives, assures judicious evacuation, and maximizes the return to duty rate.

6-41. Medical Planning Factors

a. To provide HSS, definitive planning and coordination is required at all levels of command.

This includes provisions for treatment, evacuation, and hospitalization. Field Manuals 8-285, 8-55, 8-9, and TM 8-215 contain additional information in planning for HSS operations. Higher headquarters must distribute timely plans and directives to subordinate units. Provisions for emergency medical care of civilians, consistent with the military situation, must be included.

b. The medical platoon leader should make a quick appraisal to determine the expected patient load. Consider the use of triage and EMT decision matrices for managing patients in a contaminated environment. A sample decision matrix is shown in Figure 6-2. Training medical personnel in the use of these matrices should enhance their effectiveness in providing HSS.

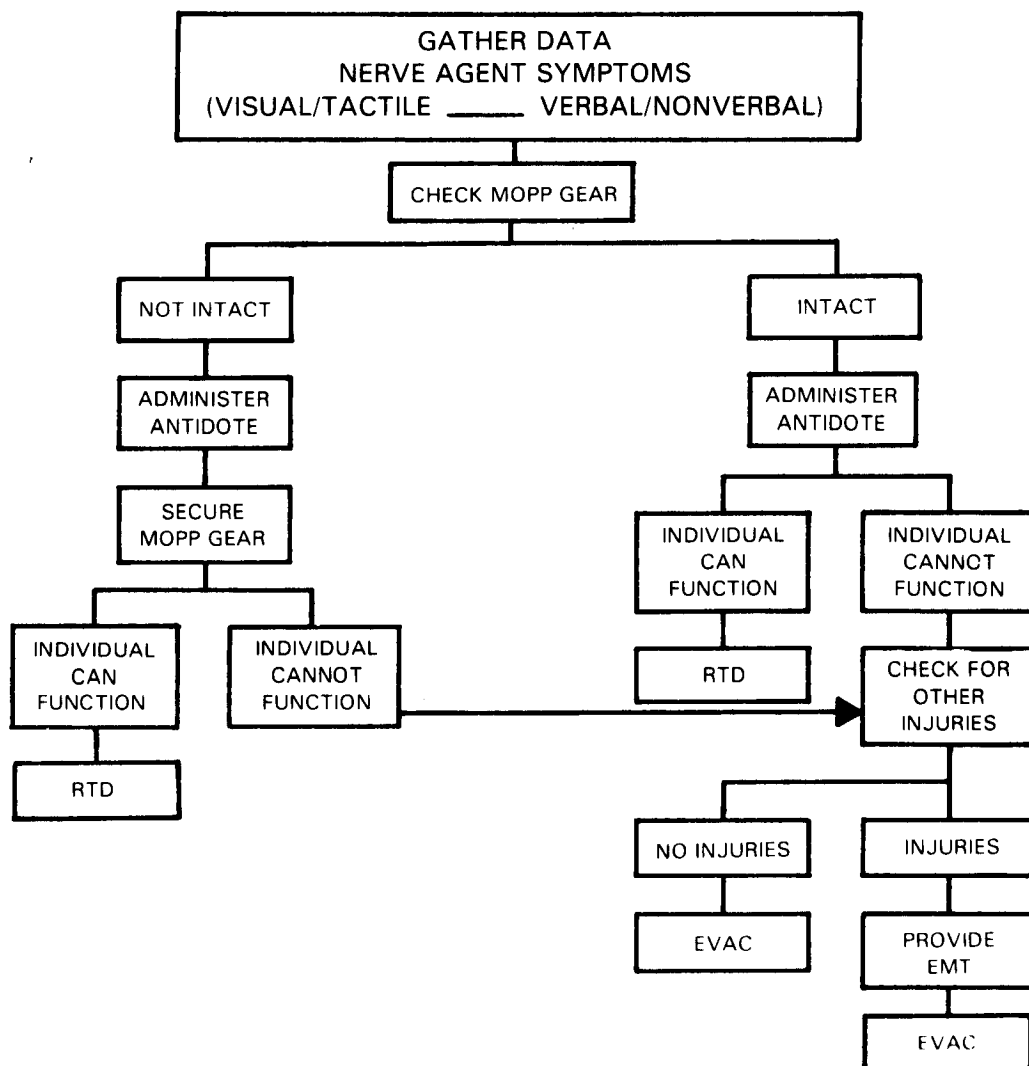

Figure 6-2. Sample triage and EMT decision matrix.

6-42. Logistical Considerations

a. The medical platoon is organized and equipped to provide support in a conventional environment. However, it must be trained and prepared to operate in all battlefield situations. Employment in an NBC environment will necessitate the issue of chemical patient treatment sets, and chemical patient decontamination sets.

b. The DMSO maintains a 48-hour contingency stock level of Class VIII supplies. These medical supplies and equipment must be protected from contamination by chemical agent. Class VIII stocks are dispersed to prevent or reduce damage or contamination caused by NBC weapons. Health service support plans include the protection (NBC hardening) of contingency stocks and the rapid resupply of affected units. Contaminated items are decontaminated prior to issue to using units.

c. The division PVNTMED section is responsible for testing the quality of water for the division. Water from local sources (lakes, ponds, or public water systems) is subject to being contaminated; therefore, it is essential to test the local source for contaminants before use. Frequent retesting by water production personnel is recommended. Once a water source is contaminated, it is marked with appropriate NBC contamination markers. The water is not used until a determination is made that it is safe for use, or water treatment equipment capable of removing the contaminants is employed. When water becomes contaminated, it is disposed of in a manner that prevents secondary contamination; the area is marked. All water dispensing equipment is monitored frequently for possible contamination. Water supply on the NBC battlefield is provided on an area basis by elements of the supply and transportation battalion. Water supply is normally provided to maneuver elements through unit distribution.

6-43. Personnel Considerations

During NBC actions, HSS requirements will increase and medical reinforcement may be necessary. Following an enemy NBC attack, or employment of DE devices, medical personnel will be fully active in providing emergency medical care;

they will provide more definitive treatment as time and resources permit. Nonmedical personnel should provide search and rescue of the injured or wounded; provide immediate first aid; and perform decontamination procedures. Nonmedical personnel will be needed to man the patient decontamination station at the BAS (FM 8-285 and TC 8-12). The requirement for nonmedical personnel should be included in the battalion tactical SOP.

6-44. Disposition of Treatment Elements

Site selection factors dictate that the BAS not be located at or near likely target areas. Selecting a covered and concealed site is extremely important in a potential NBC environment.

a. A minimum of eight medical personnel are required to operate a collective protective shelter (CPS) system and provide medical care. One EMT NCO performs triage and EMT on patients before decontamination. One aidman monitors the patient during decontamination procedures. Two aidmen monitor and provide care to patients when they leave the decontamination site. These individuals care for patients awaiting admission to the CPS; they also provide care for RTD or other patients requiring evacuation without receiving treatment in the CPS. One medic operates from the CPS airlock. He removes patient's protective mask and monitors patient's prior to their entering the interior of the CPS. He also assists with treatment in the CPS. The physician and PA operate inside the CPS with the assistance of the airlock aidman and one additional aidman.

b. Operation of CPS systems at the BAS in a chemical environment requires more than four medical personnel. This is why the squad does not split into teams. A viable method of obtaining additional HSS in the area of operations would be to request additional medical teams from the FSMC.

c. The BAS is equipped with two medical equipment sets for chemical agent patient treatment and one medical equipment set for chemical agent patient decontamination. Each set has enough consumable supplies for the decontamination and treatment of sixty chemical agent patients. These sets are also used at clearing stations, corps and COMMZ hospitals, and dispensaries to decontaminate and treat chemical

agent patients. The number of sets vary, depending on the treatment site.

6-45. Civilian Casualties

Civilian casualties may become a problem in populated or built-up areas; the BAS may be required to provide assistance when civilian medical resources cannot handle the workload. Aid to civilians, however, will not be undertaken at the expense of health services for US personnel.

6-46. Nuclear Environment

a. The medical platoon must be capable of supporting the maneuver unit's operations in a nuclear environment. The three damaging effects of a nuclear weapon are blast, thermal radiation (heat and light), and nuclear radiation (principally gamma rays and neutron particles). Well-constructed foxholes with overhead cover and expedient shelters (for example, reinforced concrete structures, basements, railroad tunnels, or trenches) provide good protection from nuclear attacks. Armored vehicles also provide protection against both the blast and radiation effects of nuclear weapons. Casualties generated in a nuclear attack will likely suffer concurrent injuries (for example, a combination of blast, heat, and radiation injuries) which will complicate HSS. Nuclear radiation casualties fall into three categories:

- Irradiated casualty. The irradiated casualty is one who has been exposed to ionizing radiation, but is not contaminated. They are not radioactive, and pose no radiation threat to medical care providers. Casualties who have suffered exposure to initial nuclear radiation will fit into this category.

- Externally contaminated casualty. The externally contaminated casualty has radioactive dust and debris on his clothing, skin, or hair. He presents a "housekeeping" problem to the BAS, similar to the vermin-infested patient arriving at a peacetime MTF. The externally contaminated casualty should be decontaminated at the earliest time consistent with required HSS. Lifesaving care is always rendered, when necessary, before decontamination is accomplished. Radioactive

contamination can be monitored with a radiation detection instrument such as the AN/PDR-27 or AN/VDR-2. Removal of the outer clothing will result in greater than ninety-percent decontamination; soap and water can be used to further reduce the contamination levels. A contaminated patient, or even several contaminated patients are unlikely to present a radiation hazard to attending medical personnel.

- Internally contaminated casualty. The internally contaminated casualty is one that has ingested or inhaled radioactive materials, or has had radioactive material injected into the body through an open wound. The radioactive material continues to irradiate the casualty internally until radioactive decay and biological elimination removes the radioactive isotope. Attending medical personnel are shielded, to some degree, by the patient's body. Inhalation, ingestion, or injection of quantities of radioactive material sufficient to present a threat to medical care providers is highly unlikely.

b. Medical units operating in a residual radiation environment will face three problems—

- Immersion of the treatment facility in fallout, necessitating decontamination efforts.

- Casualty production due to gamma radiation.

- Hindrances to evacuation caused by the contaminated environment.

6-47. Medical Triage

Medical triage, as discussed in earlier sections, is the classification of patients, according to the type and seriousness of injury. This achieves the most orderly, timely, and efficient use of medical resources. However, the triage process for nuclear patients is different than for conventional injuries. The four categories for triage of nuclear patients are:

- Immediate treatment group (TI). Those requiring immediate lifesaving surgery. Procedures should not be time-consuming and concern only

those with a high chance of survival, such as respiratory obstruction and accessible hemorrhage.

- Delayed treatment group (T2). Those needing surgery but whose conditions permit delay without unduly endangering safety. Life -sustaining treatment such as intravenous fluids, antibiotics, splinting, catheterization, and relief of pain may be required in this group. Examples are fractured limbs, spinal injuries, and uncomplicated burns.

- Minimal treatment group (T3). Those with relatively minor injuries, such as minor fractures or lacerations, who can be helped by untrained

personnel or look after themselves. Buddy care is particularly important in this situation.

- Expectant treatment group (T4). Those with serious or multiple injuries requiring intensive treatment, or with a poor chance of survival. These patients receive appropriate supportive treatment compatible with resources, which will include large doses of analgesics as applicable. Examples are severe head and spinal injuries, widespread burns, or high doses of radiation; this is a temporary category.

The effect of radiation on the triage of patients is shown in Table 6-1.

Table 6-1. Radiation Dosage and Degradation of Treatment Priority

Serial	Starting Priority	Final Priority		
		Less than 150 cGy	150-550 cGy	Over 550 cGy
1	Radiation Only	Duty or T3	T3**	T4
2	T1	T1	T1 or T4*	T4
3	T2	T2	T2 or T4*	T4
4	T3	T3	T3**	T4
5	T4	T4	T4	T4

* In the case of full or partial thickness burns covering more than 18 percent of the body surface or trauma which would either result in significant infection or be categorized as severe but not immediately life threatening, such as a fractured femur. This is a clinical decision and not necessarily subjectively reproducible.

** Includes the probable requirements for antibiotics and transfusion at a later time. So this classification does not suggest that the patient is not in need of treatment, but rather that he does not need immediate specialized care.

6-48. Biological Environment

a. A biological attack (using bomblets, rockets, or spray/vapor dispersal, release of arthropod vectors, and terrorist/insurgent contamination of food and water, frequently without immediate effects on exposed personnel) may be difficult to recognize. The medical platoon must monitor biological warfare indicators such as:

- Increases in disease incidence or fatality rates.

- Sudden presentation of an exotic disease.

- Other sequential epidemiological events.

b. Passive defense measures such as immunizations, good personal hygiene, physical conditioning, using arthropod repellents, wearing protective mask, and good sanitation practices will mitigate the effects of most biological intrusion.

NOTE

Normally, biological agents delivered as a vapor will be nonpersistent.

c. Decontamination of most biologically contaminated patients can be accomplished by bathing with soap and water.

d. Treatment of biological agent patients will require observation and evaluation of the individual to determine necessary medications.

6-49. Chemical Environment

a. Handling chemically contaminated patients may provide the greatest challenge to medical units on the integrated battlefield. All casualties generated in a liquid chemical environment are presumed to be contaminated. Due to the vapor hazard associated with contaminated patients, medical personnel operating BAS and DCS without a collective protective shelter (CPS) system may be required to remain at MOPP level 4 for long periods of time. When CPS systems are not

available, clean areas must be located for treating patients.

b. A patient processing station for chemically contaminated patients must be established by the medical platoon to handle the influx of patients (Figure 6-3). Generally, the station is divided by a "hotline" into two major working areas; a contaminated working area situated downwind of a clean working area. Personnel on both sides of the "hotline" assume a MOPP level commensurate with the threat agent employed (normally MOPP 4). The patient processing station should be established in a contamination-free area of the battlefield. When CPS systems are not available, the clean treatment area should be located upwind 30 to 50 meters of the contaminated work area. When personnel in the clean working area are away from the hotline, they may reduce their MOPP level, especially the physician and PA. Chemical monitoring equipment must be used on the clean side of the hotline to detect vapor hazards due to slight shifts in wind currents; if vapors invade the clean work area, medical personnel may have to remask to prevent low level chemical agent exposure and minimize clinical effects (such as miosis).

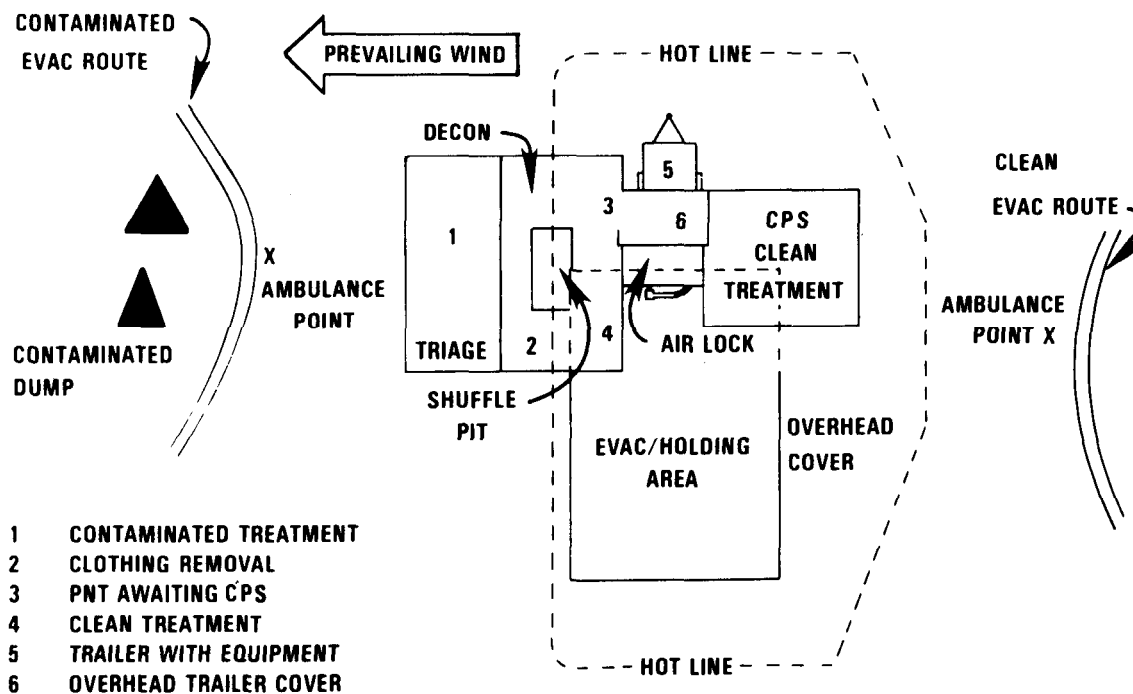

Figure 6-3. BAS patient processing station and protective shelter.

c. Initial triage, emergency medical treatment, and decontamination are accomplished on the “dirty” side of the hotline. Life-sustaining care is rendered, as required, without regard to chemical contamination. Secondary triage, ATM, and patient disposition are accomplished on the clean side of the hotline. When treatment must be provided in a contaminated environment, outside of CPS, the level of care may be reduced to first aid procedures because treaters are in MOPP 3 or 4.

d. Medical platoons will require augmentation with nonmedical personnel to meet patient decontamination requirements created by a chemical attack. This augmentation must come from the supported units. See Appendix E for operating a patient decontamination station.

6-50. Directed Energy Environment

A new dimension on the battlefield of the future will be the employment of directed energy devices. These may be laser, microwave, or radio frequency generated sources. Medical management of casualties from these sources will compound the already overloaded medical treatment resources. Medical management of DE patients at the BAS will consist of evaluation, application of eye ointment, patching, and evacuation. Injuries from microwave and radio frequency sources will be discussed in other publications as data becomes available. Refer to FM 8-50 for additional information on prevention and medical management of laser injuries.

6-51. Special Operations

Possible enemy employment of NBC weapons in the extremes of climate or terrain warrants additional consideration. Consideration must include the peculiarities of urban terrain, mountain, snow and extreme cold, jungle, and desert operations in an NBC environment; also the NBC-related effects upon medical treatment and evacuation. For a more detailed discussion on NBC aspects of urban terrain, mountain, snow and extreme cold, jungle, and desert operations see FM 90-10, FM 90-10-1, FM 90-6, FM 31-71, FM 90-5 and FM 90-3.

a. *Mountain Operations.* In mountain operations, units may be widely dispersed. Close-terrain may limit concentrations of troops, fewer

targets may exist; therefore, a lower patient load may be anticipated. Logistical problems, including medical evacuation, will increase. Health service support resources are spread over a wide area. Mountain passes and gorges may tend to canalize nuclear blast and clouds of chemical and biological agents. Ridges and steep slopes may offer some shielding from thermal radiation effects. Roads and railways may be nonexistent or of limited use, thus restricting movement and complicating patient evacuation. A greater reliance on air ambulance support can be expected.

b. *Operations in Snow and Extreme Cold.* The effects of extreme cold weather combined with NBC-produced injuries have not been extensively studied. However, with traumatic injuries, cold hastens the progress of shock, providing a less favorable prognosis. Reflection of thermal radiation from snow and ice-covered areas will tend to reinforce the thermal effect. Care must be exercised when moving chemically-contaminated patients into a warm shelter. Chemical contamination on the patient’s clothing may be inapparent. When the clothing begins to warm, the chemical agent may begin to vaporize, thereby contaminating the shelter. This effect is known as “off-gassing.”

c. *Jungle Operations.* In rain forests and other jungle environments the overhead canopy will to some extent shield personnel from thermal radiation. It may ignite, however, creating the danger of forest fires and resulting in burn injuries. By eliminating sunlight, the canopy may increase the persistency effect of some chemical agents near ground level. The canopy will also provide a favorable environment for biological agents.

d. *Desert Operations.* In desert operations, troops may be widely dispersed, thus presenting less profitable targets. However, the lack of cover and concealment will mean that troops are more exposed. Smooth sand is a good reflector of both thermal and blast effects; therefore, these effects will generate an increase in injuries. High desert temperatures will reinforce the discomfort and debilitation of soldiers wearing MOPP.

6-52. Medical Evacuation in an NBCDE Environment

a. An NBCDE environment will force the unit commander to consider to what extent he will

commit evacuation assets to the contaminated area. If the battalion or TF is operating in a contaminated area, most or all of the medical platoon evacuation assets will operate there also. Efforts should be made to keep some ambulances free from contamination.

b. On the modern battlefield we have three basic modes of evacuating casualties (personnel, ground vehicles, and aircraft). Using personnel to physically carry the casualties involves a great deal of inherent stress. Cumbersome MOPP gear, added to climate, increased workloads, and the fatigue of battle, will greatly reduce personnel effectiveness. If evacuation personnel are to be sent into a radiologically contaminated area, operational exposure guidance must be established. Radiation exposure records must be maintained by the battalion NBC NCO and made available to the commander, staff, and medical platoon leader. Based on operational exposure guidance, the commander or medical platoon leader will decide which evacuation elements to send into the contaminated area. Again, every effort is made to limit the number of evacuation assets which are contaminated. Evacuation considerations should include the following:

(1) A number of ambulances will become contaminated in the course of battle. Optimize the use of resources, medical or nonmedical, which are already contaminated before employing uncontaminated resources.

(2) Once a vehicle or aircraft has entered a contaminated area, it is highly unlikely that it can be spared long enough to undergo a complete decontamination. This will depend upon the contaminant, the tempo of the battle, and the resources available to the evacuation unit. Normally, contaminated vehicles (air and ground) will be confined to dirty environments.

(3) Use ground ambulances instead of air ambulances in contaminated areas; they are more plentiful, are easier to decontaminate, and can be replaced more easily. However, this does not preclude the use of aircraft.

(4) The relative positions of the contaminated area, FLOT, and Threat air defense systems will determine where helicopters may be

used in the evacuation process. One or more helicopters may be restricted to contaminated areas; with ground vehicles being used to cross the line separating contaminated and clean areas. The ground ambulance proceeds to a decontamination station; the patient is decontaminated; then a clean ground or air ambulance is used, if further evacuation is required. The routes used by ground vehicles to cross between contaminated and clean areas are considered dirty routes and should not be crossed by clean vehicles. The effects of wind and time upon the contaminants must be considered.

(5) The rotorwash of the helicopters must always be kept in mind when evacuating patients, especially in a contaminated environment. The intense winds will disturb the contaminants and further aggravate the condition. The aircraft must be allowed to land and reduce to flat pitch before patients are brought near. This will reduce the effects of the rotorwash. Additionally, a helicopter must not land too close to a decontamination station (especially upwind) because any trace of contaminants in the rotorwash will compromise the decontamination procedure.

c. Hasty decontamination of aircraft and ground vehicles is accomplished to minimize crew exposure. Units should include deliberate decontamination procedures in their SOPs. A sample aircraft decontamination station that may be tailored to a particular unit's needs is provided in FM 1-102 and FM 3-5.

d. Evacuation of patients must continue, even in an NBC environment. The medical platoon leader must recognize the constraints NBC operations place upon him; then plan and train to overcome these deficiencies.

NOTE

The key to mission success is detailed preplanning. A HSSPLAN must be prepared for each support mission. Ensure that the HSSPLAN is in concert with the tactical plan. Use the plan as a starting point and improve on it while providing HSS.

APPENDIX A

TRAINING PROCEDURES GUIDE

The following guide is provided to help you design effective training using the Five-P Model (planning, preparing, presenting, practicing, and performing).

A-1. Planning

- Review command guidance, unit missions, and FM 25-100.

- Review the training objective (task, conditions, and standards).

- Determine the soldiers or units to be trained.

- Determine the place and time of training.

- Determine the resources and facilities available.

- Consult training references.

- Review coordinating instructions and special considerations.

- Use backward planning.

- Determine what, where, how, and when the training will take place.

- List all necessary actions to prepare for training.

- Estimate the time needed for each action.

- Arrange the necessary actions in reverse order, beginning with the last action and working back to the first.

- Schedule the necessary actions.

- Develop the training outline.

- Write a training statement based on the training objective.

- Develop a caution statement (personnel or equipment hazards or security classification).

- Select the presentation method (demonstration, demonstration with practice, conference, lecture, or combination of two or more).

- Address pretest, if applicable.

A-2. Preparing

- Prepare yourself.

- Know how to perform the task being trained.

- Know how to train others to perform the task.

- Prepare the soldiers.

- Identify the soldiers or units to be trained.

- Motivate the soldiers.

- Announce the training.

- Train any prerequisite tasks first.

- Prepare the equipment, facilities, and materials.

- Reserve, request, and requisition.

- Receive equipment and materials before rehearsals.

- Operate the equipment to become familiar with it and to check it for completeness and spare parts.

- Prepare the training support personnel.

- Ensure they understand their support roles.

- Ensure they know their role as evaluators.

- Ensure they are equipped and prepared to perform.

A-3. Presenting

- Provide enough information to permit practice.
- Give information that motivates.
- Present information that allows transfer of training, if applicable.
- Tell the soldiers exact task, conditions, and standard.

A-4. Practicing

- Train the tasks step by step.
 - Give the soldiers a basic knowledge of, and familiarity with, each task.
 - Build confidence.

- Train the tasks to standard.

- Improve soldier performance to meet the training objective standards.

- Use sustainment training.

- Train the tasks in realistic settings.

- Add realism to increase the challenge.

- Train to achieve time requirements.

- Use sustainment training.

A-5. Performing

- Evaluate performance with a post-training check, by sampling, by on-the-job observation, by test or evaluation by higher headquarters, or by internal evaluation.

- Record and report the results.

APPENDIX B

COMBAT LIFESAVER

B-1. Introduction

This is an introduction to the combat lifesaver and the combat lifesavers course. Direct any questions on enrollment to the Army Institute for Professional Development, Newport News, VA. Direct any questions on the subject matter content to the Commandant, Academy of Health Sciences, US Army, ATTN: HSHA-TII, Fort Sam Houston, TX 78234-6100.

B-2. Role of the Combat Lifesaver

a. The AirLand Battle doctrine was developed for a widely-dispersed, rapidly-moving battlefield. Battlefield constraints will limit the ability of medical personnel to provide immediate, far forward care. Therefore, a plan was developed to provide the needed additional care to combat soldiers. Part of this plan is the combat lifesaver.

b. The combat lifesaver is a bridge between the self-aid/buddy aid training provided all soldiers and the medical training given to the combat medic. The combat lifesaver is given additional first-aid training and training in selected medical tasks (such as initiate an intravenous infusion and provide initial care to a soldier suffering from battle fatigue).

c. The combat lifesaver is a nonmedical soldier trained to provide emergency care as a secondary mission. He does not replace the combat medic. The primary mission of the combat lifesaver is his combat mission. Normally, one member of each squad, team, or crew will be trained as a combat lifesaver. The combat lifesaver will provide care to members of his squad, team, or crew as the mission permits. When he has no combat mission to perform, the combat lifesaver may provide limited care for casualties and assist the combat medic.

B-3. Training the Combat Lifesaver

A correspondence course has been developed for training both active duty and reserve component personnel. The course is offered only in the group study mode. Classroom instruction is provided by qualified instructors selected by the battalion commander or battalion/squadron surgeon. Students who successfully complete the written and

performance tests will receive promotion points and be certified as a combat lifesaver. The course consists of student subcourse texts, student examination, and an instructor's manual.

B-4. Administering the Combat Lifesaver Course

a. Equipment and Supplies. Arrange for equipment and supplies as early as possible. The purchase of some items, such as intravenous infusion trainers and rescue breathing manikins, may be required. The local Training and Audiovisual Support Center (TASC) may have these items available. Training items will not be provided by either the Institute for Professional Development (IPD) or the Academy of Health Sciences, US Army.

b. Enrollment. Request for enrollment must be made to IPD on DA Form 145. Separate DA Forms 145 are used to enroll the students and the instructors. A roster containing the names, rank, SSN, and component of the students must be attached to the DA Form 145. Enrollment request should be sent to IPD six weeks prior to beginning the course. Information for enrollment is in DA Pamphlet 351-20.

c. Facilities. Reserve facilities well in advance. The facilities should allow clear observation of demonstrations and provide room for student practice. Handwashing devices are required.

d. Course Material. All course material will be sent from IPD. Check all material carefully. The introductory material will list the equipment needed and procedures for teaching, testing, retesting, and dropping students.

e. Preparation. Each student is issued the subcourses two weeks before classes begin. This gives the student time to study the subcourses. Students should also be provided materials such as dressings to practice tasks during the preparation time.

f. Conduct of the Course. The classroom portion of the CLS course is a 3-day program. Soldiers who successfully complete the course are certified as combat lifesavers.

g. Record of Certification. Certification of the combat lifesaver training completion is forwarded in accordance with DA PAM 351-20 for annotation on service members DA Form 2-1, items 17 and 19. Certificates of training will be issued at unit level (IPD will not issue these certificates).

h. Recertification. Recertification of each combat lifesaver must occur annually at unit level. Course material provided by IPD for the initial combat lifesaver course may be reproduced and used in recertification training/testing. It is recommended that recertification consist of both hands-on and written testing. Recertification does not require the 3-day course training. Service members must ensure that their DA Form 2-1, items 17 and 19 are updated annually, or as the recertification occurs. It is the responsibility of the S1 to ensure that personnel matters concerning the combat lifesaver program are resolved, NOT THE MEDICAL PLATOON LEADER.

i. Aidbags.

(1) Each certified combat lifesaver will be issued a combat lifesaver aidbag. The aidbag will be packed in accordance with the prescribed packing list and will be secured as a sensitive item (for example, weapon or night vision devices) at unit

level. The aidbags will be issued to the combat lifesaver only upon deployment (training or actual).

(2) It is the responsibility of each combat lifesaver to ensure that—

- His aidbag is stocked in accordance with prescribed packing list.
- All stocked items are serviceable.
- Items have not exceeded their expiration date.

(3) Stockage items for the combat lifesaver aidbag will be requested through unit supply channels, NOT THE AID STATION.

(4) Aidbag control is the commander's responsibility. Medical platoon personnel do not share this responsibility.

(5) If a combat lifesaver fails recertification, he will not be issued an aidbag.

B-5. Medical Equipment Set

The combat lifesaver medical equipment set is a CTA 8-100 item and can be requested through the DMSO.

APPENDIX C

MEDICAL INTELLIGENCE**C-1. Modern Warfare and the Medical Threat**

The characteristics of modern warfare that define the medical threat include the following

a. Significant increases in wounded casualties beyond the capability of the HSS system to provide timely medical care.

b. Enemy combat operations in friendly rear areas interdicting lines of communication and disrupting vital combat support and combat service support activities. This will seriously impact on the ability of HSS personnel to retrieve and evacuate wounded, sick, and injured soldiers and provide them timely medical care.

c. Prolonged periods of intense, continuous operations under all types of conditions that tax soldiers to the limits of their physiological and emotional endurance.

d. Premeditated attack upon medical organizations, personnel, or Class VIII, medical materiel; although this action is not currently anticipated, it may occur. Also, a steady erosion of battlefield medical resources will result from—

- The level of combat intensity, heavy use of supplies, and the ever-increasing range of indirect fire weapons.
- The enhanced lethality, wounding capability, and destructive properties of munitions.
- The collateral and residual effects of conventional, nuclear, biological, and/or chemical weapons.
- The actions of terrorists (individuals or groups) directed against defenseless targets, especially to hospitals and medical facilities.

e. Infectious diseases that pose a major threat to combat forces. These may be in the form of naturally occurring endemic diseases or diseases introduced as a biological weapon.

f. Environmental factors such as extremes in temperature and altitude and the presence of poisonous animals, plants, and insects. These are

important considerations as causative agents of disease and injury casualties.

g. Application of advanced technologies to enhance existing weapons and munitions and the development of new weapon systems. These may provide the health service support system with new diagnostic and treatment challenges. Excellent examples of technology driven developments that we may confront include—

- Engineered biochemical compounds used as biological warfare agents.
- Genetically engineered micro-organisms used as biological warfare agents.
- Directed energy weapons consisting of high- and low-energy lasers and high-energy microwave, radio frequency, and particle weapons.
- Enhanced blast effect weapons used against personnel.
- New flame and incendiary compounds and munitions.
- Enhanced nuclear weapons with increased lethality from radiation.
- Possible mind-altering agents.

C-2. Aspects of Medical Intelligence

Medical intelligence, which is a functional area of technical intelligence, is that category of intelligence resulting from the collection, evaluation, analysis, and interpretation of foreign medical, biotechnological, and environmental information. See FM 8-10-8 for specific information.

C-3. The Significance of Medical Intelligence

Medical intelligence is critical to strategic and tactical planning and operations to conserve the fighting strength. It is a highly technical area which must be complete (collected, evaluated, analyzed, and interpreted) so that the end product is technically accurate and contains all required information.

a. At the strategic level, the objective of medical intelligence is to contribute to the formulation of national and international policy predicated in part on foreign military and civilian capabilities of the medical or biological scientific community.

b. At the tactical level, the objective of medical intelligence is to provide intelligence evaluation and analyses of the following factors in the theater:

- Conditions concerning people or animals.
- Epidemiological information (incidence, distribution, and control of infectious diseases).
- Plants.
- Enemy's field health service support.
- New weapons systems or employment methods that could alter health service support planning factors.
- Medical implications of contamination from NBC weapons based on

employment tactics and chemical or biological agents used.

- Antidotes to protect against the nuclear, biological, or chemical threat.
- Weather and/or terrain implications.

Medical intelligence also assists in identifying captured enemy materiel and equipment and how it can be used in treating enemy prisoners of war (EPW).

C-4. Integrating Medical Intelligence

If medical intelligence confirms or reveals a new threat based on the types of wounds or the types of diseases being treated, the appropriate medical staff officer advises the tactical commander. Tactical planners can use this information to counter these threats, and HSS planners can use the intelligence to develop HSS responsive to the demands of the area of operations. See FM 8-10-8 for a detailed discussion on how to obtain medical intelligence; how to determine medical intelligence requirements; how medical personnel report information gained through casual observation of activities in plain view of the discharge of their duties; and on the handling of captured medical materiel.

APPENDIX D

BATTALION AID STATION SPLIT TEAM OPERATIONS AND LOADING PLANS

D-1. General

This section presents one deployment option for the BAS. The concept is configured based on the BAS of an armor battalion. The deployment and configuration of your BAS may differ based on the mission, use this section only as a guideline. Your BAS should be configured to best support the unit operation plan.

D-2. Objectives of the Split Team Operation

a. To provide the option of split team organizing the BAS.

b. To increase the operational capability of the BAS.

c. To provide a means of maintaining full operational status during movement ("leap frogging" the BAS).

d. To provide the capability of maintaining a functional BAS in the event one team is destroyed or contaminated.

e. To provide a means of supporting two fronts of simultaneous enemy activity, whether in the offense, defense, or during retrograde operations.

f. To provide the capability of more effectively dispersing the BAS at an operational site.

g. To provide a means of organizing chests capable of supporting a push packet system of resupply.

h. To provide a standardized system capable of reducing learning curves associated with replacement of personnel.

D-3. Organization

The BAS is organized into an (A) element and a (B) element. Personnel, equipment, and vehicles are equally divided between the two elements in accordance with the BAS SOP.

D-4. Sets, Kits, and Outfits (SKO)

a. Where applicable, and based on TOES, SKOs are broken down into identical (A) and (B) subsets.

b. The SKOs for evacuation teams are identified by the attached unit designation (A), (B), (C), and (D).

c. SKOs are functionally subdivided into two groups.

(1) Subsets capable of supporting casualties requiring ATM.

(2) Subsets capable of supporting patients reporting for sick call complaint.

D-5. Sets, Kits, and Outfits Organization

a. ATLS subsets.

(1) ATLS subset (A1 and B1).

(a) Organized as the primary chest for evaluation and treatment of trauma - related cases.

(b) Used for tailgate medical support and establishment of the BAS.

(c) Maintained on the Carrier, Command Post (M577A2).

(2) ATLS subset (A2 and B2).

(a) Organized as a resupply chest for ATLS subset (A1 and B1).

(b) Maintained on the truck, cargo, 2 1/2 ton (M35A2).

(3) ATLS subset (A3 and B3).

(a) Organized as a resupply chest for ATLS subset (A1 and B1).

(b) Maintained on the M35A2.

(4) ATLS subset (A4 and B4).

(a) Organized as a resupply chest for ATLS subset (A1 and B1).

(b) Maintained on the M35A2.

(5) ATLS subset (A5 and B5).

(a) Organized as a storage chest for Dressing, First Aid, 4 x 7 inches.

(b) Maintained on the M35A2.

(6) ATLS subset (A6 and B6).

(a) Organized as a storage chest for Bandage, Muslin, Camouflaged, 37 x 37 x 52 inches.

(b) Maintained on the M35A2.

(7) Oxygen subset (A and B).

(a) Organized as treatment chest for patients requiring oxygen therapy.

(b) Available for tailgate medical support and establishment of the BAS.

(c) Maintained on the M577A2.

(8) Intravenous (IV) subset (A1, A2, B1, and B2).

(a) Organized as treatment chest for patients requiring IV therapy.

(b) Available for tailgate medical support and establishment of the BAS.

(c) Maintained on the M577A2.

(9) Satchel (A and B).

(a) Organized for the treatment of patients requiring minor surgical procedures. Surgical instruments are further subdivided into two equal minor surgical packs.

(b) Available for tailgate medical support and establishment of the BAS.

(c) Maintained on the M577A2.

(10) Trauma bag.

(a) Organized for speed and mobility in supporting trauma patients.

(b) Each vehicle maintains one trauma bag.

(c) Each aidman maintains one trauma bag.

b. Sick call subsets.

(1) Sick call subset (A1 and B1).

(a) Organized as primary chest for evaluation and treatment of sick call complaints.

(b) Used for tailgate medical support and establishment of the BAS.

(c) Maintained on the M577A2.

(2) Sick call subset (A2 and B2).

(a) Organized as a supplemental chest for evaluation and treatment of sick call complaints.

(b) Available for tailgate medical support and establishment of the BAS.

(c) Maintained on the M577A2.

(3) Sick call subset (A3 and B3).

(a) Organized as a medical re-supply chest for sick call subset (A1 and B1).

(b) Maintained on the M35A2.

c. Other SKO/subsets.

(1) Aidman subset (A, B, C, and D).

(a) Organized for the treatment of sick call/trauma patients, by the combat medic, at the front line of own troops (FLOT).

(b) Maintained on the company carrier, personnel, armored (M113A2) evacuation vehicle.

(2) Aidman medication subset (A, B, C, and D).

(a) Organized for storage of medications used in the treatment of sick call patients.

(b) Maintained on the company M113A2 evacuation vehicle.

(c) During winter months, when there is a high probability of freezing, the subset is maintained in the garrison BAS facility until an alert notification is issued.

(3) Homestation subset (A and B).

(a) Organized for the physical support of the BAS operation.

(b) Available for tailgate medical support and establishment of the BAS.

(c) Maintained on the M577A2.

(4) Medical Equipment Set Ground Ambulance (6545-01-141-9476).

(a) Organized and packed as per standard packing list.

(b) Maintained on each M577A2 and M113A2.

(5) Medical Equipment Set, Chemical Agent Patient Treatment (6545-01-141-9469).

(a) Organized and packed as per standard packing list.

(b) Maintained on the M35A2, until required by the treatment squad.

(6) Medical Equipment Set, Chemical Agent Patient Decontamination (6545-01-176-4612).

(a) Organized and packed as per standard packing list.

(b) Maintained on the M35A2, until required by the treatment squad.

(7) Splint set (6545-00-952-6975).

(a) Organized and packed as per standard packing list.

(b) Maintained on each M577A2 and M113A2.

(8) Book set (7610-00-911-3827).

(a) Organized and packed in accordance with SB 8-75-2.

(b) Maintained on the M577A2, either the (A) or (B) element based on METT-T.

d. Sample loading plans for medical platoon vehicles are shown in Figures D-1 through D-12. Specific loading plans for your organization must be prepared based on available vehicles.

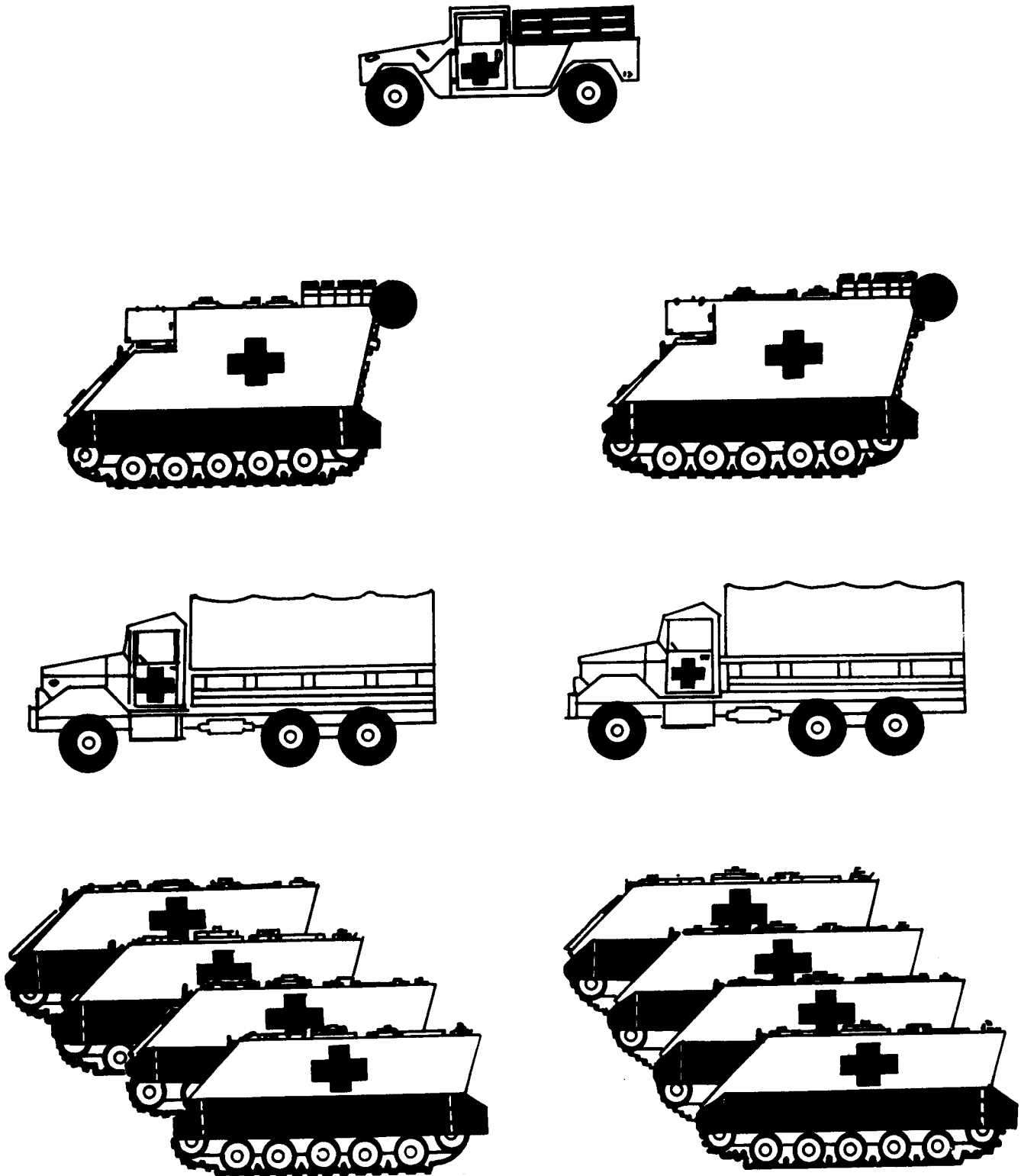

Figure D-1. Medical platoon vehicles.

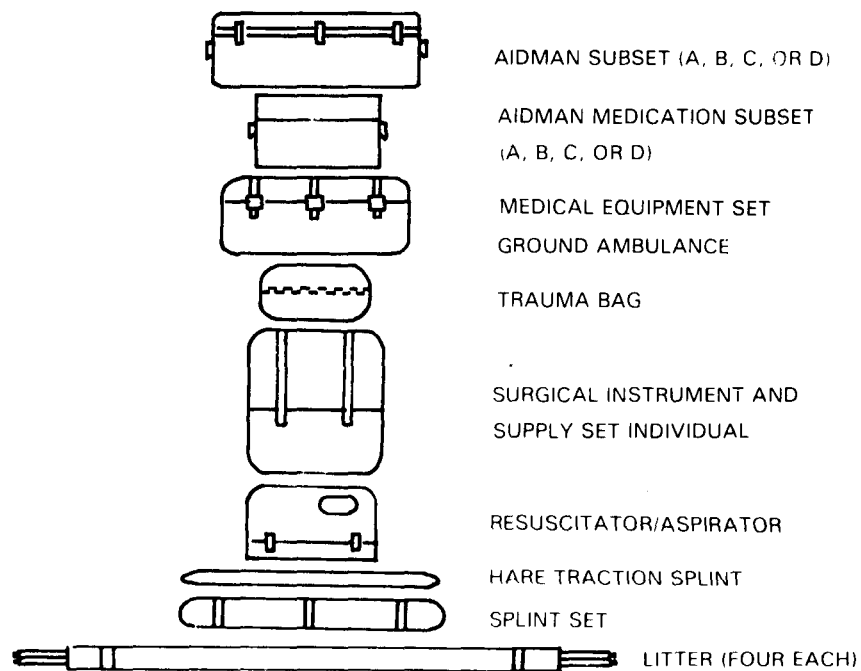
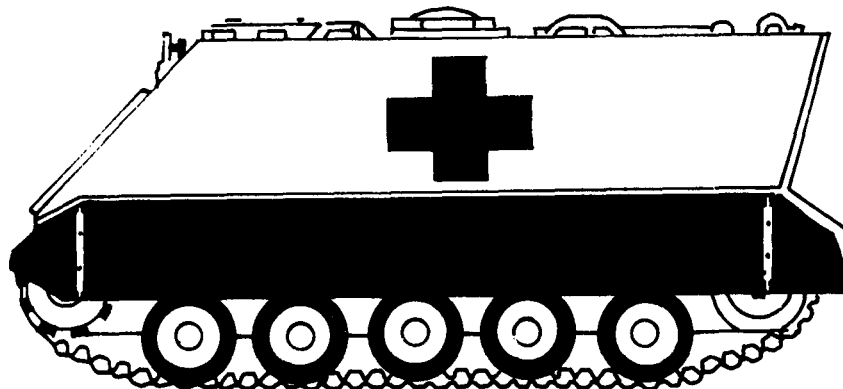

Figure D-2. M113A2 evacuation vehicles.

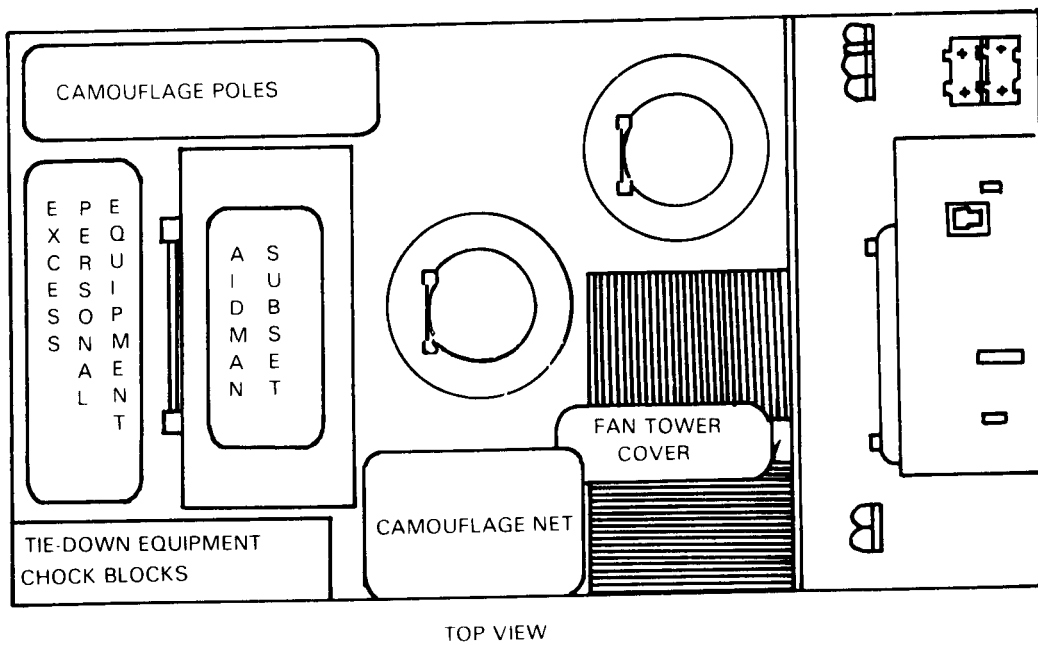
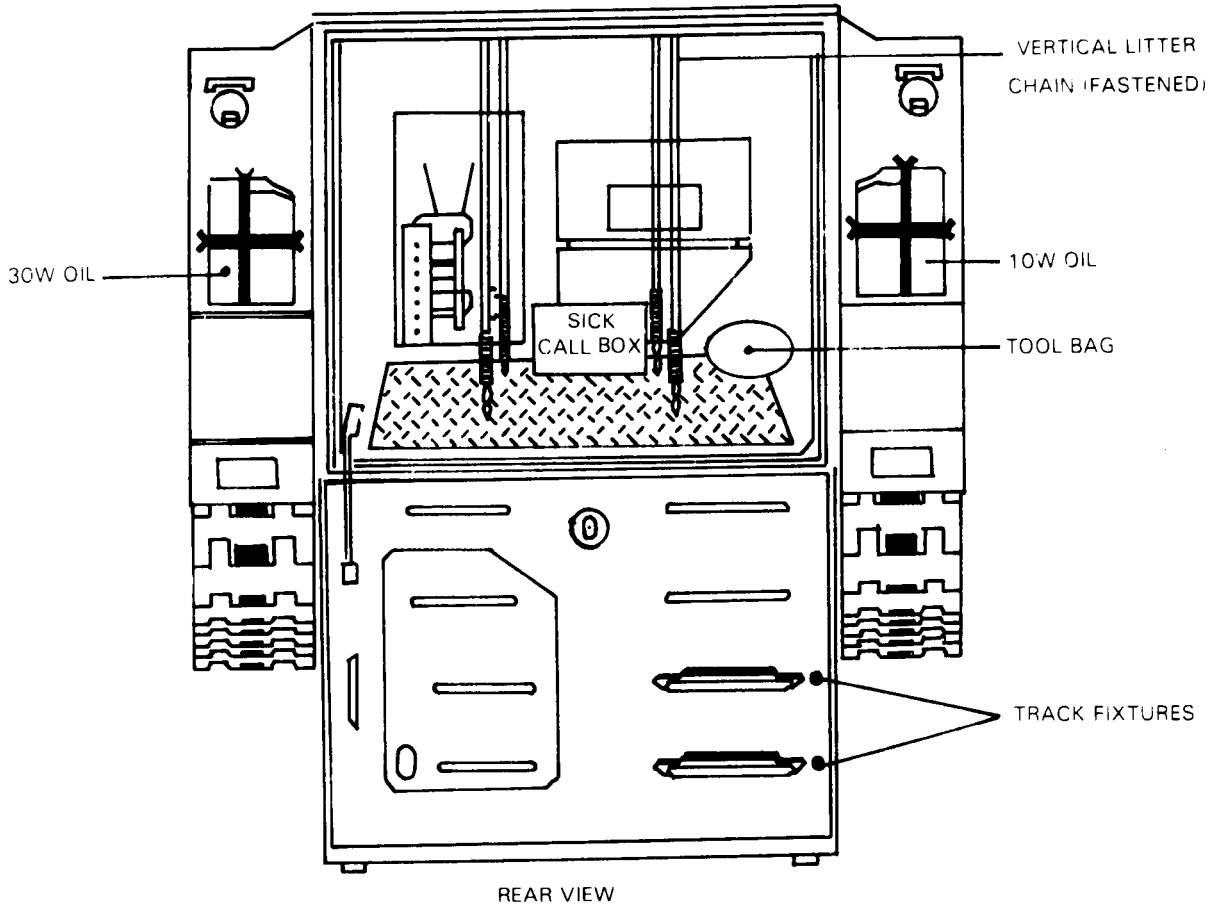
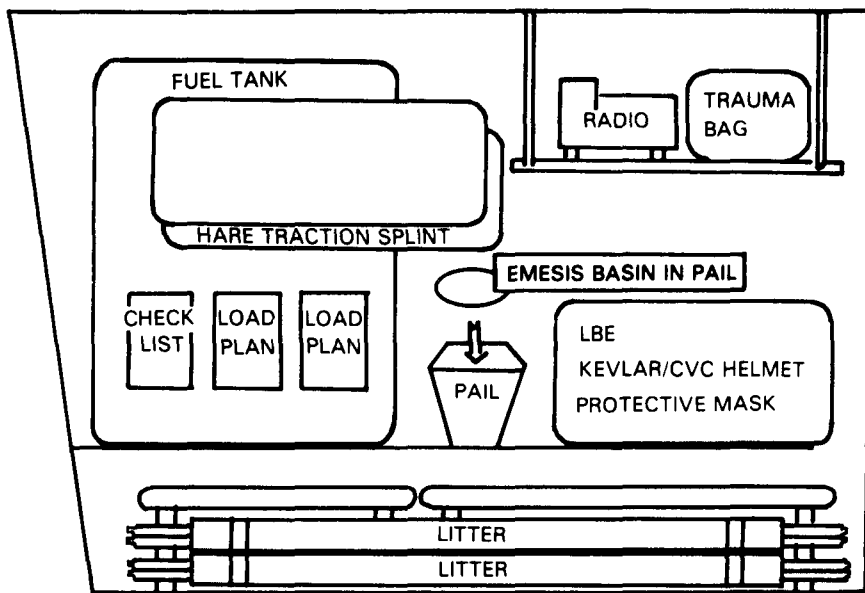
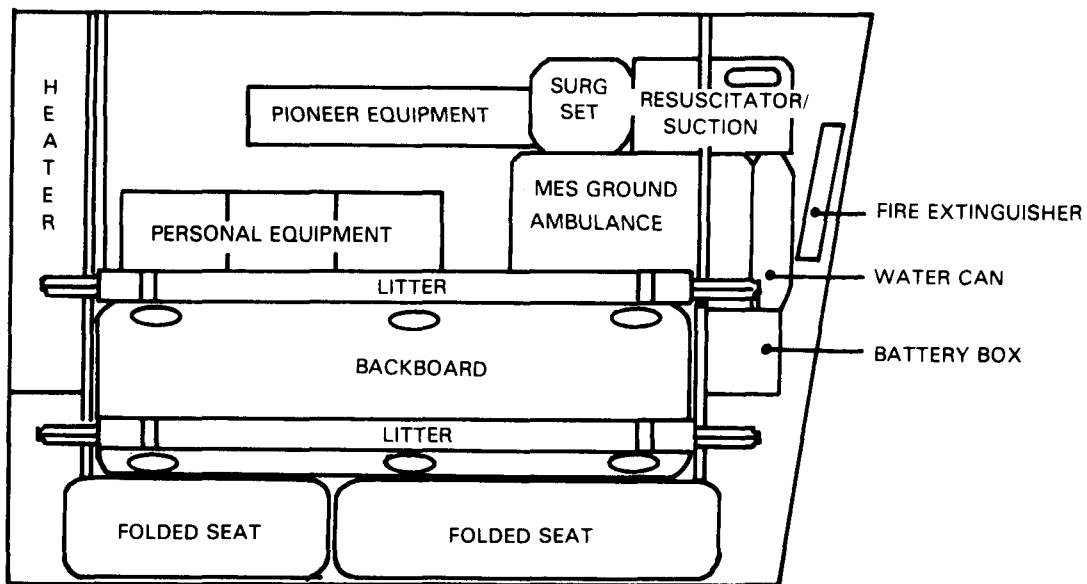

Figure D-3. M113A2 rear and top views.



LEFT SIDE



RIGHT SIDE

Figure D-4. M113A2 left and right inside views.

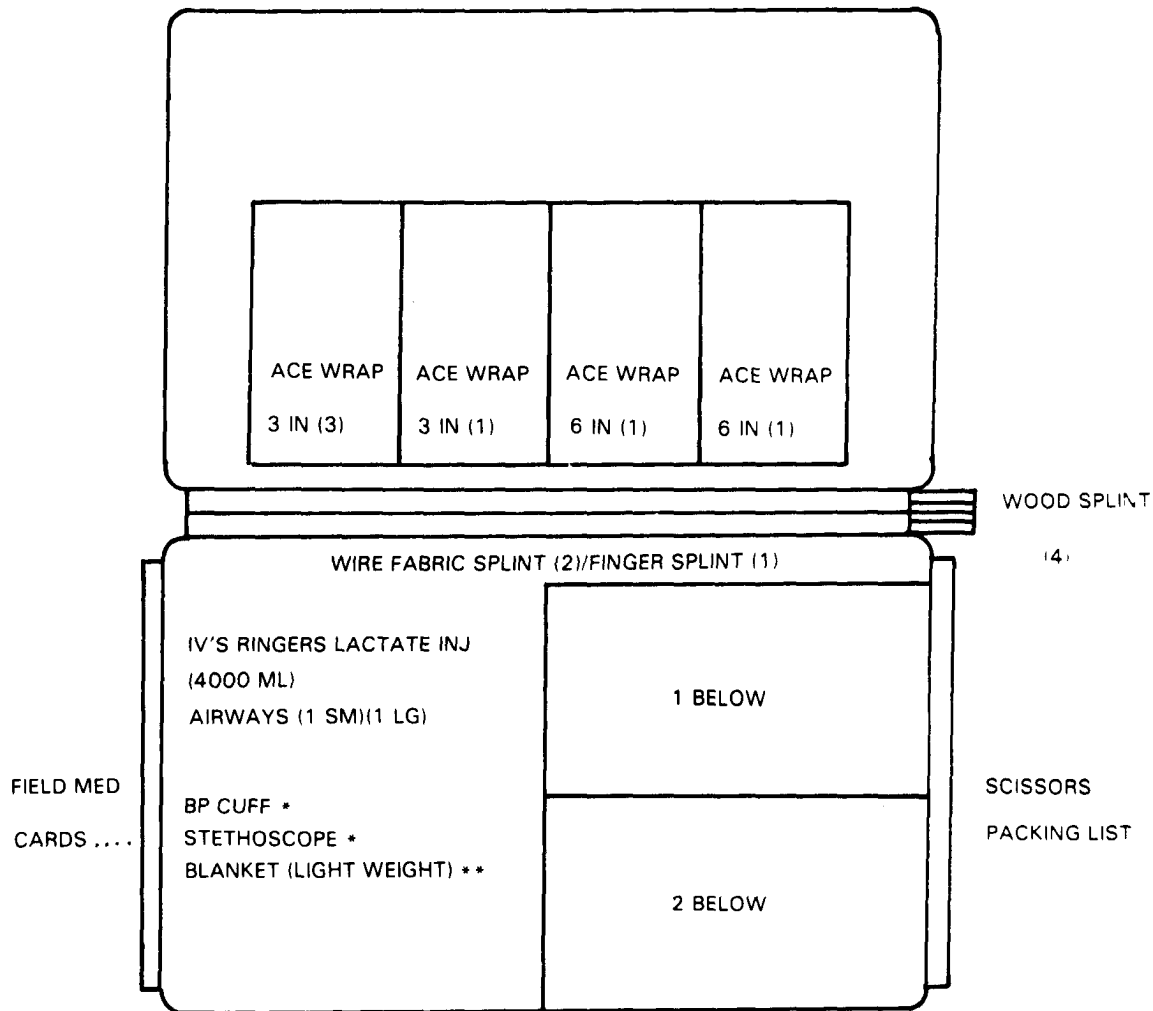

<p>1</p> <ul style="list-style-type: none"> AMMONIA INHALANTS (1 BX) EYE PADS (6) 3 IN TAPE (2) 11 3/4 IN SQ DRESSING (1) 7 1/2 X 8 IN DRESSING (2) 4 X 7 IN DRESSING (6) 4 X 4 IN SPONGES (12) PETROLATUM GUAZE (1) CRAVATS (6) 	<p>2</p> <ul style="list-style-type: none"> IV BOX IV SETS (4) 18 GA CATH NEEDLES (6) ALCOHOL PREPS (8) BETADINE (4) TAPE 1 IN X 1 1/2 YRDS (4) BAND-AIDS (12) 2 X 2 IN SPONGE (12) BETADINE PREPS (8) TOURNIQUET, RUBBER (2) TUBEX HYPODERMIC SYRINGE
---	---

* INDIVIDUAL MEDIC BAGS DO NOT CONTAIN THIS ITEM

** INDIVIDUAL MEDIC BAGS CONTAIN THIS ITEM

Figure D-5. Trauma bag contents.

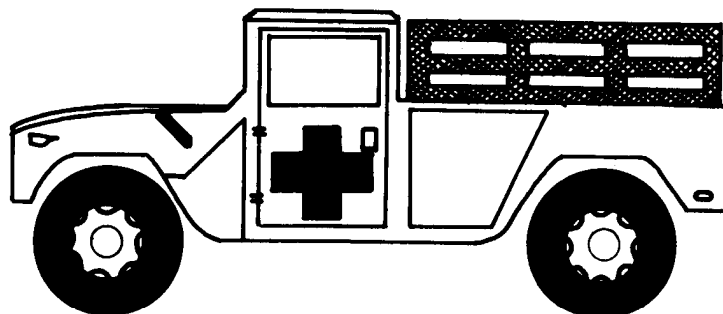

TRAUMA BAG

Figure D-6. Medical platoon headquarters vehicle, M998 HMMWV.

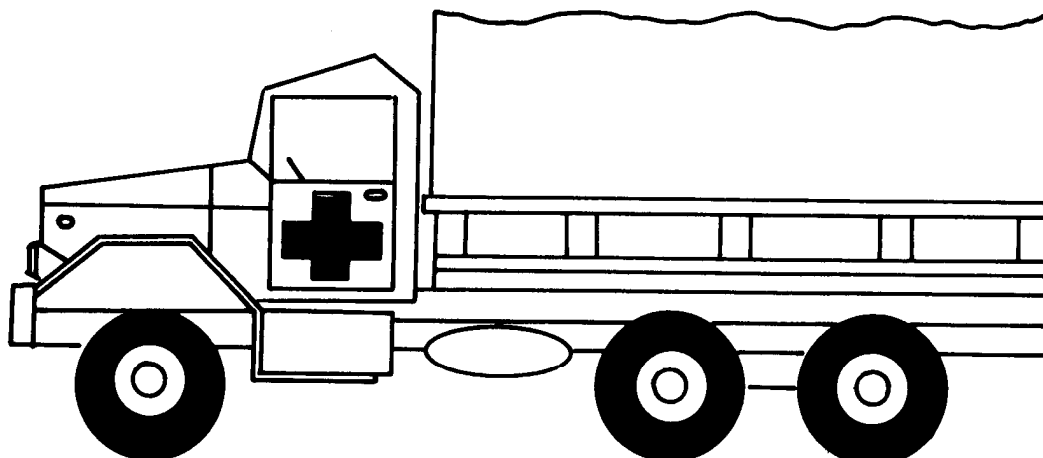

ATLS SUBSET (A2 OR B2)

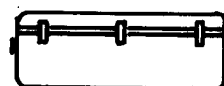

ATLS SUBSET (A3 OR B3)

ATLS SUBSET (A4 OR B4)

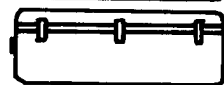
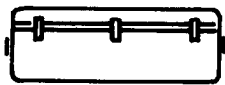

ATLS SUBSET (A5 OR B5)

ATLS SUBSET (A6 OR B6)

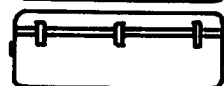
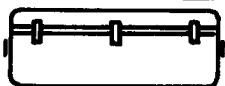

SICK CALL SUBSET (A3 OR B3)

IV SUBSET (A2 OR B2)



CHEMICAL AGENTS PATIENT TREATMENT (1 SET; EITHER A OR B ELEMENT ONLY)

CHEMICAL AGENT PATIENT DECONTAMINATION (1 SET; EITHER A OR B ELEMENT ONLY)



BOOK SET (1 SET; EITHER A OR B ELEMENT ONLY)



TRAUMA BAG

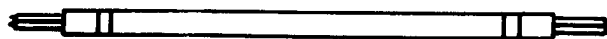

LITTERS (EXCESS)

Figure D-7. M35A2 cargo truck (2 1/2 ton).

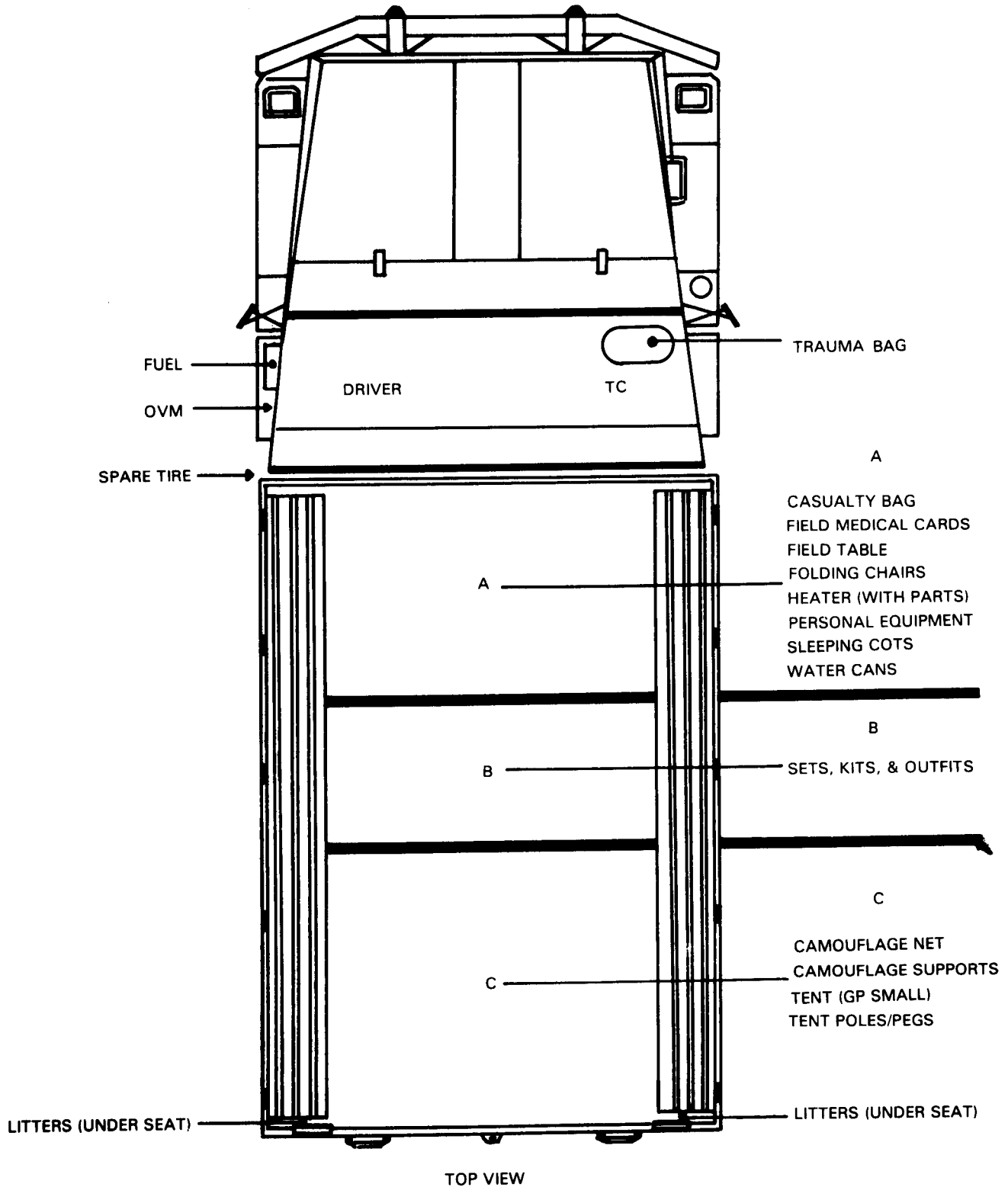

Figure D-8. M35A2 top view.

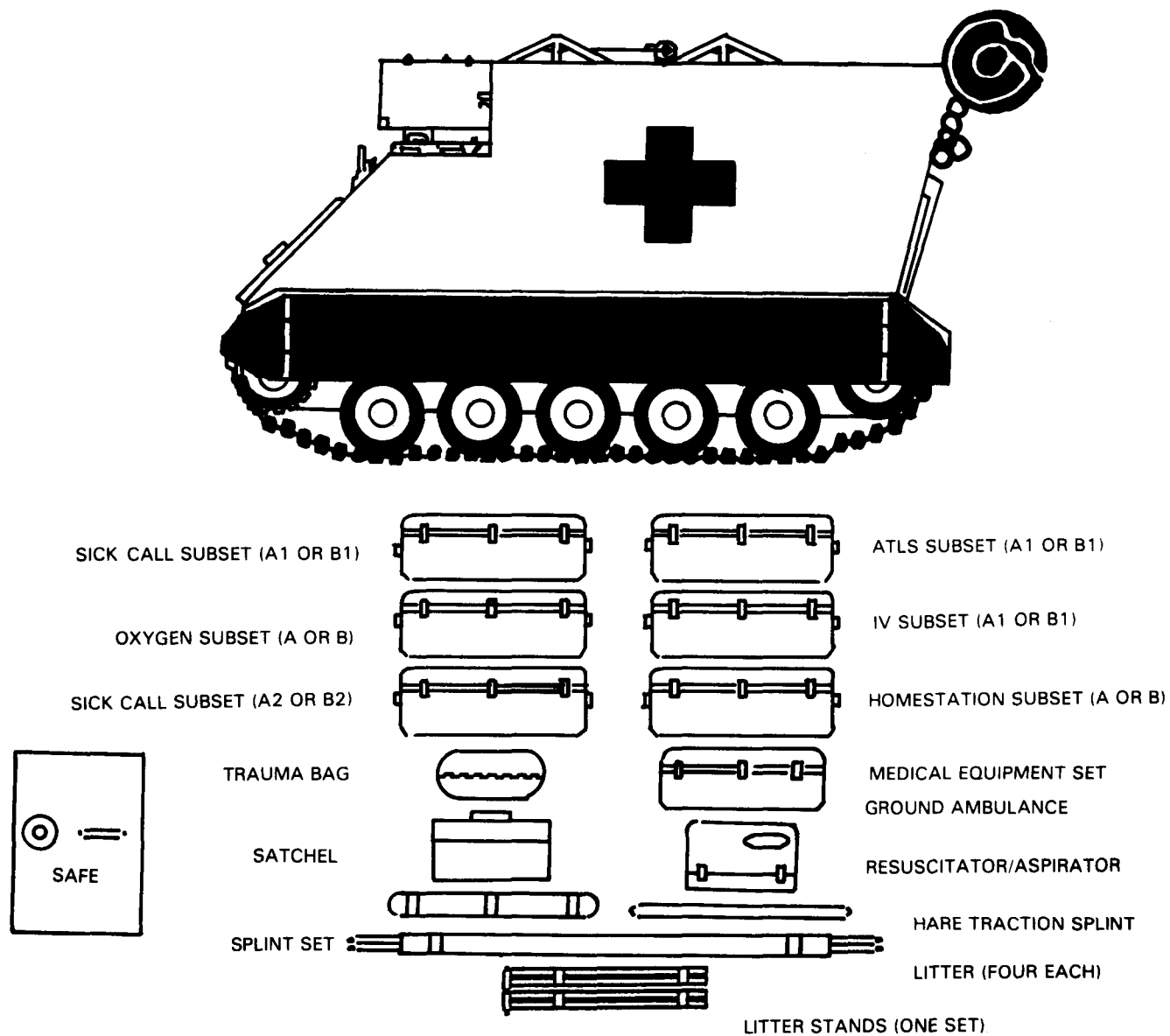
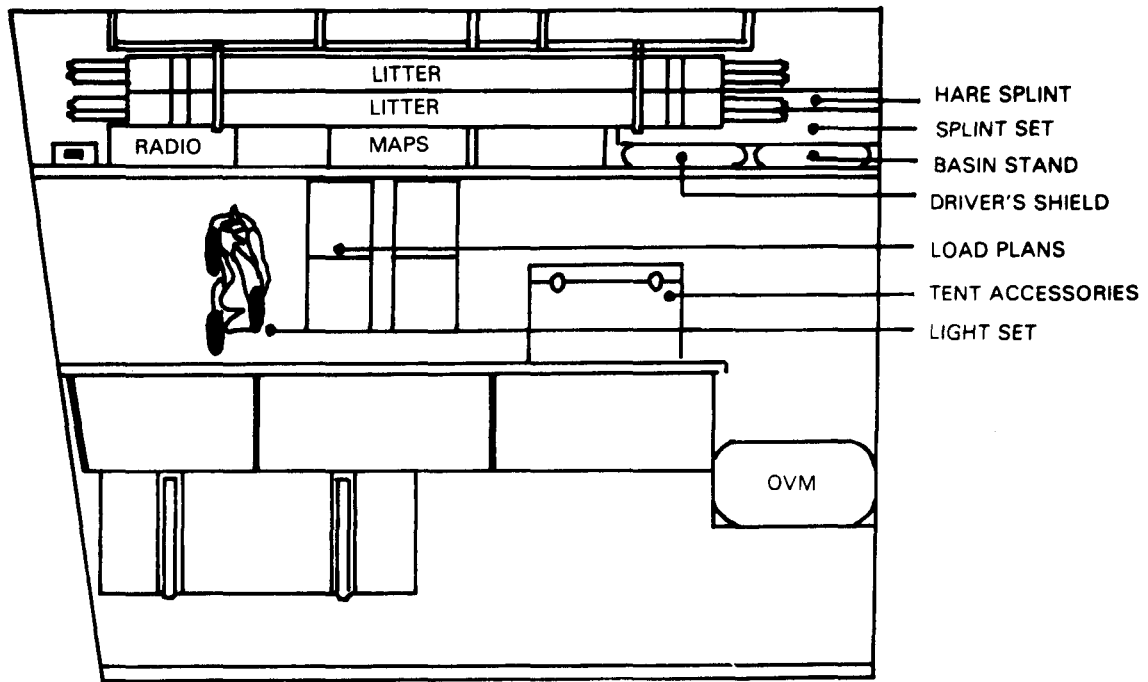
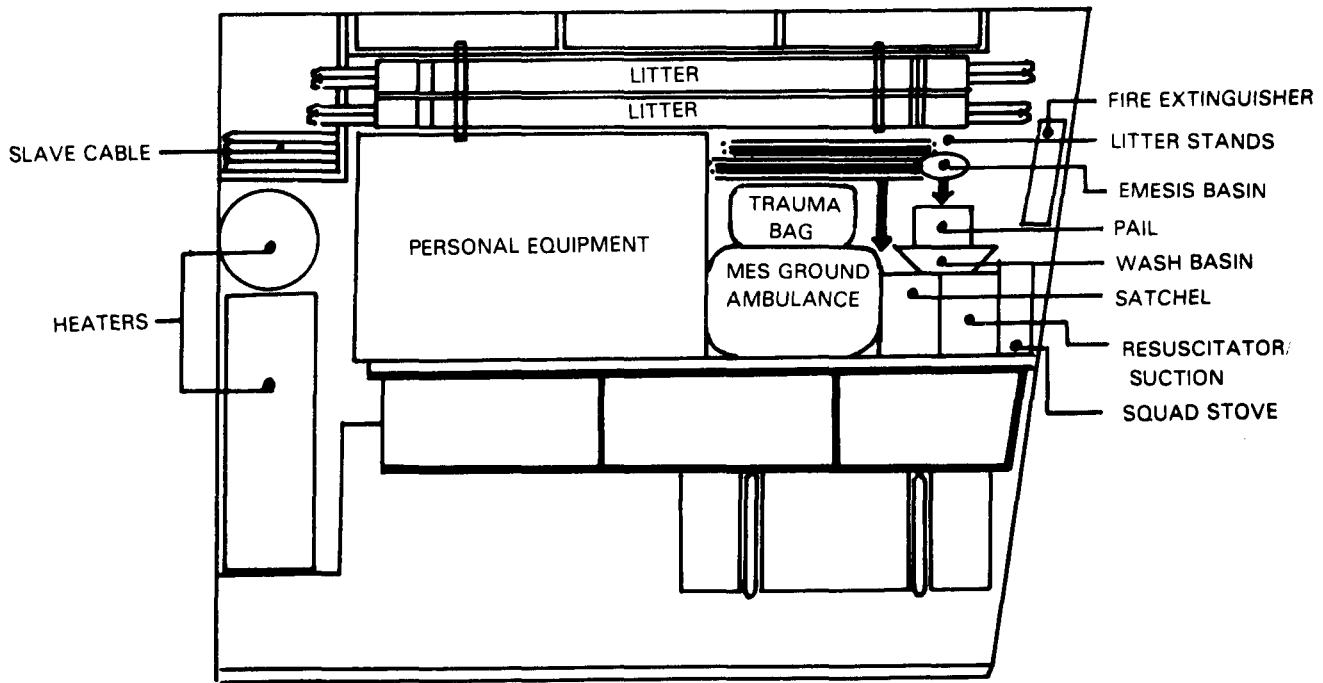

Figure D-9. M577A2 treatment team vehicle.



LEFT SIDE



RIGHT SIDE

Figure D-10. M577A2 left and right inside views.

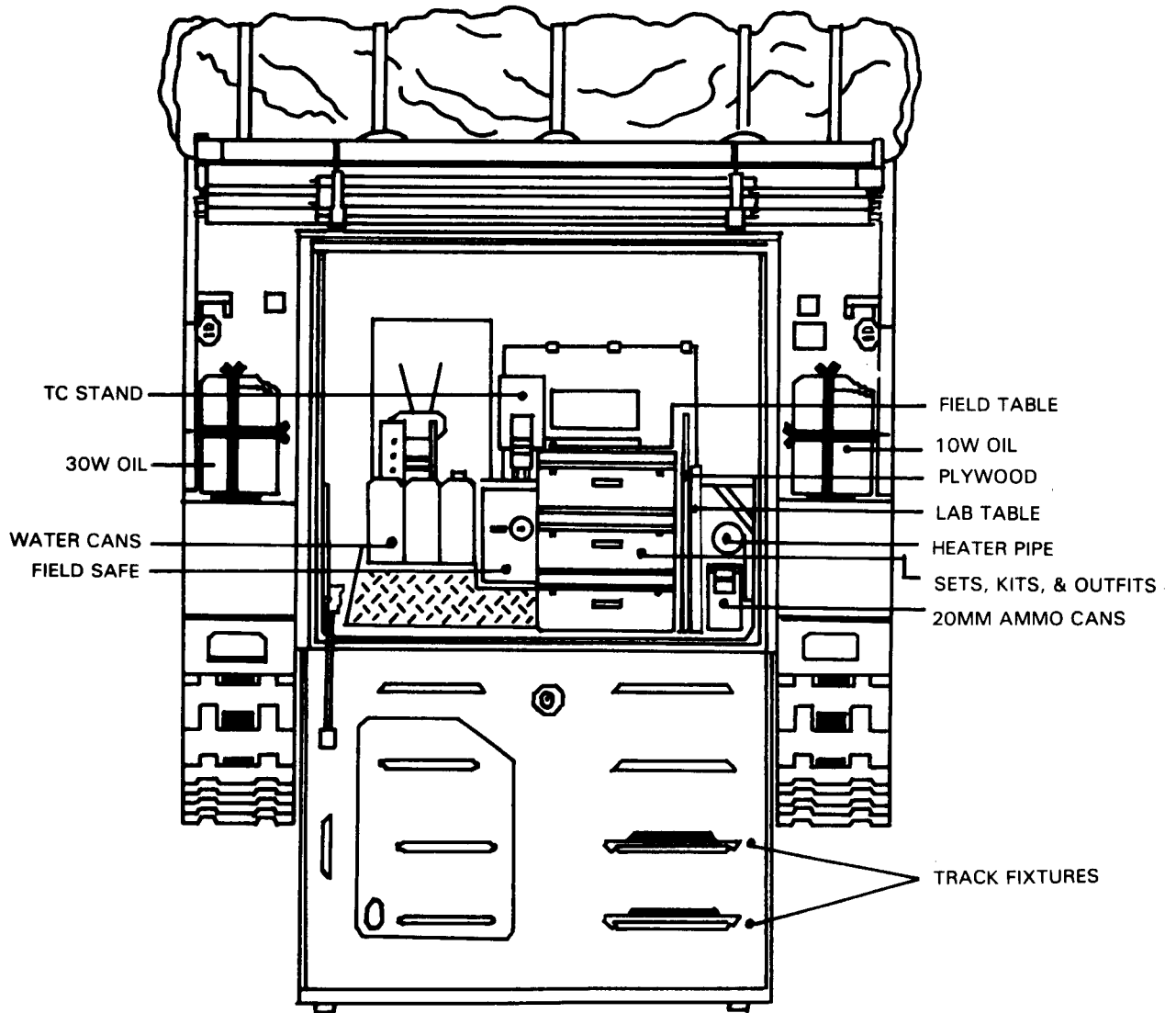

Figure D-11. M577A2 rear view.

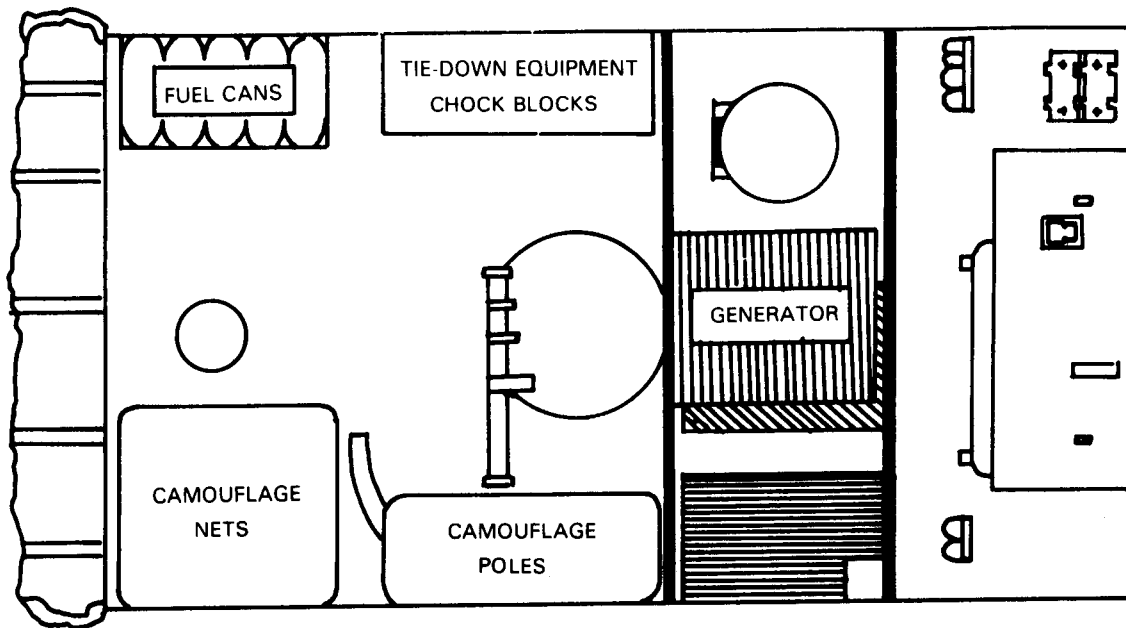

Figure D-12. M577A2 top view.

APPENDIX E

PATIENT DECONTAMINATION PROCEDURES

E-1. Decontaminate a Chemical Agent Litter Patient

Before most patients receive medical treatment, they are decontaminated by the patient decontam-

ination (decon) team. Figure E-1 presents one concept for establishment of the chemical agent patient decontamination station. The litter patient is decontaminated and undressed as follows:

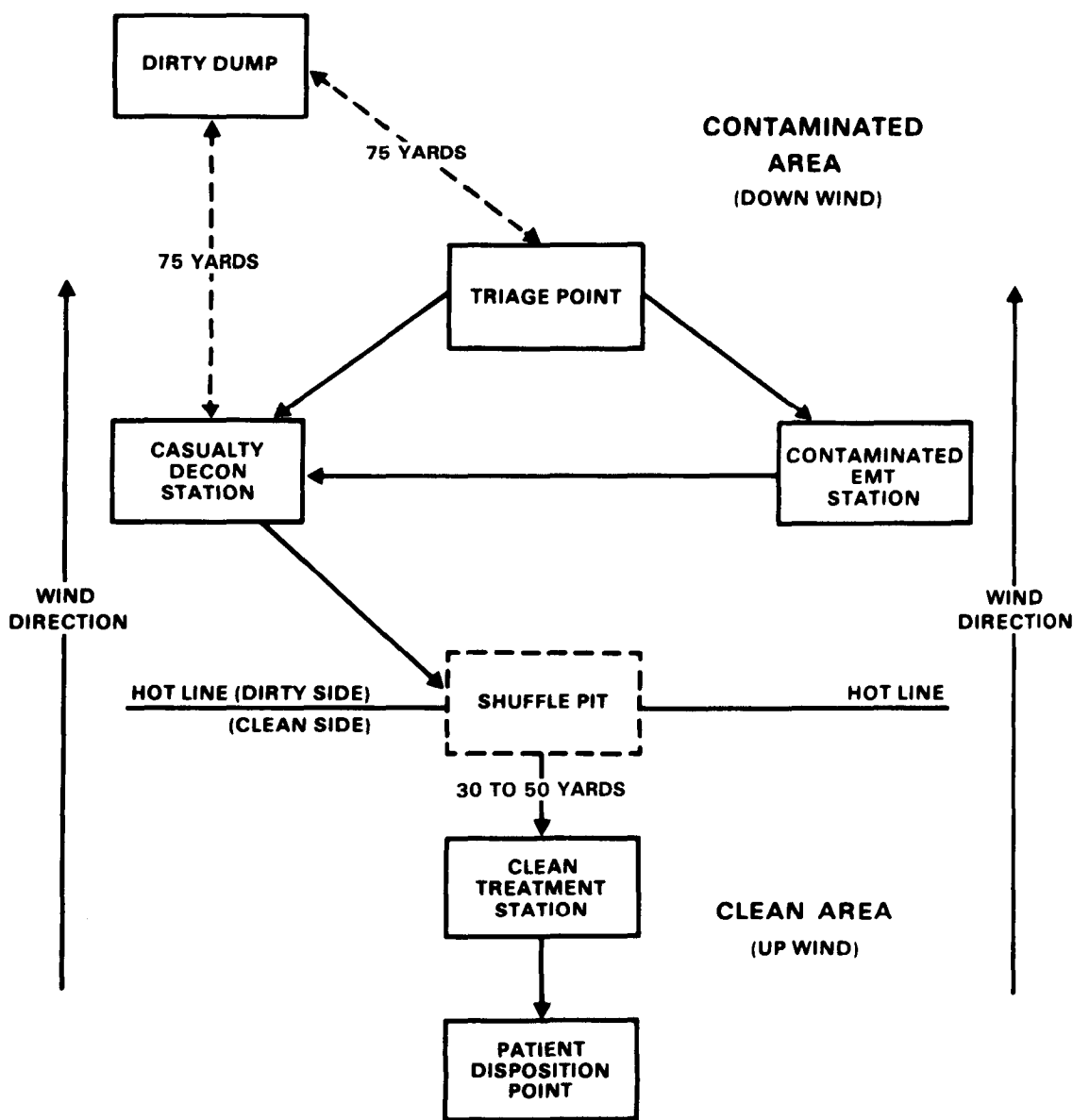

Figure E-1. Layout of a chemical agent patient decontamination station, in an uncontaminated area, without collective protective shelter.

NOTES

1. Bandage scissors are used in this procedure. They are placed in a container of 5 percent chlorine solution between each use.
2. A 5 percent chlorine solution is used to decontaminate the scissors and decontamination team member's gloves and aprons (7 heaping MRE spoonful of 70 percent calcium hypochlorite granules in 1 gallon of water). A 0.5 percent chlorine solution is used to decontaminate the patient's skin, bandages, wounds, mask, and splints (1 heaping MRE spoonful of 70 percent calcium hypochlorite granules in 1 gallon of water).
3. Use the ABC-M8VGH (M8) detector paper or the Chemical Agent Monitor (CAM) to determine the extent of contamination on each patient before beginning decontamination procedures. Some patients may have already been decontaminated.
4. For treatment procedures, refer to FM 8-9, FM 8-285, and TM 8-215.

a. Step 1: Decontaminate the patient's mask and hood.

(1) *Move the patient to the clothing removal station.* After the patient has been triaged and treated (if necessary) by the senior medic in the patient decontamination area, he is moved to the litter stands at the clothing removal station.

(2) *Decontaminate the mask and hood.* Use the M291 or M258A1 Skin Decontamination Kit; or sponge down the front, sides, and top of the mask hood with a 5 percent chlorine solution. Keep this solution off of patient's skin.

(3) *Remove the hood.* Remove the hood by cutting the M6A2 hood (see Figure E-2) or, by loosening the hood from the mask attachment points for the Quick Doff Hood or other similar hoods. Before cutting the hood, dip the scissors in a 5 percent chlorine solution. Then cut the neck cord, zipper cord, and the small string under the voice-mitter. Next, release or cut the hood shoulder straps and unzip the hood zipper. Proceed by cutting the hood upward, close to the filter inlet cover and eye lens outsert, upward to the top of the eye outsert, and across the forehead to the outer edge of the other eye lens outsert. Proceed downward toward the patient's shoulder staying close to the eye lens and filter inlet cover, then across the lower part of the voicemitter to the zipper. After dipping the scissors in the chlorine solution, cut the hood from the center of the forehead over the top of the head and fold the left and right sides of the hood to the side of the patient's head, laying the sides of the hood on the litter.

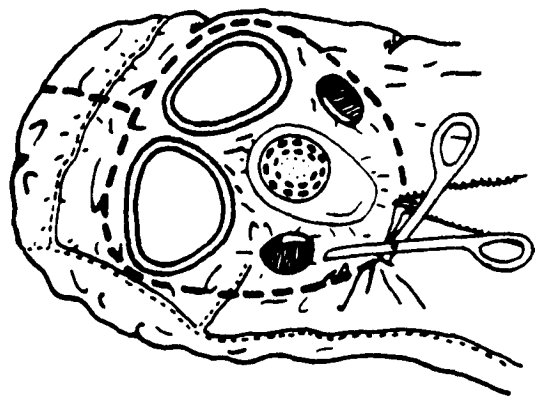

Figure E-2. Cutting M6A2 protective mask hood.

(4) *Decontaminate the protective mask and face.* Using the pads from the M291 kit, the wipes from the M258A1 kit, or a 0.5 percent chlorine solution, wipe the external parts of the mask. Cover both mask air inlets with gauze or your hand to keep the mask filters dry. Continue by wiping the exposed areas of the patients face, to include the neck, and behind the ears.

(5) *Remove the Field Medical Card.* Cut the patient's Field Medical Card (FMC) tie wire, allowing the FMC to fall into a plastic bag. Seal the

plastic bag and rinse the outside of the bag with a 0.5 percent chlorine solution. Place the plastic bag with the FMC under the back of the protective mask head straps.

b. Step 2: Remove gross contamination.

Remove all gross contamination from the patient's overgarment by wiping all visible contamination spots with a chlorine solution, M291 pads, or wipes from the M258A1 kit. Decontaminate the mask by—

- Using the M291 pad on the exterior and interior of the mask, OR
- Using the M258A1 wipe 1, then wipe 2 for the exterior of the mask; using wipe 2, then wipe 1 for the interior of the mask.

c. Step 3: Remove the patient's protective overgarment and personal effects.

(1) *Cut the patient's overgarment.* The overgarment jacket and trousers are cut simultaneously. Two persons will be cutting clothing at the same time. Cut clothing around bandages, tourniquets, and splints.

CAUTION

Bandages may have been applied to control severe bleeding, and are treated like tourniquets. Bandages, tourniquets, and splints are removed only by medical personnel.

(a) *Remove overgarment jacket.* Make two cuts, one up each sleeve from the wrist area of the sleeves, up to the armpits, and then to the collar (Figure E-3). Do not allow the gloves to touch the patient along the cut line. Dip the scissors in the 5 percent chlorine solution before making each cut to prevent contamination of the patient's uniform or underclothing. Keep the cuts close to the inside of the arms so that most of the sleeve material can be folded outward. Unzip the jacket; roll the chest sections to the respective sides with the inner surface outward. Continue by tucking the clothing between the arm and chest.

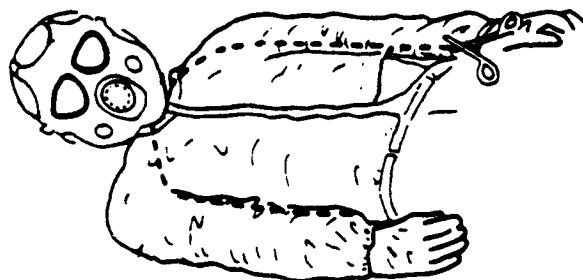

Figure E-3. Cutting the overgarment jacket.

(b) *Remove the overgarment trousers.* Cut both trouser legs starting at the ankle as shown in Figure E-4. Keep the cuts near the inseams to the crotch. With the left leg, continue cutting to the waist, avoiding the pockets. With the right leg, cut across at the crotch to and join the left leg cut. Place the scissors in the 5 percent chlorine solution. Fold the cut trouser halves away from the patient and allow the halves to drop to the litter with contaminated (green) side down. Roll the inner leg portion under and between the legs.

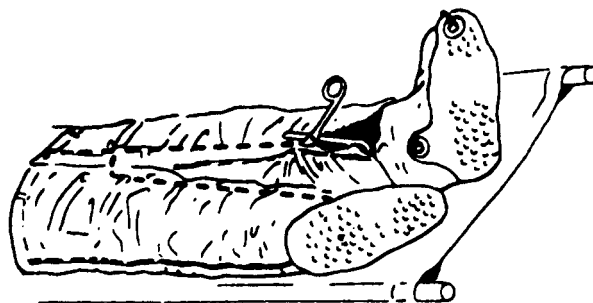

Figure E-4. Cutting the overgarment trousers.

(2) *Remove outer gloves.* This procedure can be done with one person on each side of the patient working simultaneously. If the patient's condition permits, lift his arms by grasping his gloves (Figure E-5) and roll the overgarment sleeve material away from the patient as you lift. While holding the patient's arms up, grasp the jacket material near the zipper and fold it away from the patient. Grasp the fingers of the glove, roll the cuff over the fingers, turning the glove inside out. Do not remove the inner cotton gloves at this time. Carefully lower his arms across his chest after the gloves have been removed. Do not allow the patient's arms to come into contact with

the exterior of his overgarment. Drop his gloves into the contaminated waste bag. Dip your gloves in the 5 percent chlorine solution.

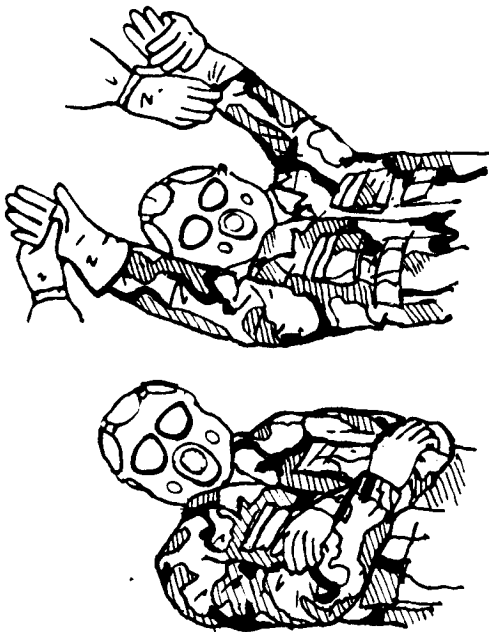

Figure E-5. Removing outer gloves and positioning arms after glove removal.

(3) *Remove the overboots.* Cut the overboot laces and fold the lacing eyelets flat outwards. If the green overboot is worn, first try to remove the overboot without cutting, if necessary, cut the boot along the front. While standing at the foot of the litter, hold the heel with one hand, pull the overboot downwards, then pull towards you to remove the overboot over the combat boot heel. If the two overboots are removed simultaneously, this will reduce the likelihood of contaminating one of the combat boots. While holding the heels off of the litter, have a decon team member wipe the end of the litter with the 5 percent chlorine solution to neutralize any liquid contamination that was transferred to the litter from the overboots. Lower the patient's heels onto the decontaminated litter. Place the overboots in the contaminated waste bag.

(4) *Remove the patient's personal effects.* Remove the patient's personal effects from his protective overgarment and battledress uniform pockets. Place the articles in a plastic bag, label

with patient's identification, and seal the bag. If the articles are not contaminated, they are returned to the patient. If the articles are contaminated, place them in the contaminated holding area until they can be decontaminated, then return them to the patient.

d. Step 4: Remove the patient's battledress uniform.

(1) *Remove the combat boots.* Cut the boot laces along the tongue. Remove the boots by pulling them towards you. Place the boots in the contaminated waste bag. Do not touch the patient's skin with contaminated gloves when removing his boots.

(2) *Remove inner clothing.* Follow the procedures for cutting away the protective overgarment and rolling it away from the patient. If the patient is wearing a brassiere, it is cut between the cups; both shoulder straps are cut where they attach to the cups and are laid back off of the shoulders. Remove the socks and cotton gloves.

e. Step 5: Transfer the patient to a decontamination litter. After the patient's clothing has been cut away, he is transferred to a decontamination litter or a canvas litter with a plastic sheeting cover. Three decontamination team members decontaminate their gloves and apron with the 5 percent chlorine solution. One member places his hands under the small of the patient's legs and thighs; a second member places his arms under the patient's back and buttocks; and the third member places his arms under the patient's shoulders and supports the head and neck. They carefully lift the patient using their knees, not their back to minimize back strain. While the patient is elevated another decon team member removes the litter from the litter stands and another member replaces it with a decontamination (clean) litter. The patient is carefully lowered onto the clean litter. Two decon members carry the litter to the skin decontamination station. The contaminated clothing and overgarments are placed in bags and moved to the decontaminated waste dump. The dirty litter is rinsed with the 5 percent decontamination solution and placed in a litter storage area. Decontaminated litters are returned by ambulance to the maneuver units.

NOTE

Before obtaining another patient, the decontamination team drinks approximately 1/2 cup of water. The amount consumed is increased or decreased according to the work level and the temperature.

f. Step 6: Skin decontamination.

(1) *Spot decontamination.* With the patient in a supine position, spot decontaminate the skin using the M291/M258A1 kit or a 0.5 percent chlorine solution. Decontaminate areas of potential contamination, particularly tears or holes in the protective ensemble; other areas include the neck, wrists, and lower parts of the face.

(2) *Aidman care.* During clothing removal, the clothing around bandages, tourniquets, and splints were cut and left in place.

(a) The aidman will replace the old tourniquet by placing a new tourniquet 1/2 to 1 inch above the old one. He will then remove the old one and the skin is decontaminated using the M291 pads, the M258A1 wipes, or the 0.5 percent chlorine solution.

(b) Usually the aidman will gently cut away bandages. The aidman decontaminates the area around the wound with the 0.5 percent chlorine solution. If bleeding begins the aidman replaces the bandage with a clean one. DO NOT use the M291 pads or wipes from the M258A1 kit around the wounds.

(c) **DO NOT remove splints.** Splints are decontaminated by applying the 0.5 percent chlorine solution to them to include the padding and cravats. Splints are not removed until the patient has been evacuated to a corps hospital. The patient is checked for completeness of decontamination by use of M8 detection paper or the CAM.

NOTE

Other monitoring devices may be used when available.

(d) Dispose of contaminated bandages and coverings by placing them in a contaminated waste bag. Seal the bag and place it in the contaminated waste dump.

g. Step 7: Transfer the patient across the shuffle pit. The patient's clothing has been cut away and his skin, bandages, and splints have been decontaminated. The litter is transferred to the shuffle pit and placed upon the litter stands. The shuffle pit is sufficiently wide enough to prevent members of the patient decon team to straddle it while carrying the litter. A third member of the decon team assists with transferring the patient to a clean treatment litter in the shuffle pit (Figure E-1).

(1) Decontamination personnel rinse or wipe down their aprons and gloves with the 5 percent chlorine solution.

(2) Three decon team members lift the patient off of the decontamination litter. One member places his arms under the small of the patient's legs and thigh; the second member places his arms under the small of the patient's back and buttocks; and the third places his arms under the patient's shoulders and supports the head and neck. They carefully lift the patient with their knees, not their back to minimize back strain.

(3) While the patient is elevated, another decon team member removes the litter from the stands and returns it to the decontamination area. A medic from the clean side of the shuffle pit replaces the litter with a clean one. The patient is lowered onto the clean litter. Two medics from the clean side of the shuffle pit move the patient to the clean treatment area. The patient is treated in this area or awaits processing into the collective protective shelter. The litter is wiped down with the 5 percent chlorine solution in preparation for reuse.

NOTE

Before decontaminating another patient, each decon team member drinks approximately 1/2 cup of water. The exact amount of water consumed is increased or decreased according to the work level and temperature (see Figure E-6).

*CRITERIA		CONTROLS		
Heat Condition/Category	WBGT Index °F	Water Intake Quart/Hour	Physical Activity for Soldiers	
			** Acclimatized Work/Rest	Unacclimatized Soldiers and Trainees
White/ 1	78-81.9	At least ½	Continuous	
Green/ 2	82-84.9	At least ½	50/10 minutes	Use discretion in planning heavy exercises.
Yellow/ 3	85-87.9	At least 1	45/15 minutes	Suspend strenuous exercise during first three weeks of training. Training activities may be continued on a reduced scale after the second week of training. Avoid activity in direct sun.
Red/ 4	88-89.9	At least 1 ½	30/30 minutes	Curtail strenuous exercise for all personnel with less than 12 weeks of hot weather training.
Black/ 5	90 and up	More than 2	20/40 minutes	Physical training and strenuous exercise is suspended. Essential operational commitments not for training, where risk of heat casualties may be warranted, is excluded from suspension. Enforce water intake to minimize expected heat injuries.

* MOPP gear or body armor adds 10 °F to the WBGT index.

** An acclimatized soldier is one who has worked in the given heat condition for 10 to 14 days.

NOTE: "Rest" means minimal physical activity. Rest should be accomplished in the shade if possible. Any activity requiring only minimal physical activity can be performed during "rest" periods. EXAMPLES: Training by lecture or demonstration, minor maintenance procedures on vehicles or weapons, personal hygiene activities, such as skin and foot care.

Figure E-6. Heat injury prevention and water consumption.

E-2. Decontaminate an Ambulatory Chemical Agent Patient

All ambulatory patients will not be completely decontaminated at the battalion aid station. Stable patients not requiring treatment at the BAS, but requiring evacuation to the division clearing station or a corps hospital for treatment may be evacuated in his protective overgarments and mask by any available transportation; such as a patient with a broken arm. However, before evacuation, spot removal of all thickened agents from his protective clothing will be accomplished. For ambulatory patients requiring treatment at the BAS, complete decontamination will be accomplished. A member of the decontamination team or other ambulatory patients will assist in the clothing removal and skin decontamination of these patients. Bandage scissors are used in this procedure; they are returned to the container of 5 percent chlorine solution when not in use.

NOTES

1. Most ambulatory patients will be treated in the contaminated treatment area and returned to duty.
2. Upon removal of an ambulatory patient's clothing, he becomes a litter patient. The BAS and DCS do not have clothing to replace those cut off during the decontamination process. The patient must be placed in a patient protective wrap (PPW) for protection during evacuation.

a. *Step 1: Remove load bearing equipment.* Remove the load bearing equipment (LBE) by unfastening/unbuttoning all connectors or tie

straps; then place the LBE into a plastic bag. Place the plastic bag in the designated storage area.

b. Step 2: Decontaminate the patient's mask and hood.

(1) *Send patient to clothing removal station.* After the patient has been triaged and treated (if necessary) by the senior medic in the patient decontamination station he walks to the clothing removal station.

(2) *Decontaminate and remove mask hood.*

(a) Sponge down the front, sides, and top of the hood with a 5 percent chlorine solution. Keep this solution off of the patient's skin. Remove the hood by cutting the M6A2 hood (Figure E-2) or where possible with the Quick Doff Hood or other hoods, by loosening the hood from the mask attachment points. Before cutting the hood, dip the scissors in the 5 percent chlorine solution. Begin by cutting the neck cord, zipper cord, and the small string under the voicemitter. Next, release or cut the hood shoulder straps and unzip the hood zipper. Proceed by cutting the hood upward, close to the filter inlet cover and eye outserts, to the top of the eye outsert, across the forehead to the outer edge of the next eye outsert. Proceed downward toward the patient's shoulder staying close to the eye lens and filter inlet, then across the lower part of the voicemitter to the zipper. After dipping the scissors in the 5 percent chlorine solution again, cut the hood from the center of the forehead over the top of the head and fold the right and right sides of the hood away from the patient's head, removing the hood.

(b) Decontaminate the protective mask and patient's face by using the pads from the M291 kit, the wipes from the M258A1 kit, or the 0.5 percent chlorine solution. Wipe the external parts of the mask, cover both mask air inlets with gauze or your hands to keep the mask filters dry. Continue by wiping the exposed areas of the patient's face, to include the neck and behind the ears.

c. Step 3: Remove the Field Medical Card. Cut the FMC tie wire, allowing the FMC to fall into a plastic bag. Seal the plastic bag and rinse it with the 0.5 percent chlorine solution. Place the plastic bag under the back of the protective mask head straps.

d. Step 4: Remove all gross contamination from the patient's overgarment. Remove all visible contamination spots by using the pads from the M291 kit, the wipes from the M258A1 kit, or a sponge with the 5 percent chlorine solution.

e. Step 5: Remove overgarments.

(1) *Remove overgarment jacket.*

(a) Have the patient stand with his feet spread apart at shoulder width. Unsnap the jacket front flap and unzip the jacket. If the patient can extend his arms, have him clinch his fist and extend his arms backward at about a 30 degree angle. Move behind the patient, grasping his jacket collar at the sides of the neck, peel the jacket off the shoulders at a 30 degree angle down and away from the patient. Avoid any rapid or sharp jerks which spread contamination; gently pull the inside sleeves over the patient's wrists and hands.

(b) If the patient cannot extend his arms, you must cut the jacket to aid in its removal. Dip the scissors in the 5 percent chlorine solution between each cut. As with the litter patient, cut both sleeves from the inside starting at the wrist up to the armpit. Continue cutting across the shoulder to the collar. Cut around bandages or splints, leaving them in place. Next, peel the jacket back and downward to avoid spreading contamination. Ensure that the outside of the jacket does not touch the patient or his inner clothing.

(c) Remove the patient's butyl rubber gloves by grasping the heel of the glove, peel the glove off with a smooth downward motion. Place the contaminated gloves in a plastic bag with the overgarment jacket. Do not allow the patient to touch his trousers or other contaminated object with his exposed hands.

(2) *Remove the patient's overboots.* Remove the patient's overboots by cutting the laces with scissors dipped in the 5 percent chlorine solution; fold the lacing eyelets flat on the ground. Step on the toe and heel eyelets to hold the overboot on the ground and have the patient step out of it. Repeat this procedure for the other overboot. If the overboots are in good condition, they can be decontaminated and reissued.

(3) *Remove overgarment trousers.*

(a) Unfasten or cut all ties, buttons, or zippers before grasping the trousers at the waist and peeling them down over the patient's combat boots. Again, the trousers are cut to aid in removal. If necessary, cut both trouser legs starting at the ankle, keep the cuts near the inside of the legs, along the inseam, to the crotch. Cut around all bandages, tourniquets, or splints. Continue to cut up both sides of the zipper to the waist and allow the narrow strip with the zipper to drop between the legs. Place the scissors in the decontamination solution. Peel or allow the trouser halves to drop to the ground. Have the patient step out of the trouser legs one at a time. Place the trousers in the contaminated disposal bag.

(b) Have the patient remove his cotton glove liners to reduce the possibility of spreading contamination. Have the patient grasp the heel of one glove liner with the other gloved hand; peel the glove off of his hand. Hold the removed glove by the inside and grasp the heel of the other glove, peeling it off of his hand. Place both gloves in the contaminated waste bag.

(c) Place the patient's personal effects in a clean bag and label with the patient's identification. If they are not contaminated, give them to him. If his personal effects are contaminated, place the bagged items in the contaminated storage area until they can be decontaminated, then return them to the patient.

f. Step 6: Check patient for contamination. After the patient's overgarments have been removed, check his battledress uniform by using M8 detection paper or the CAM. Carefully survey all areas of the patient's clothing, paying particular attention to discolored areas on the uniform, damp spots, tears, and areas around the neck, wrist, ears, and dressings, splints, or tourniquets. Remove spots by using the 0.5 percent chlorine solution, using the pads from the M291 kit, or the wipes from the M258A1 kit or cutting away the contaminated area. Always dip the scissors in the 5 percent chlorine solution after each cut. Recheck the area with the detection material.

g. Step 7: Decontaminate the patient's skin.

(1) Use the pads from the M291 kit, the wipes from the M258A1 kit, or the 0.5 percent chlorine solution to spot decontaminate exposed neck and wrist areas, other areas where the protective overgarment was damaged, dressings, bandages, or splints.

(2) Have the patient hold his breath and close his eyes. Have him or assist him in lifting his mask at the chin. Wipe his face quickly from below the top of one ear being careful to wipe all folds of the skin, top of the upper lip, chin, dimples, ear lobes, and nose, up the other side of the face to the top of the other ear. Wipe the inside of the mask where it touches the face. Have the patient reseal and check his mask.

CAUTION

Keep the decontamination solution out the patient's eyes and mouth.

h. Step 8: Remove bandages and tourniquets. During the clothing removal, the clothing around bandages, tourniquets, and splints was cut and left in place.

(1) The aidman will replace the old tourniquet by placing a new one 1/2 to 1 inch above the old tourniquet. When the old tourniquet is removed, the skin is decontaminated with the M291 pads, the M258A1 wipes, or the 0.5 percent chlorine solution.

(2) Do not remove splints. Decontaminate them by thoroughly rinsing the splint, padding, and cravats with the 0.5 percent chlorine solution.

(3) The aidman gently cuts away bandages. The area around the wound is rinsed with the 0.5 percent chlorine solution, and the aidman irrigates the wound with the 0.5 percent chlorine solution. The aidman covers massive wounds with plastic secured with tape. Mark the wound as contaminated. The aidman also replaces bandages that are needed to control massive bleeding.

(4) Dispose of contaminated bandages and coverings by placing them in a plastic bag and

sealing the bag with tape. Place the plastic bags in the contaminated waste dump,

i. Step 9: Proceed through the shuffle pit to the clean treatment area. Have the decontaminated patient proceed through the shuffle pit to the clean treatment area. Make sure that the patient's boots are well decontaminated by stirring the contents of the shuffle pit as he crosses it.

E-3. Decontaminate Biological Agent-Contaminated Patients

The decontamination station as established for chemical agent patients can also be used for biologically contaminated patients. The 8-man patient decontamination team is required for biologically contaminated patient decontamination procedures.

E-4. Decontaminate Biological Agent-Contaminated Litter Patient

a. Remove the FMC by cutting the tie wire and allowing the FMC to drop into a plastic bag. Keep the FMC with the patient.

b. Patient decontamination team members first apply a liquid disinfectant, such as chlorine dioxide, to the patient's clothing and the litter.

NOTE

Disinfectant solution for use in patient decontamination procedures must be prepared in accordance with the label instructions on the container. The strength of solution for use on the skin can also be used to irrigate the wound.

c. Patient decontamination team members remove the patient's clothing as in decontamination of chemical agent patients. Bandages, tourniquets, and splints are not removed. Move patient to a clean litter as described for a chemical agent patient. Place patient's personal effects in a clean plastic

bag label the bag. If uncontaminated, give to patient. If contaminated, place in contaminated storage, decontaminate when possible, then return to patient. Place patient's clothing in a plastic bag and dispose in a contaminated waste dump.

d. Bathe patient with soap and warm water, followed by reapplication of a liquid disinfectant. The medic places a new tourniquet 1/2 to 1 inch above the old tourniquet, then he removes the old one. The medic removes bandages and decontaminates the skin and wound with the disinfectant solution or the 0.5 percent chlorine solution; he replaces the bandage if needed to control bleeding. Splints are disinfected by soaking the splint, cravats, and straps with the disinfectant solution.

NOTE

Use a 0.5 percent chlorine solution to decontaminate patients suspected of being contaminated with mycotoxins.

e. Two decontamination team members move patient to the hotline and transfer him to a clean litter as described for chemical agent patients. Place the patient's FMC in the plastic bag on the clean litter with him. Two medics from the clean side of the hotline move the patient from the hotline to the clean treatment/holding area.

E-5. Decontaminate Biological Agent-Contaminated Ambulatory Patients

a. Remove the patient's FMC by cutting the tie wire and allowing it to drop into a plastic bag. Keep the bagged FMC with the patient.

b. Apply a liquid disinfectant solution, such as chlorine dioxide, over the patient's clothing.

c. Remove the patient's clothing as described for a chemical agent patient. Do not remove bandages, tourniquets, or splints. Place patient's clothing in a plastic bag and move the plastic bag to the contaminated waste dump.

d. Have the patient bathe with soap and warm water. If the patient is unable to bathe

himself, a member of the decontamination team must bathe him. Reapply the disinfectant solution. A medic places a new tourniquet 1/2 to 1 inch above the old one and removes the old one. A medic removes bandages and decontaminates the wound and surrounding skin area with the disinfectant solution or the 0.5 percent chlorine solution. The medic replaces the bandage if required to control bleeding. Splints are decontaminated in place by applying the disinfectant solution or the 0.5 percent chlorine solution to the splint, cravats, and straps.

NOTE

Use a 0.5 percent chlorine solution to decontaminate ambulatory patients suspected of being contaminated with mycotoxins.

e. Direct the patient to cross the hotline to the clean treatment area. His boots must be decontaminated at the hotline before he enters the clean treatment area.

NOTE

This patient becomes a litter patient. He must be placed in a patient protective wrap before evacuation.

E-6. Decontaminate Nuclear-Contaminated Patients

The practical decontamination of nuclear contaminated patients is easily accomplished without interfering with the required medical care.

NOTE

Patients must be monitored by using a RADIAC meter before, during, and after each step of the decontamination procedure.

E-7. Decontaminate a Nuclear-Contaminated Litter Patient

a. Patient decontamination team members remove the patient's outer clothing as described for chemical agent patients. Do not remove bandages, tourniquets, or splints. Move the patient to a clean litter. Place the patient's contaminated clothing in a plastic bag and move the bagged clothing to the contaminated waste dump.

b. Wash exposed skin surfaces with soap and warm water. Wash the hair with soap and warm water, or clip the hair and wash the scalp with soap and warm water.

c. Move the patient to the hotline. Two medics from the clean side of the hotline move the patient into the clean treatment area.

E-8. Decontaminate a Nuclear-Contaminated Ambulatory Patient

a. Have the patient remove or a decontamination team member assists the patient in removing his outer clothing. Place his contaminated clothing in a plastic bag and move the bagged clothing to the contaminated waste dump.

b. Wash exposed skin surfaces with soap and warm water. Wash his hair with soap and water, or clip the hair and wash the scalp with soap and water.

c. Direct the patient to move to the hotline. Decontaminate his boots before he crosses into the clean treatment area.

NOTE

This patient becomes a litter patient. He must be protected by using a blanket or other protective material during evacuation.

APPENDIX F

EVACUATION REQUEST PROCEDURES

F-1. General

Procedures for requesting medical evacuation support must be institutionalized down to the unit level. Procedural guidance and standardization of request procedures are provided in this appendix and FM 8-10-6.

F-2. Unit Evacuation Plan

Before initiating any operation, a unit must have an evacuation plan in effect. The plan may be a standard SOP or it may be designed for a particular operation. It can be published in various ways depending on the level of headquarters and the amount of detail required. For example, it may be in the form of verbal instructions at the squad or platoon level, a comment in the SOI, or a paragraph in the unit operations order. The unit evacuation plan is essential to requesting and effecting evacuation because it identifies—

- Primary and alternate channels to be used in submitting the MEDEVAC request (Table F-1).
- Primary and alternate evacuation route(s) to be used.
- Methods of evacuation to be used,
- Location of the destination medical treatment facilities to be used, if predesignated.

F-3. Determination to Request Medical Evacuation and Assignment of Medical Evacuation Procedures

The determination to request MEDEVAC and assignment of MEDEVAC precedence is made by the senior military person present, based on the advice of the senior medical person at the scene. Assignment of MEDEVAC precedence is necessary because it provides the supporting medical unit and controlling headquarters with information that is used in determining priorities for committing their evacuation assets. For this reason, correct assignment of precedence cannot be over-emphasized; overclassification remains a continuing problem. Patients will be picked up as soon as

possible, consistent with available resources and pending missions. The following are categories of precedence and the criteria used in their assignment:

- Priority I—URGENT. This precedence is assigned to emergency cases that should be evacuated as soon as possible and within a maximum of 2 hours to save life, limb, and eyesight.
- Priority IA—URGENT-SURG. This precedence is assigned to patients who must have far forward surgical intervention to save life and stabilize for further evacuation.
- Priority II—PRIORITY. This precedence is assigned to sick, injured, and wounded personnel requiring prompt medical care. This precedence is used when the individual should be evacuated within 4 hours or his medical condition will deteriorate to such a degree that he becomes an URGENT precedence.
- Priority III—ROUTINE. This precedence is assigned to personnel requiring evacuation, but whose medical condition is not expected to deteriorate significantly. The sick, injured, or wounded in this category should be evacuated within 24 hours.
- Priority IV—CONVENIENCE. This precedence is assigned to patients for whom air evacuation is a matter of medical convenience rather than necessity.

F-4. Unit Responsibilities in Evacuation

A decision to request MEDEVAC places certain responsibilities on the requesting unit in the overall evacuation effort. To prepare for and assist during evacuation, the unit must—

- a. Ensure that the tactical situation permits successful evacuation.
- b. Ensure that a person familiar with the principles of helicopter operations is designated to—
 - Select and prepare the landing site.

- Brief his ground crew on safety measures.
- Contact the pilot and provide directions to the landing site.
- Direct the loading and unloading of the helicopter according to the pilot's instructions.
- Brief the pilot on the position of enemy troops; direct him to other units in the area if asked; and make every effort to speed the helicopter on its way.

Receive back-hauled medical supplies and report the type and quantity, where they are delivered, and provide information concerning patients evacuated.

c. Ensure that patients are ready for pickup when the request is submitted.

d. Move patients to the safest aircraft approach and departure point.

e. Mark friendly positions when armed helicopter escort is provided.

f. Have an English-speaking representative at the pickup site when evacuation is requested for non-US personnel.

g. Guide the helicopter during landing and takeoff when the tactical situation permits.

F-5. Types of Medical Evacuation Request Formats and Procedures

a. There are two established MEDEVAC formats and procedures: one for wartime use and one used in peacetime. The wartime procedures are also used during peacetime training situations to request MEDEVAC for simulated and constructive patients.

(1) Simulated patients are those individuals who do not have a real wound, injury, or illness but must be physically moved or cared for to meet training and evaluation requirements.

(2) Constructive patients are representation of patients in reports, messages, or other

written and oral communications; they do not require physical movement or care.

b. Several differences exist between wartime and peacetime MEDEVAC request formats and procedures. The wartime MEDEVAC request format is shown at Table F-1. The peacetime request form differs in two line item areas:

(1) Line 6—changed to number and type of wound, injury, or illness (two gunshot wounds and one compound fracture). If serious bleeding is reported, it should be followed by the victim's blood type.

(2) Line 9—changed to description of terrain (flat, open, sloping, wooded). If possible, include relationship of landing area to prominent terrain feature.

c. Security is another basic difference between wartime and peacetime requesting procedures. Under all nonwar conditions, the safety of US military and civilian personnel outweighs the need for security and clear text transmissions of MEDEVAC requests are authorized. During wartime, the rapid evacuation of patients must be weighed against the importance of unit survivability. Accordingly, wartime MEDEVAC requests are transmitted by secure means only.

F-6. Collection of Medical Evacuation Information

The information collected for the wartime MEDEVAC request, Line numbers 3 through 9, is subject to brevity codes. The information collected is limited to the specific remarks provided in Table F-1. (Example: the information to be collected for Line 4 pertains to special equipment to be placed on board the evacuation vehicle. The limiting remarks restrict identification to: none required hoist; Stokes litter; and forest penetrator. No other remarks are authorized for Line 4.)

F-7. Preparation of the Medical Evacuation Request

Table F-1 provides the procedures for preparation of the MEDEVAC request, to include information requirements and sources:

a. During wartime and training situations, brevity codes must be used in preparing all MEDEVAC requests. The authorized codes are provided in Table F-1; they are also provided in the standard SO I, I tern 104. Use of locally devised brevity codes is not authorized. If the unit preparing the request does not have access to secure communications, the MEDEVAC request must be prepared in encrypted form. Encrypting is required for all information on the request with the exception of—

(1) The MEDEVAC line number identifier. This information is always transmitted in clear text.

(2) The call sign and suffix (Line 2) which can be transmitted in clear text.

b. During peacetime, two MEDEVAC line number items (Lines 6 and 9) will change. Details for the collection of information and request preparation are shown in Table F-1. More detailed procedures for use in the peacetime request format must be developed by each command to meet specific requirements.

Table F-1. Procedures for Information Collection and MEDEVAC Request Preparation. (1 of 3)

LINE	ITEM	EXPLANATION	WHERE/HOW OBTAINED	WHO NORMALLY PROVIDES	REASON
1	Location of Pickup Site.	Encrypt the grid coordinates of the pickup site. When using the DRYAD Numeral Cipher, the same "SET" line will be used to encrypt the grid zone letters and the coordinates. To preclude misunderstanding, a statement is made that grid zone letters are included in the message (unless unit SOP specifies its use at all times).	From Map	Unit Leader(s)	Required so evacuation vehicle knows where to pickup patient. Also, so that the unit coordinating the evacuation mission can plan the route for the evacuation vehicle (if the evacuation vehicle must pick up from more than one location).
2	Radio Frequency, Call Sign, and Suffix	Encrypt the frequency of the radio at the pickup site, not a relay frequency. The call sign (and suffix if used) of person to be contacted at the pickup site may be transmitted in the clear.	From SOI	RTO	Required so that evacuation vehicle can contact requesting unit while en route (obtain additional information or change in situation or directions).
3	Number of Patients by Precedence	Report only applicable information and encrypt the brevity codes. A - URGENT. B - URGENT SURGICAL. C - PRIORITY. D - ROUTINE. E - CONVENIENCE. If two or more categories must be reported in the same request, insert the word "BREAK" between each category.	From Evaluation of Patient(s)	Medic or Senior Person Present	Required by unit controlling the evacuation vehicles to assist in prioritizing missions.

Table F-1. Procedures for Information Collection and MEDEVAC Request Preparation. (2 of 3)

LINE	ITEM	EXPLANATION	WHERE/HOW OBTAINED	WHO NORMALLY PROVIDES	REASON
4	Special Equipment Required	Encrypt the applicable brevity codes. A - None. B - Hoist. C - Extraction equipment. D - Ventilator.	From Evaluation of Patient/Situation	Medic or Senior Person Present	Required so that the equipment can be placed on board the evacuation vehicle prior to the start of the mission.
5	Number of Patients by Type	Report only applicable information and encrypt the brevity code. If requesting MEDEVAC for both types, insert the word "BREAK" between the litter entry and ambulatory entry L + # of Pnt - Litter A + # of Pnt - Ambulatory (sitting)	From Evaluation of Patient(s)	Medic or Senior Person Present	Required so that the appropriate number of evacuation vehicles may be dispatched to the pickup site. They should be configured to carry the patients requiring evacuation.
6	Security of Pickup Site (Wartime)	N - No enemy troops in area. P - Possibly enemy troops in area (approach with caution). E - Enemy troops in area (approach with caution). X - Enemy troops in area (armed escort required).	From Evaluation of Situation	Unit Leader	Required to assist the evacuation crew in assessing the situation and determining if assistance is required. More definitive guidance can be furnished the evacuation vehicle while it is en route (specific location of enemy to assist an aircraft in planning its approach).
6	Number and Type of Wound, Injury, or Illness (Peacetime)	Specific information regarding patient wounds by type (gunshot or shrapnel). Report serious bleeding, along with patient blood type, if known.	From Evaluation of Patient	Medic or Senior Person Present	Required to assist evacuation personnel in determining treatment and special equipment needed.
7	Method of Marking Pickup Site	Encrypt the brevity codes. A - Panels. B - Pyrotechnic signal. C - Smoke signal. D - None. E - Other.	Based on Situation and Availability of Materials	Medic or Senior Person Present	Required to assist the evacuation crew in identifying the specific location of the pick up. Note that the color of the panels or smoke should not be transmitted until the evacuation vehicle contacts the unit (just prior to its arrival). For security, the crew should identify the color and the unit verify it.

Table F-1. Procedures for Information Collection and MEDEVAC Request Preparation. (3 of 3).

LINE ITEM	EXPLANATION	WHERE/HOW OBTAINED	WHO NORMALLY PROVIDES	REASON
8	Patient Nationality and Status The number of patients in each category need not be transmitted. Encrypt only the applicable brevity codes. A - US military. B - US civilian. C - Non-US military. D - Non-US civilian. E - EPW.	From Evaluation of Patient	Medic or Senior Person Present	Required to assist in planning for destination facilities and need for guards. Unit requesting support should ensure that there is an English-speaking representative at the pickup site.
9	NBC Contamination (Wartime) Include this line only when applicable. Encrypt the applicable brevity codes. N - Nuclear. B - Biological. C - Chemical.	From Situation	Medic or Senior Person Present	Required to assist in planning for the mission. (Determine which evacuation vehicle will accomplish the mission and when it will be accomplished.)
9	Terrain Description (Peacetime) Include details of terrain features in and around proposed landing site. If possible, describe relationship of site to prominent terrain feature (lake, mountain, tower).	From Area Survey	Personnel at Site	Required to allow evacuation personnel to assess route/avenue of approach into area. Of particular importance if hoist operation is required.

F-8. Transmission of the Request

The MEDEVAC request should be made by the most direct communications means to the medical unit that controls evacuation assets. The communications means and channels used depend on the situation (organization, communication means available, location on the battlefield, distance between units). The primary and alternate channels to be used for requesting MEDEVAC are specified in the unit evacuation plan.

a. Secure Transmissions. Under all wartime conditions and for constructive and simulated patients during training, MEDEVAC requests will be transmitted by SECURE MEANS only. Therefore, the use of nonsecure communications dictates that the MEDEVAC request be transmitted in ENCRYPTED FORM. Regardless of the type (secure or nonsecure) communications equipment used in transmission, it is necessary to—

- Make contact with the intended receiver.
- Use the call sign and frequency assignments from the SOL
- Use the proper radio procedures.
- Ensure that transmission time is kept to a minimum (20 to 25 seconds maximum).
- Provide the opening statement: “I HAVE A MEDEVAC REQUEST.”

b. Receiver Acknowledgement. After the appropriate opening statement is made, the transmitting operator breaks for acknowledgement. Authentication by the receiving or transmitting unit should be done in accordance with SOP.

c. Clear Text and Encrypted Transmissions.

If secure communications equipment is used in transmission, the MEDEVAC request will be transmitted in CLEAR TEXT. However, if the communications equipment used in transmission is not secure, the MEDEVAC request must be transmitted in ENCRYPTED FORM with the exception of the following:

(1) The MEDEVAC line number identifier (Line 1, Line 2, Line 3, and so forth). This information is always transmitted in clear text.

(2) The call sign and suffix (Line 2) which can be transmitted in clear text.

NOTE

When using DRYAD Numeral Cipher, the same "SET" line is used to encrypt the grid zone letters and the coordinates (Line 1 of the MEDEVAC request). To avoid misunderstanding, a statement is made that the grid zone letters are included in the message. This must be accomplished unless the unit SOP specifies that the DRYAD Numeral Cipher is to be used at all times.

d. Letter and Numeral Pronunciation. The letters and numerals that make up the request will be pronounced in accordance with radio procedures. In transmission of the request, the MEDEVAC line number identifier will be given followed by the evacuation information (example: Line One. TANGO PAPA FOUR SIX FIVE THREE SEVEN NINER).

e. MEDEVAC Line Numbers 1 through 5. MEDEVAC Line numbers 1 through 5 of the request must always be transmitted first. The information enables the evacuation unit to begin the mission and avoids unnecessary delay if the remaining information is not immediately available. The information for Lines 6 through 9 may be transmitted to the evacuation vehicle en route.

f. Monitoring Requirement. After transmission and acknowledgement are accomplished, the transmitting operator must monitor the frequency (Line 2 of the request) to wait for additional instructions or contact from the evacuation vehicle.

F-9. Relaying Requests

If the unit receiving the request does not control the evacuation means, it must relay the request to the headquarters or unit that has control or to another relaying unit. When the relaying unit does not have access to secure communications equipment, the request must be transmitted in encrypted form. The method of transmission and specific units involved depends on the situation. Regardless of the method of transmission, the unit relaying the request must ensure that it relays the exact information originally received and that it is transmitted by secure means only. The radio call sign and frequency relayed (Line 2 of the request) should be that of the requesting unit and not that of the relaying unit. If possible, intermediate headquarters or units relaying requests will monitor the frequency specified in Line 2. This is necessary in the event contact is not established by the MEDEVAC unit or vehicle with the requesting unit.

F-10. Helicopter Landing Sites

a. Responsibility. The unit requesting air ambulance service is responsible for selecting and properly marking the helicopter landing sites.

b. Criteria for Landing Sites.

(1) The helicopter landing site and its approach zones to the areas should be free of obstructions. Sufficient space must be provided for the hovering and maneuvering of the helicopter during landing and takeoff. The approach zones should permit the helicopter to land and take off into the prevailing wind whenever possible. It is desirable that landing sites afford helicopter pilots the opportunity to make shallow approaches.

(2) Definite measurements for landing sites cannot be prescribed since they vary with temperatures, altitude, terrain, loading conditions,

and individual helicopter characteristics. The minimum requirement for light helicopters is a cleared area of 30 meters in diameter with an approach and departure zone clear of obstructions. The CH-47 Chinook should not be brought into a landing site that is smaller than 40 meters in diameter.

c. Removing or Marking Obstructions. Any object likely to be blown about by the wind from the rotor should be removed from the landing area. Obstacles, such as cables, wires, or antennas at or near the landing sites, which cannot be removed and may not be readily seen by a pilot, must be clearly marked. Red lights are normally used at night to mark all obstacles that cannot be easily eliminated within a landing site. In most combat situations, it is impractical for security reasons to mark the tops of obstacles at the approach and departure ends of a landing zone. In a training situation or at a rear area landing site, red lights should be used whenever possible to mark obstructions. If obstacles or other hazards cannot be marked, pilots should be advised of existing conditions by radio.

d. Identifying the Landing Site (Figures F-1 through F-4).

(1) When the tactical situation permits, a landing site should be marked with the letter "H," "T," or "Y," using identification panels or other appropriate marking material. Special care must be taken to secure panels to the ground to prevent them from being blown about by the rotor wash. Firmly driven stakes will secure the panels tautly; rocks piled on the corners are not adequate.

(2) If the tactical situation permits, the wind direction may be indicated by a small wind sock or rag tied to the end of a stick in the vicinity of the landing site, by a man standing at the upwind edge of the site with his back to the wind and his arms extended forward, or by smoke grenades which emit colored smoke as soon as the helicopter is sighted.

(3) In night operations, the following factors should be considered:

(a) One of the many ways to mark a landing site is to place a light at each of the four corners of the usable landing area. These lights

should be colored in order to distinguish them from other lights which may appear in the vicinity. A particular color can also serve as one element in identifying the site. Flare pots or other types of open lights should not be used because they usually are blown out by the rotor downwash and often create a hazardous glare and/or reflection on aircraft windshields. The site can be further identified and distinguished from others operating in the general vicinity by a coded signal flash to the pilot from a ground operator using the directed beam of a signal lamp, flashlight, vehicle lights, or other means previously agreed upon. The coded signal is continuously flashed to the pilot until recognition is assured. After recognition, the signal operator, from his position on the upwind side of the landing site directs the beam of light downward along the ground to bisect the landing area. The pilot makes his approach for landing in line with the beam of light and towards its source, landing at the center of the marked area. All lights are displayed for only a minimum time before arrival of the helicopter and are turned off immediately after the aircraft lands.

(b) When the use of standard lighting methods is not possible, pocket-sized red and/or white strobe lights or chemical light sticks are excellent means for aiding the pilot in identifying the land zone. Open flames should be used only as a last resort. When using open flames, ground personnel should advise the pilot before he lands. Burning material must be secured in such a way that it will not blow over and start a fire in the landing zone. Precautions should be taken to ensure that open flames are not placed in a position where the pilot must hover over or be within three meters of them.

(c) During takeoff, only those lights requested by the pilot are displayed; they are turned off immediately after the aircraft's departure.

(4) When the helicopter approaches the landing site, the ground contact team can ask the pilot to turn on his rotating beacon briefly in order to identify the aircraft and confirm its position in relation to the landing zone. The rotating beacon can be turned off as soon as the ground contact team has located and identified the aircraft. The ground contact team can help the pilot by informing him of

his location in relation to the landing zone, observing the aircraft's silhouette, and guiding the aircraft toward the landing zone. While the aircraft is maneuvering toward the landing zone, two-way radio contact is maintained and the type of lighting or signal being displayed is described by the pilot and verified by the ground personnel via radio. The signal should be continued until the aircraft touches down in the landing zone.

(5) Proper use of FM homing procedures can prove to be a valuable asset. Through the use of FM homing, the pilot can more accurately locate personnel on the ground. The success of a homing operation depends upon the actions of personnel on the ground. First, they must be operating an FM radio which is capable of transmitting within the frequency range of 30 to 69.95 megahertz; then they must be able to gain maximum performance from the radio through proper tuning and operation as prescribed in the technical manual for the set. The range of FM radio communications is limited to line of sight; therefore, personnel should remain as clear as possible of obstructions and obstacles which could interfere with or totally block the radio signals. Ground personnel must have knowledge of the FM homing procedures. When the pilot asks the radio operator to "key the microphone," he is simply asking that the transmit button be depressed for a period of 10

to 15 seconds. This gives the pilot an opportunity to determine the direction to the person using the radio.

F-11. Loading Patients Aboard Rotary-Wing Aircraft.

a. Responsibility for Loading and Securing.

The pilot of the evacuation aircraft is responsible for ensuring that the litter squad follows the prescribed methods of loading and securing litters and related equipment. The final decision regarding how many patients may be safely loaded into the helicopter rests with the pilot.

b. Safety Measures. When loading and unloading a rotary-wing aircraft, certain precautionary measures must be observed. Litter bearers must present as low a silhouette as possible and must keep clear of the rotors at all times. The helicopter must not be approached until signaled to do so and then approached at a 45 degree angle from the front of the aircraft. If the helicopter is on a slope and conditions permit, loading personnel should approach the aircraft from the downhill side. Directions given by the crew must be followed, and litters must be carried parallel to the ground. Smoking is not permitted within 50 feet of the aircraft.

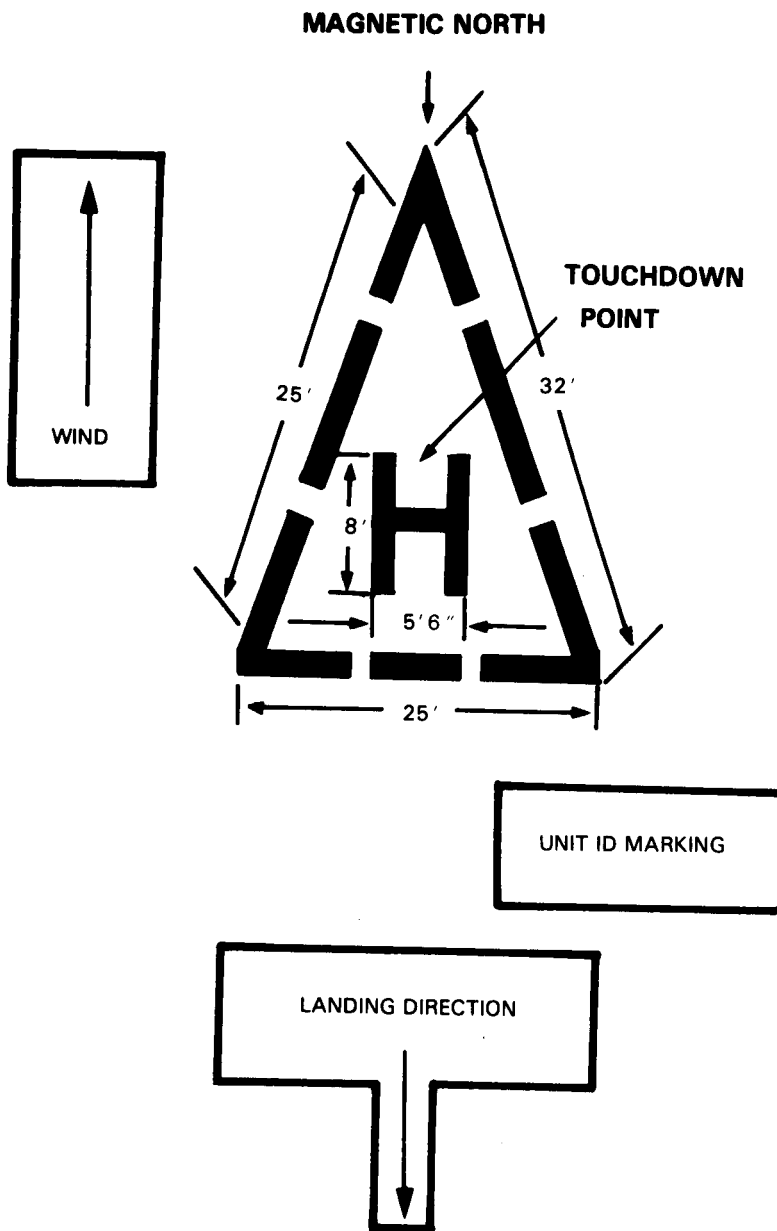

Figure F-1. Semifix base operations (daylight).

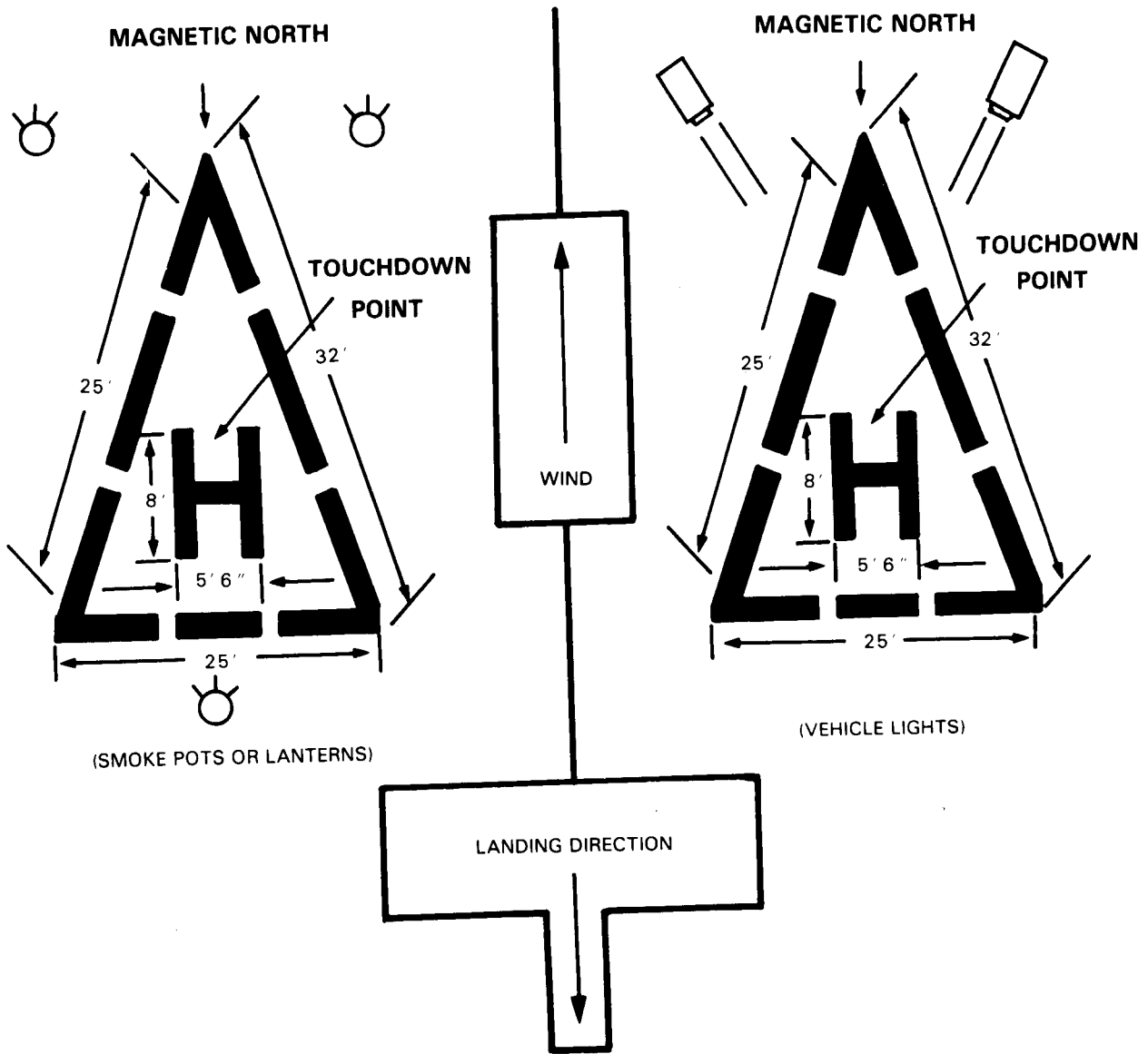

Figure F-2. Semifix base operations (night).

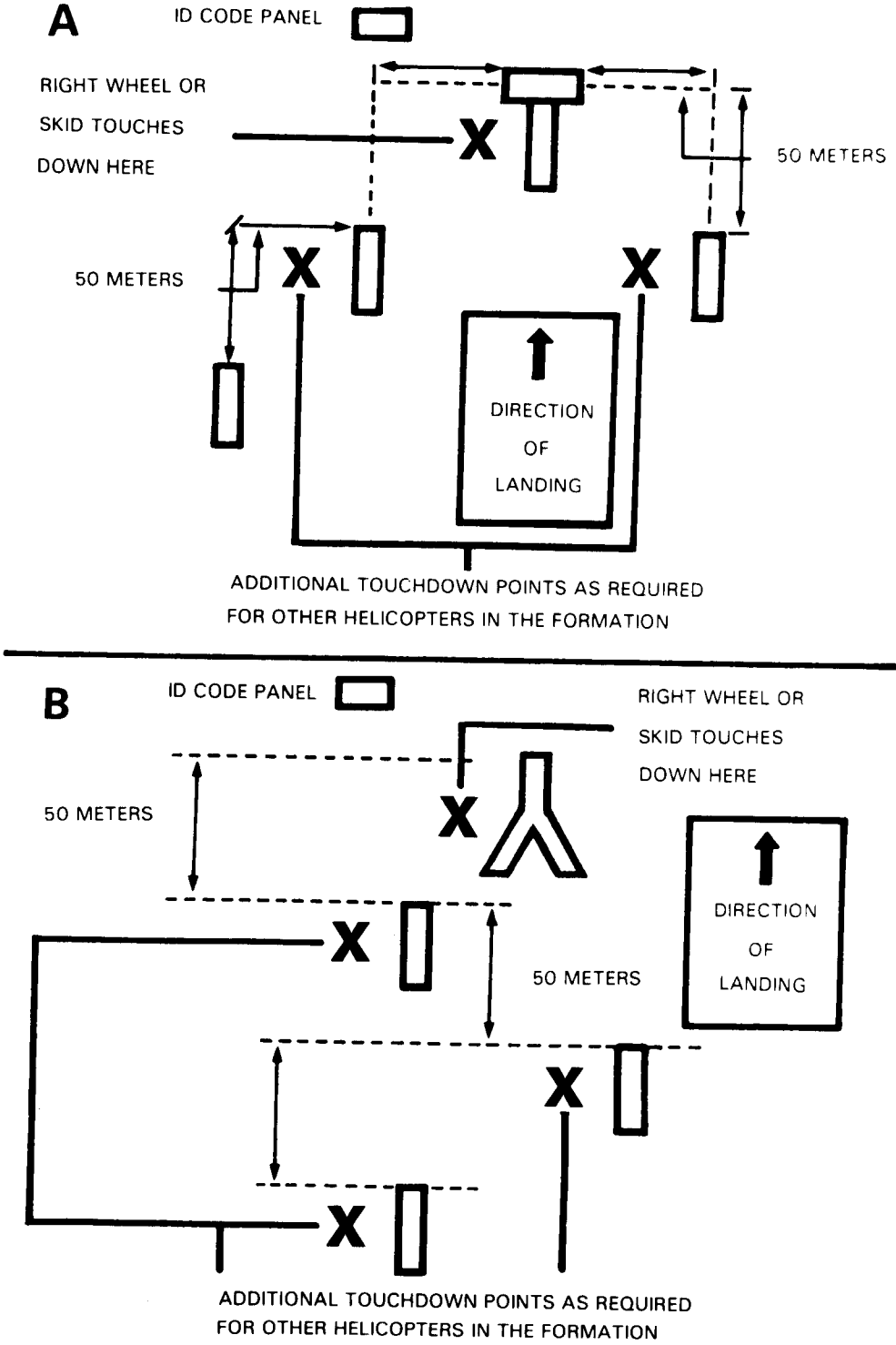

Figure F-3. Field expedient landing zone (day).

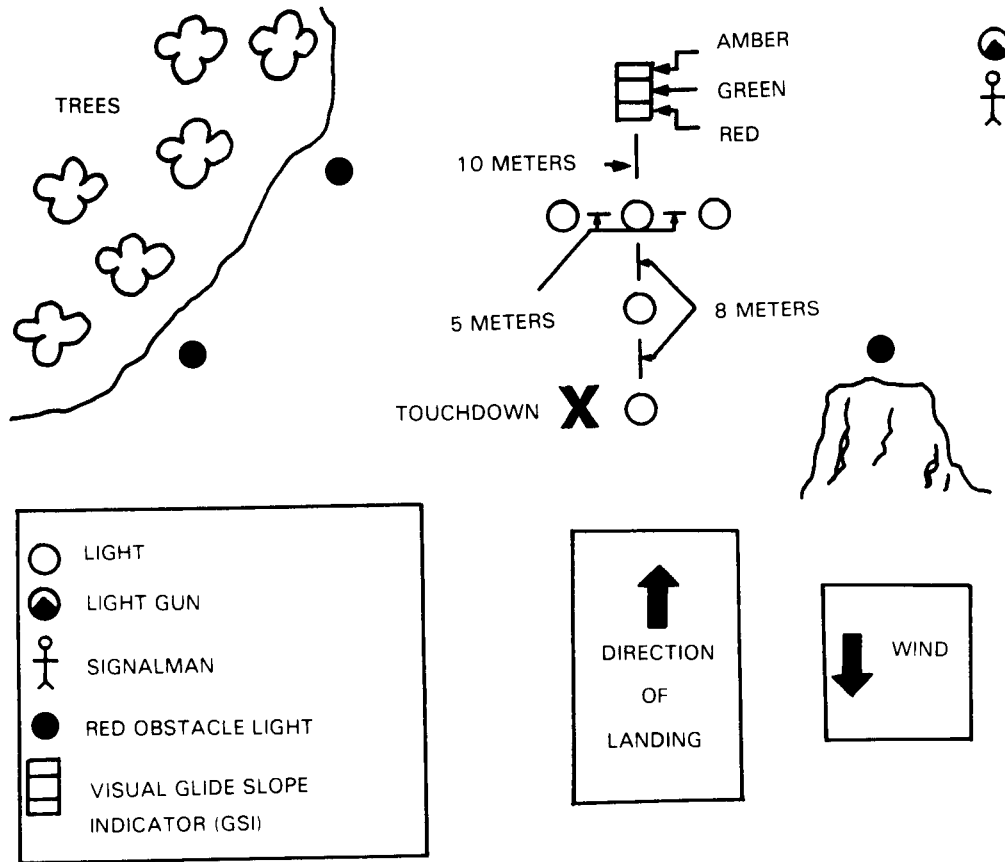

Figure F-4. Field expedient landing zone (night).

APPENDIX G

COMBAT TRAINING CENTERS LESSONS LEARNED**G-1. Planning for Deployment to Combat Training Centers**

Planning for deployment to Combat Training Centers (CTCs) must begin months in advance of the actual departure date. Plans must include the following at a minimum:

- Arrange for PROFIS physician to accompany medical platoon to CTC. Coordinate through division surgeon at least 120 days prior to rotation.
- Determine transportation requirements: such as how many and what type railcars will be required for movement by rail (flat or box)? To determine the number of cars required, the weight and cube of all components (to include personal gear, CTA items, and leased items) must be established. Begin making transportation arrangements at least 6 months in advance of departure date; also coordinated the arrangements with your S4. The exclusion of any TOE items due to transportation constraints must be carefully evaluated for the impact on the mission.
- Arrange for the lease of essential equipment not provided for in the TOE. EXAMPLE: cardiac defibrillator/monitor, for use in real world medical treatment of patients. Arrange for the lease at least 6 months before the departure date to ensure that the item is on hand.
- Ensure that all medical equipment sets are complete. Request medical items (controlled/accountable drugs) at least 2 months before rotation.
- Ensure that all TOE equipment is on hand and in working order. Verify the status and availability of all equipment at least 2 months before rotation. Have all equipment serviced/ repaired as needed to be 100 percent operational.
- Arrange for POL support.
- Establish resupply support (including Class VIII) for items needed during the training period. Prepare signature cards for request and receipt of supplies. Arrange for support from HSS elements/hospital for patients requiring care beyond your unit capabilities.

- Prepare for prevention of heat injury casualties. EXAMPLE: Ensure water consumption policies are established and monitored. Personnel must drink water frequently.

- Establish food service support if not provided for in deployment instruction.

- Ensure sundry supplies are available for personnel.

- Prepare overlays showing BAS, AXP, PCP, and split treatment team locations, if maps of the operational area are available.

- Prepare OPORD, SOP, and HSSPLAN for medical platoon. Prepare input for inclusion in higher command and support elements' OPORD, SOP, and HSSPLAN.

- Prepare unit for mission through unit training at home station; begin training METL upon notification of rotation if not already in force.

G-2. Medical Lessons Learned

Lessons learned from medical units during CTC rotations are as follows:

- Medical platoon leadership not preparing/reviewing and forwarding feeder reports in a timely manner.

- Exclusion of physicians from CTC rotation is hindering the medical platoon in conducting realistic training.

- The crew on the M113 is inadequate to provide en route patient care. Two medics authorized (driver and treater); three required (driver, track commander, treater). Armor requires a track commander.

- Combat medic with radio required to man the AXP.

- Field artillery medical section does not have radios.

- BAS authorized systemic, pulmonary, and anaphylaxis resuscitative kit (SPARK), but no cardiac defibrillator/monitor.

- Work/rest not practiced by line units. Personnel working 30 plus hours without rest periods. Performance degraded after this length of time.
- Use of lensatic compass requires dismounting tracked vehicles. For accurate readings, the TC must be several meters from the vehicle.
- Early request for nonmedical vehicle Support in movement of mass casualties was not supported on a timely basis.
- Communications was hindered by radios being borrowed from medical units and not available for the BAS to contact the medical company.
- BAS M577s being used as alternate combat trains CPs. This violates the Geneva Conventions, jeopardizing the patients and medical units protection.
- BAS not employing the M51 shelter system during training. This prevented their training in the employment of the system.
- Resupply system for medical supplies inadequately planned for and ineffective.
- Cooled storage for IV solution not provided at the BAS. These solutions require protection from excessive heat such as desert/hot climate conditions (NTC environment).
- Medical platoon deploying without night vision devices although authorized by MTOE.
- Mass casualty plans need to be well developed, coordinated with supporting units/sections, documented in an SOP, and rehearsed during training.
- The medical platoon leader is a member of the staff and should be accepted as such. He should attend mission briefings and have the responsibility for medical planning and, in turn, brief the medical support plan. When the medical platoon leader is not included in the planning, this can result in missed coordination when the taskings are finally passed to the medical platoon.
- During the planning phase, the battalion needs to—
 - Develop a plan to access, handle, evacuate, and treat NBC casualties.
 - Look at methods for performing MEDEVAC missions.
 - Ensure the assets required for mission accomplishment are included.
 - Provide a plan for including the medics on the mission.
- The support for medical evacuation requires an analysis by the medical support element. They must determine the best methods to support the tactical operations based on the platoon's status and capabilities.
- Companies submitted an abbreviated MEDEVAC request which severely degraded casualty evacuation. Lines often omitted included site frequency, call sign, and security. This resulted in patients not being located and evacuation vehicles being destroyed. Units must become familiar with the MEDEVAC request format. It must be used during all field training exercises.
- An effective SOP for casualty evacuation; soldiers understanding of first aid procedures; and leaders awareness of the combat and field trains locations are instrumental in preventing soldiers dying of wounds.
- Coordination of medical evacuation operations must be emphasized within the battalion. The battalion needs to standardize procedures for designating patient collecting points and the hand over of patients to the medical company.
- Units need to triage/prioritize casualties for treatment and evacuation. When this is not done, soldiers with superficial wounds are treated before those with life-threatening wounds. A unit SOP for casualty evacuation can consolidate or coordinate the effort. The absence of sufficient medics and trained combat lifesavers can intensify the problem.

- When casualties were taken on the battlefield, self-aid or buddy aid was rarely administered. When aid and litter teams were identified, soldiers were uncertain of their duties/responsibilities as aid/litter team members. There was no plan or system in place to ensure casualties were treated and evacuated to the patient collecting points. Once at the patient collecting point, there was no triage during evacuation. If the company had two patient collecting points, casualties were evacuated to the other collecting point without regard to the type and extent of injury. On several occasions, the unit did not know that their casualties were never evacuated from the company patient collecting point. This resulted in soldiers dying of wounds.

- The medics in the line companies did not establish and maintain platoon and company patient collecting points effectively. The medics did not consistently organize collecting points to facilitate rapid evacuation of patients. Sites for LZ/PZs for MEDEVAC operations were not selected consistently or effectively. The lack of triage and treatment of patients resulted in several patients being designated as died of wounds. Though the technical proficiency was present, the ability to apply those skills to a tactical environment was not always evident.

- The battalion S1 and the medical platoon leader must develop a medical evacuation plan based on METT-T. The medical platoon leader supervises the execution of his portion of the plan in the forward area.

- The need to brief CSS personnel and rehearse their functions is just as critical as the rehearsals conducted by maneuver units. Route and convoy briefings, patient evacuation practice, and security reaction plans must all be briefed and practiced. Ensure rehearsals are conducted to the lowest possible level and for all probable contingencies in preparation for all operations.

- Classes (OPD/NCOPD) need to be caught which explain in detail the HSS system of a light infantry division. The battalion PA or personnel from the medical battalion should be considered as instructors. All FTXs need to incorporate HSS play in the scenarios, from squad through brigade level.

- The medical platoon leader needs to receive training from the medical battalion to include participation in their FTXs/CPXs. The battalion should give him time to learn his job and not overwhelm him with additional duties.

- The battalion medical platoon, in conjunction with the medical company, should war-game medical evacuation procedures to clearly define responsibilities and refine support requirements. This war-gaming can be conducted using the LOGMOD/ADMIN GTAs, various terrain models, and various missions which the battalion can receive.

- Practice preparation of formalized staff estimates and the service support paragraph or annex of orders. The formats and procedures must be practiced to ensure complete written or verbal orders are prepared for actual field operations. The most important requirement is to understand the format; to prevent the omission of critical information when orders are prepared in the stressful environment of a field operation.

- Practice using air ambulances to include support planning, LZ site selection and preparation, defense, and communications.

- War-game the coordination procedures used by the regiment to execute the HSS missions at all levels. These war games (executed using the MED SIM GTA and the LOGMOD GTA) are available from all local TASCs. They will assist in refining procedure and in structuring the HSS system at all levels.

- There needs to be cross-training to cover those MOSs that are one deep in the unit. Reassignments or injuries may keep these personnel from deploying. They may become incapacitated while in the field. Their absence will cause a decline in the quality of care being provided.

- Medical evacuation should have a dedicated radio frequency; it should be monitored by the medical company. If the SOI does not list a frequency, then employ a spare.

- The battalion aid station must establish and maintain communication with the supporting medical company at all times. When contact is

broken, the platoon leader must hastily rectify the situation. Presently, calls go through the field trains, brigade tactical operations center, and FASCO before being received by the supporting medical company. This caused a waste of time, delay in response, and ties up communication nets.

- Combat lifesavers are an integral facet of the HSS doctrine. They place life-sustaining skills

within each crew/team/section. With a minimal number of medical personnel assigned in the line units, the combat lifesavers and their equipment, add the required dimension of care that can decrease the number of died of wounds. In the mass casualty situations that occurred during this rotation, their valued training was not present.

APPENDIX H

THE GENEVA CONVENTIONS

H-1. Effect of Geneva Conventions on Health Service Support

The conduct of armed hostilities on land is regulated by both written and unwritten law. This land warfare law is derived from two principal sources—custom and lawmaking treaties such as the Hague and Geneva Conventions. The rights and duties set forth in these conventions are part of the supreme law of the land; a violation of any one of them is a serious offense.

H-2. Geneva-Wounded and Sick (GWS)

a. Custodial and medical responsibilities must be carried out for persons (military or civilian) who are wounded as a result of military operations regardless of their nationality or legal status.

NOTE

Persons whose legal status is in doubt are accorded protection and treatment as prisoners of war until their legal status is determined.

b. Collection and treatment of the sick and wounded are responsibilities of medical personnel. The custodial and accounting functions are responsibilities of military police.

H-3. Identification and Protection of Medical Personnel Under GWS

Medical personnel who become captured are not considered prisoners of war but retained personnel.

a. Protected personnel include—

(1) AMEDD personnel exclusively engaged in the—

- Search for or collection, transport, or treatment of the wounded or sick.
- Prevention of disease.
- Administration of medical units and establishments (for example, this includes

personnel such as the office staff, ambulance drivers, cooks, cleaners which form an integral part of the unit or establishment).

- Veterinary staff functions relating to the administration of medical units and establishments.

(2) Non-AMEDD personnel who have received special medical training, if carrying out their auxiliary medical duties when captured by the enemy. Once in enemy hands they become prisoners of war when not doing medical work.

(3) Chaplains.

b. Each protected individual must—

(1) Carry a special water-resistant, pocket-size identity card (DD Form 1934) which—

- Bears the red cross on a white background (the distinctive emblem of the Geneva Conventions).

- Is worded in the national language of the issuing force.

- Contains the surname and first name (at least), date of birth, rank, social security number, protected capacity serving, photograph, signature, and/or fingerprints of carrier.

- Is embossed with the stamp of the appropriate military authority (AR 640-3).

(2) Wear on the left arm a water-resistant armband bearing the red cross emblem of the Geneva Convention (DA Pam 27-1 and FM 27-10).

H-4. Identification of Medical Units, Facilities, and Vehicles Under GWS

a. Identify—

(1) All medical units and facilities except veterinary units. Medical facilities also include the nonpatient care areas, such as those for dining, maintenance, and administration.

(2) Air and surface (ground and water) medical vehicles.

Paragraph H-5 implements STANAG 2931.

NOTE

Under tactical conditions, the need for concealment may outweigh the needs for recognition (AR 750-1).

b. How:

(1) Display the distinctive flag of the Geneva Conventions (red cross on a white background) over the unit/facility and in other places on the unit/facility as necessary to adequately identify it. (The other emblem recognized by terms of Geneva Convention is the red crescent. Emblems not recognized by the Geneva Convention but used by other countries, such as the red shield of David by Israel, should also be respected.)

(2) Mark with the distinctive Geneva emblem (red cross on a white background).

(3) The GWS protects from attack any medical vehicle appropriately marked and exclusively employed for the evacuation of the sick and wounded or for the transport of medical personnel and equipment. The GWS prohibits the use of medical vehicles marked with the distinctive emblems for transporting nonmedical troops and equipment.

H-5. Camouflage of the Geneva Emblem

NATO Standardization Agreement 2931 OP provides for camouflage of the Geneva emblem on medical facilities where the lack of camouflage might compromise tactical operations. Medical facilities on land, supporting forces of other nations, will display or camouflage the Geneva emblem in accordance with national regulations and procedures. When failure to camouflage would endanger or compromise tactical operations, the camouflage of medical facilities may be ordered by a NATO commander of at least brigade level or equivalent. Such an order is to be temporary and local in nature and countermanded as soon as the circumstances permit. It is not envisaged that fixed, large, medical facilities would be camouflaged. The Standardization Agreement defines "medical facilities" as "medical units, medical vehicles, and medical aircraft on the ground."

H-6. Defense of Self and Patients Under Care**a. Protected personnel are-**

(1) Authorized to be armed with only individual small arms. (AR 71-13 provides the doctrine that governs the small arms medical personnel are authorized [limited to pistols or rifles, or authorized substitutes].) These small arms may only be used for defensive purposes. The presence of machine guns, grenade launchers, booby traps, hand grenades, light antitank weapons, or mines in or around a medical unit would seriously jeopardize its entitlement to protected status under the GWS. The deliberate arming of a medical unit with such items could constitute an act harmful to the enemy and cause the medical unit to lose its protected status under the Convention. This conclusion is not altered in the case of mines regardless of the method by which they are detonated nor is it altered by the location of the medical unit. If the local non-AMEDD commander situates a medical unit where enemy attacks may imperil its safety, then that commander should provide adequate protection for the medical unit and its personnel.

(2) Permitted to fire only when they or their patients are under direct attack in violation of the GWS. Use of arms by AMEDD personnel for other than protection of themselves or their patients violates the GWS provisions governing the protected status of AMEDD personnel and results in the loss of protected status. AR 350-41 states the AMEDD personnel and non-AMEDD personnel in medical units will not be required to train or qualify with weapons other than individual or small arms weapons. However, AMEDD personnel attending training at NCO education system courses will receive weapons instruction that is part of the curriculum. This will ensure that successful completion of the course is not jeopardized by failure to attend the weapons training portion of the curriculum.

(3) Responsible for their own defense when operating at locations which preclude their being incorporated within defensive perimeters of nonmedical units. In addition to relying on their special status, medical units can provide for their defense by employing passive defense measures. Passive measures are those taken to reduce the

probability of and to minimize the effects of damage caused by hostile action. Examples of these measures are the preparation of individual fighting positions within the immediate unit area; noise and light discipline; posting perimeter sentries; and channeling traffic in the unit area.

b. Protected personnel (under overall security defense plans) will NOT be required—

- To man or help man the perimeter defense of nonmedical units such as unit trains, logistical areas, or base clusters.
- To take offensive action against enemy troops.

To require such actions will cause loss of protected status and will result in inadequate care of our sick and wounded prisoners of war. The platoon leader must clearly articulate this to all levels of command. The misuse of HSS vehicles/equipment will void all protection granted under the Geneva Conventions.

H-7. Geneva-Prisoners of War

a. US Military Forces are responsible for EPWs from the moment of capture.

b. The echelon commander and medical unit commanders jointly exercise responsibilities for the custody and treatment of the sick, injured, or wounded enemy personnel and detained civilian personnel.

c. The sick, injured, or wounded prisoners are treated and evacuated through normal medical channels but are physically segregated from United States and allied patients. They are guarded by persons other than medical personnel as provided by

the echelon commander. Evacuation of these EPW patients from the combat zone is initiated as soon as their medical conditions permit.

d. When intelligence indicates that large number of EPWs may result from an operation, medical units may require reinforcement to support the anticipated additional EPW patient work load. Procedures for estimating the medical work load involved in the treatment and care of enemy EPW patients are described in FM 8-55.

e. Enemy medical personnel are considered retained personnel rather than prisoners of war. They are to be employed to the maximum extent possible in such health service support duties as caring for detained or EPW patients, preferably those of their own armed forces. Captured medical supplies should be used in the care of these patients.

H-8. Geneva-Civilian Persons

a. When the United States is the occupying power, US Forces have the responsibility to ensure that all civilian and refugee subsistence and health service needs are provided.

b. Sick or injured civilian persons resulting from military operations are provided initial medical treatment, as required, in conformance with established theater policies; then, they are transferred to appropriate civil control authorities as soon as possible. When such persons are evacuated, proper accommodations must be provided, including satisfactory conditions of hygiene, health, safety, and nutrition (Articles 49 and 55). In conditions of armed conflict and to the extent practicable, the Army must seek to fulfill the above commitments, as well as to protect and assist civilians and refugees under its control.

GLOSSARY

ABBREVIATIONS, ACRONYMS, AND DEFINITIONS

AC	area code	AS MART	Army Medical Department Systematic Modular Approach to Realistic Training
ACR	armored cavalry regiment		
AD	air defense	Asst	assistant
ADA	air defense artillery	ATGM	antitank guided missile
ADC	assistant division commander	ATLS	advanced trauma life support
ADC-M	assistant division commander—maneuver	ATM	advanced trauma management
ADC-OT	assistant division commander—operations and training	ATP	ammunition transfer point
ADC-S	assistant division commander—support	AVIM	aviation intermediate maintenance
admin	administration	AXP	ambulance exchange point
ADP	automatic data processing	BAS	battalion aid station
AFMIC	Armed Forces Medical Intelligence Center	BDAR	battle damage assessment and repair
AG	Adjutant General	Bde	brigade
AHSUSA	Academy of Health Sciences, US Army	BF/NP	battle fatigue/neuropsychiatric
ALO	aviation liaison officer	BFV	Bradley fighting vehicle
AM	amplitude modulation	BICC	battlefield information control center
amb	ambulance	Biomed	biomedical
AMCO	aircraft maintenance company	BMO	battalion maintenance officer
AMDF	Army Master Data File	Bn	battalion
AMEDD	Army Medical Department	BP	battle position
AO	area of operations	Br	branch
APRT	Army Physical Readiness Test	BSA	brigade support area
AR	Army Regulation	C²	command and control
ARTEP	Army Training Evaluation Plan	CAB	combat aviation brigade
ASL	authorized stockage list	CAM	chemical agent monitor
		CAP	company aid post

CAS	close air support	DA	Department of the Army
CBT	combat	DA Pam	Department of Army Pamphlet
Cdr	commander	DCS	division clearing station
CE	communications-electronic	DD	Defense Department
CESO	communications - electronics staff officer	DE	directed energy
CFA	covering force area	decon	decontamination
CFV	cavalry fighting vehicle	DIA	Defense Intelligence Agency
cGy	centigray	DISCOM	division support command
CLS	combat lifesaver	Div	division
co	commander/commanding officer	DIVARTY	division artillery
COMMO	communications	DMHS	division mental health service
COMMZ	communications zone	DMMC	division materiel management center
COMSEC	communications security	DMOC	division medical operations center
CONUS	continental United States	DMSO	division medical supply office
COSCOM	corps support command	DNBI	disease and nonbattle injuries
CP	command post	DOD	Department of Defense
CPS	collective protective shelter	DOW	died of wounds
CPX	command post exercise	Drv	driver
CS	combat support	DS	direct support
CSC	combat stress control	DSA	division support area
CSCC	combat stress control company	DZ	drop zone
CSM	command sergeant major	EAC	echelons above corps
CSS	combat service support	EDRE	emergency deployment readiness exercise
CTA	common table of allowances	EFMB	Expert Field Medical Badge
CTC	Combat Training Center	EMT	emergency medical technician/ emergency medical treatment
CZ	combat zone		

EPW	enemy prisoner of war	G3	Assistant Chief of Staff, G3 (Operations and Plans)
ETS	expiration term of service	G4	Assistant Chief of Staff, G4 (Logistics)
EVAC	evacuation	G5	Assistant Chief of Staff, G5 (Civil Affairs)
Evac Bn	evacuation battalion	GC	Geneva-Civilian Persons
EW	electronic warfare	Gen	generator
FA	field artillery	GP	group
FARP	forward area refuel point	GPW	Geneva-Prisoners of War
FARRP	forward area rearm and refuel point	GS	general support
FASCO	forward area support coordination officer	GTA	graphic training aid
FAST	forward area support team	GWS	Geneva-Wound and Sick
FEBA	forward edge of the battle	HATS	health alert and threat summary
Fld	field	HHB	headquarters and headquarters battery
FLOT	forward line of own troops	HHC	headquarters and headquarters company
FM	frequency modulation/field manual	HHS	headquarters and headquarters support company
FMC	Field Medical Card	HHT	headquarters and headquarters troop
FOUO/ NOFORN	for official use only/not releasable to foreign nationals	Hlth	health
FRAGO	fragmentation orders	HMMWV	high mobility multi-purpose wheeled vehicle
FSB	forward support battalion	HQ	headquarters
FSCoord	fire support coordinator	HREC	health record
FSE	fire support element	HSC	headquarters and support company
FSMC	forward support medical company	HSMO	health service materiel officer
FSO	fire support officer	HSS	health service support
FTX	field training exercise	HSSPLAN	health service support plan
G1	Assistant Chief of Staff, G1 (Personnel)		
G2	Assistant Chief of Staff, G2 (Intelligence)		

IAW	in accordance with	Maint	maintenance
IDSM	intermediate direct support maintenance	MBA	main battle area
IEW	intelligence and electronic warfare	MCO	movement control officer
IFV	infantry fighting vehicle	MCP	maintenance collection point
IHFR	improved high-frequency radio	Mech	mechanized/mechanic
Intel	intelligence	MED	medical
IPB	intelligence preparation of the battlefield	Med Bde	medical brigade
IPD	Institute for Professional Development	MEDCAP	medical civic action program
IPR	intelligence production requirement	MEDCOM	medical command
ITV	improved tow vehicle	MEDDAC	medical activity
IV	intravenous infusion	MEDEVAC	medical evacuation
LASER	light amplification by stimulated emission of radiation	Med Gp	medical group
LBE	load bearing equipment	MEDLOG	medical logistics
Ldr	leader	MEDOPS	medical operations
LIC	low intensity conflict	MEDSOM	medical supply, optical, and medical maintenance
LO	liaison officer/lubrication order	MEDSTEP	medical standby equipment program
LOG	logistics	MES	medical equipment set
LOGMOD	logistics module	METL	mission essential task list
LOGPLAN	logistics plan	METT-T	mission, enemy, terrain, troops, and time available
LRA	local reproduction authorized	MI	military intelligence
LRS	long-range surveillance	MIP	mission oriented intelligence production
LtWVeh	light wheeled vehicle	MOC	medical operations center
LZ	landing zone	MOD	module
MACOM	major command	MOPP	mission-oriented protection posture
		MOS	military occupation specialty

MOUT	military operations on urbanized terrain	OEG	operational exposure guide
MP	military police	OF	optional form
MPTP	Medical Proficiency Training Program	Ofc	office/officer
MRO	medical regulating officer	OIC	officer in charge
MS/MSC	Medical service Corps	OP	observation post
MSB	main support battalion	OPCON	operational control
MSE	mobile subscriber equipment	OPD	officer professional development
MSMC	main support medical company	OPLAN	operations plan
MSR	main supply route	OPORD	operations order
MTF	medical treatment facility	Opr	operator
MTOE	modified table of organization and equipment	OPSEC	operations security
Mtr	motor	OTSG	Office of The Surgeon General
NATO	North Atlantic Treaty Organization	PA	physicians' assistant
NBC	nuclear, biological, chemical	PCP	patient collecting point
MBCDE	nuclear, biological, chemical, and directed energy	PCs	permanent change of station
NCO	noncommissioned officer	PDR	Physician's Desk Reference
NCOIC	noncommissioned officer in charge	PHS	Public Health Service
NCOPD	noncommissioned officer professional development	PLL	prescribed load list
NCS	net control station	Plt	platoon
NP	neuropsychiatric	PMCS	preventive maintenance checks and services
NRTD	nonreturn to duty	POL	petroleum, oils, and lubricants
NTC	National Training Center	POV	privately owned vehicle
OACSI	Office for the Assistant Chief of Staff for Intelligence	PROFIS	professional officer filler system
OCONUS	outside of continental United States	PSYOPS	psychological operations
		PVNTMED	preventive medicine
		PZ	pick-up zone

R&S	reconnaissance and surveillance	SSN	social security number
RACO	rear area combat operations	STANAG	Standardization Agreement
Recon	reconnaissance	STI	statement of intelligence interest
RFL	restrictive fire line	STIR	scientific and technical intelligence register
RMSS	regional medical supply section	Surg	surgeon
RTD	return to duty	Svc	service
RTO	radiotelephone operator	SwBD	switchboard
S1	Adjutant (U.S. Army)	Tac	tactical
S2	Intelligence Officer (U.S. Army)	TAC CP	tactical command post
S3	Operations and Training Officer (U.S. Army)	TACCS	Tactical Army Combat Service Support (CSS) Computer System
S4	Supply Officer (U.S. Army)	TACP	tactical air control party
S&T	supply and transportation	Tailgate medicine	Procedure employed to retain maximum mobility during movement halts or to avoid the time and effort required to set up a formal, operational treatment facility (for example, during rapid advance and retrograde operations). Tailgate medicine consists of dispensing medications, bandaging and splinting, and performing simple emergency life sustaining procedures. It is performed at the "tailgate" of a vehicle using an easily reached set of medical supplies and equipment. Mobility of the unit is not affected; only three to five minutes are required to open or close this service.
SAR	search and rescue		
SB	supply bulletin		
SF	standard form		
Sgt	sergeant		
Sim	simulations		
SKO	sets, kits, and outfits		
SOI	security operations instructions		
SOP	standing operating procedure		
SPARK	systemic, pulmonary, and anaphylaxis resuscitative kit		
SPC	specialist (E4)	TAMMS	The Army Maintenance Management System
Spt	support	TASC	Training and Audiovisual Support Center
Sqd	squad		
Sqdn	squadron	TB	technical bulletin
SQT	skill qualification test	TB Tine	tuberculosis test

TC	training circular/track commander	UMCP	unit maintenance collection point
TDFS	terminal digit filing system	US	United States
TDY	temporary duty	USAF	United States Air Force
TF	task force	USAITAC	United States Army Intelligence and Threat Analysis Center
TIRS	terrain index reference system	USAMMA	United States Army Medical Materiel Agency
TM	technical manual	USAREUR	United States Army, Europe
TMC	troop medical clinic	Veh	vehicle
TO	theater of operations	WHO	World Health Organization
TOC	tactical operations center	WO	Warrant Officer
TOE	table of organization and equipment	WRAIR	Walter Reed Army Institute of Research
Trk	truck	XO	executive officer
TRMT	treatment		
(U)	unclassified		

REFERENCES

REQUIRED PUBLICATIONS: Required publications are sources that users must read in order to understand or to comply with this publication.		DEPARTMENT OF THE ARMY PAMPHLET (DA Pam)
		27-1 Treaties Governing Land Warfare
		27-10 Military Justice Handbook for the Trial Counsel and the Defense Counsel
		351-20 Army Correspondence Course Program Catalog
		600-8 Management and Administrative Procedures
		710-2-1 Using Unit Supply System (Manual Procedures)
ARMY REGULATIONS (AR)		
40-2	Army Medical Treatment Facilities: General Administration	
40-5	Preventive Medicine	
40-15	Medical Warning Tags and Emergency Identification Symbol	
40-26	Tuberculosis Detection and Control Program	
40-61	Medical Logistics Policies and Procedures	
40-66	Medical Record and Quality Assurance Administration	
40-501	Standards of Medical Fitness	
40-562	Immunizations and Chemoprophylaxis	
71-13	The Department of the Army Equipment Authorization and Usage Program	
350-1	Army Training	
350-41	Army Forces Training	
640-3	Identification Cards, Tags, and Badges	
710-2	Supply Policy Below the Wholesale Level	
750-1	Army Materiel Maintenance Policy and Retail Maintenance Operations	
		FIELD MANUAL (FM)
		1-102 Army Aviation in an NBC Environment
		3-3 Contamination Avoidance
		3-4 NBC Protection
		3-5 NBC Decontamination
		3-100 NBC Operations
		3-101 Chemical Staffs and Units
		3-106 Field Behavior of Biological Agents
		7-72 Light Infantry Battalion Task Force
		7-93 Long Range Surveillance Unit Operations
		8-9 NATO Handbook on the Medical Aspects of NBC Defensive Operations (AMed P-6)
		8-10 Health Service Support in a Theater of Operations

FM 8-10-4

8-10-8	Medical Intelligence in a Theater of Operations	25-5	Training for Mobilization and War
8-15	Medical Support in Divisions, separate Brigade, and Armored Cavalry Regiment	25-100 31-71	Training the Force Northern Operations
8-20	Health Service Support in the Combat Zone	63-1	Combat Service Support Operations—Separate Brigade
8-21	Health Service Support in the Comumunications Zone	63-2	Combat Service Support Operations—Division
8-35	Evacuation of the Sick and Wounded	63-2-2	Combat Service Support Operations: Armored, Mechanized and Motorized Divisions
8-40	Management of Skin Diseases in the Tropics at Unit Level	63-3	Combat Service Support Operations—Corps
8-50	Prevention and Medical Management of Laser Injuries	63-20	Forward Support Battalion
8-55	Planning for Health Service Support	63-21	Main Support Battalion, Armored, Mechanized, and Motorized Divisions (SPJ Main)
8-230	Medical Specialist	63-22	HHC and DMMC DISCOM, Armored, Mechanized, and Motorized Divisions
8-250	Preventive Medicine	71-2	Tank and Mechanized Infantry Battalion Task Force
8-285	Treatment of Chemical Agent Casualties and Conventional Military Chemical Injuries	71-3	Armored and Mechanized Infantry Brigade
10-14-2	Guide for the Battalion S4	71-100	Armored and Mechanized Division Operations
10-52	Field Water Supply	90-3	Desert Operations
17-95	Cavalry Operations	90-5	Jungle Operations
21-10	Field Hygiene and Sanitation	90-6	Mountain Operations
21-10-1	Unit Field Sanitation Team	90-10	Military Operations on Urbanized Terrain (MOUT)
21-11	First Aid for Soldiers	90-10-1 (HTP)	An Infantryman's Guide to Urban Combat (How to Fight)
25-2	Unit Training Management		
25-3	Training in Units		
25-4	How to Conduct Training Exercises		

References-2

90-11	Extreme Cold Weather	on medical supplies and equipment. See DA Pam 25-30 for complete list.
90-13	River Crossing Operations	
90-14	Rear Battle	

90-14 Rear Battle

100-5 Operations

100-10 Combat Service Support

100-15 Corps Operations

101-5 Staff Organizations and Functions

101-5-1 Operational Terms and Graphics

COMMON TABLE OF ALLOWANCES (CTA)

8-100	Army Medical Department Expendable/Durable Items
-------	--

PROJECTED REFERENCES: Projected publications are sources of additional information that are scheduled for printing but are not yet available. Upon print, they will be distributed automatically via pinpoint distribution. They may not be obtained from the USA AG Publications Center until indexed in DA Pamphlet 25-30.

TECHNICAL MANUAL (TM)

8-215 Nuclear Handbook for Medical Service Personnel

38-750 Army Equipment Record Procedures

38-750-1 The Army Maintenance Management System (TAMMS) Field Command Procedures

FIELD MANUALS (FM)

8-10	Health Service Support in a Theater of Operations
------	---

8-10-1	Health Service Support in Division, Separate Brigade, and Armored Cavalry Regiments
--------	---

8-10-3	Division Medical Operations Center-TTP
--------	--

TRAINING CIRCULAR (TC)

8-12 Use of the M51 Shelter System by Division Level Medical Units

8-10-5	Brigade and Division Surgeons' Handbook-TTP
--------	---

8-100 Expert Field Medical Badge Test

8-10-6	Medical Evacuation in a Theater of Operations-TTP
--------	---

SUPPLY BULLETIN (SB)

8-10-7	Health Service Support in an NBC Environment-TTP
--------	--

8-75-series These supply bulletins provide current listings and information

8-51	Combat Stress Control in a Theater of Operations
------	--

INDEX

- advance trauma management, 3-2*b*, 3-7*c*, 4-57, 4-59
- aid station
 - battalion, 1-20*e*, 2-8, 3-6*c*, 5-7, 5-15*b*, 5-21, 5-31*b*, 5-36, 5-37, 6-33*h*, *i*, App D
 - division artillery, 5-15*a*(1)
- AirLand Battle, 1-16
- Allied forces, support of, 4-3
- ambulance
 - exchange points, 4-18*c*, 4-62*b*, 5-10, 5-31*b*, 6-8, 6-20
 - platoon/section/squad, 3-7*b*, 4-18*c*, 4-24*b*, 4-62, 4-63, 4-72, 4-73, 5-9, 5-10, 6-36, 6-37, 6-39*c*, 6-39*d*
 - shuttle system, 4-19*c*(4), 6-39*c*(3)
- ammunition transfer point, 4-2
- antiarmor, 1-6*e*, 6-6*c*
- area support squad, 3-7*d*, 4-18*b*, 4-19*b*(2), 4-55, 4-57, 4-69, 5-2
- armored cavalry
 - health service support for, 2-5, 2-6, 2-7, 2-8
 - operational control of, 1-23*b*
 - organization of, 1-23*a*, 2-2, 2-3, 2-4
 - regiment, 2-1, 2-2, 2-3
 - squadron, 1-22, 1-23, 2-3, 2-4
 - troop, 1-23
- artillery
 - air defense, 1-12*a*(4), 1-21*c*, 2-2
 - division, 4-11, 5-1*c*, 5-15, 5-16*b*
 - field, 1-12*a*(4), 2-2, 5-1*c*, 5-15*a*(1)
 - fire support, 1-21*b*
- attacks
 - deliberate, 6-8*d*
 - exploitation, 6-8*e*
 - hasty, 6-8*c*
 - main, 6-5
 - sequence of, 6-3
 - supporting, 6-5
- automatic data processing, 4-2
- aviation
 - army, 2-2
- attack helicopter, 1-12*a*(4), 5-1*c*, 6-6*e*
 - maintenance support, 4-2, 4-5*b*,
 - reconnaissance squadron, 5-1*c*
- battalion
 - aid station, 1-20*e*, 2-8, 3-6*c*, 5-7, 5-11, 5-12, 5-21, 5-31*b*, 5-36, 5-37, 6-33*h*, *i*, App D
 - armor, 1-15, 5-1*c*
 - capabilities, 1-15*b*
 - coordinating staff, 1-19
 - forward support, 4-4*a*
 - health service support, 2-7, 2-8, 6-14, 6-20*b*, 6-24*c*, 6-25, 6-26, 6-27*c*, 6-33*j*
 - infantry, 1-14, 5-1*c*
 - main support, 4-13
 - maintenance, 4-45
 - maneuver, 3-7*c*
 - mechanized infantry, 1-15, 5-1*c*
 - medical, 4-25, 4-26, 4-27, 4-28, 4-34, 4-35, 5-2
 - mission, 1-15*a*
 - mortar platoon, 1-21*g*
 - special staff, 1-20
 - staff, 1-17, 1-18, 1-19, 1-20, 1-21
 - surgeon, 1-20*e*, 5-4, 5-21, 5-31
 - task force, 1-14*c*, 2-4, 4-3, 6-2, 6-8*b*, 6-11, 6-12, 6-16, 6-20, 6-21, 6-24
 - trains, 4-4*a*
 - types of, 1-14*b*, 5-1
- battle damage assessment and repair, 5-27*e*
- brigade
 - armored, 1-12
 - combat aviation, 1-12, 4-11
 - combat service support, 1-13*a*(3)
 - combat support, 1-13*a*(3), 5-1*c*
 - infantry, 1-13
 - mechanized, 1-12
 - medical, 3-3*f*
 - separate, 1-12*b*
 - support area, 4-4*a*, 4-11, 4-65*b*
 - surgeon, 5-17
- buddy aid, 3-5, 5-1, 6-39*c*(4)
- Class VIII supply, 3-5, 4-20, 4-65*d*, 5-9*c*, 5-25, 6-14*d*(3), 6-42
- cold injury, 5-39, 6-35*e*, *f*
- combat, 1-1

- combat electronic warfare, 1-12*a*(4)
- combat lifesaver, 2-8*c*, 3-5, 5-1*b*, 5-33, 6-39*c*(4), App B
- combat service support, 1-1, 2-4, 4-1, 4-2, 4-9, 6-6, 6-38
- combat stress control, 3-6*b*, 5-5*d*, 5-39
- combat support, 1-1, 4-3, 6-6, 6-38
- command and control, division support command, 4-10
- command post
 - development of, 4-3
 - division rear, 4-5*b*
 - division support command, 4-4*b*
 - task force, 6-8*b*(4)
- communications, 4-29, 4-40, 4-52, 4-56, 4-63, 4-66, 4-73, 5-7*b*, 5-10, 5-20, 5-21, 6-39*b*
 - command/operational net, 4-30, 4-32
 - forward support medical company, 4-33
 - long-range radio, 4-31
 - short-range radio, 4-32
- convoy, 5-35*e*
- corps support command, 1-12*b*, 4-4*b*
- diarrhea, 5-39
- directed energy, 6-40, 6-50
- disease and nonbattle injury, 3-2*a*, 5-39, 6-34*d*, 6-36*d*, *e*
 - prevention, 3-6*b*, 5-39, 6-34*d*, 6-36*d*, *e*
- division, 1-1,
 - air assault, 1-1, 1-7
 - airborne, 1-1, 1-6
 - armored, 1-1, 1-3
 - clearing station, 3-6*d*, 4-18*b*, 4-19*b*, 4-54, 4-56, 4-60, 4-61, 4-65, 4-67, 4-69, 4-71, 5-31
 - headquarters, 5-1*c*
 - health service support, 4-5*a*, 4-18*b*, 4-19*b*, 5-1*c*
 - infantry, 1-1, 1-4
 - light infantry, 1-1, 1-5, 5-1*c*
 - materiel management center, 4-4*b*(4), 4-6
 - mechanized, 1-1, 1-3
 - medical operations center, 4-4*b*(4), 4-15
 - medical supply office, 3-8*a*(4), 4-13*c*, 4-24*g*, 4-41
 - motorized, 1-1
 - rear command post, 4-5*b*
 - role, 1-2
 - staff, 1-8
 - support area, 4-4*b*, 4-11, 4-63, 4-65
 - support command, 1-12*a*(4), 4-1, 4-2, 4-5*a*, 4-9, 4-28, 4-43, 4-44, 4-65, 5-12, 5-25, 6-42
 - surgeon, 4-14, 4-37, 4-39,
 - trains area, 4-34
- drop zone, 6-20
- emergency medical treatment, 3-7*c*
- enemy prisoner of war, 6-16*c*, App H
- engineer combat support, 1-12*b*(1), 1-21*d*
- evacuation
 - air, 3-2, 3-6*d*, 4-19*c*, 4-23*c*, 4-71*d*, 5-11, 6-39*e*, 6-52*b*
 - ambulance squads, 3-7*b*
 - ground, 3-2, 3-6*d*, 4-17, 4-19*c*, 4-22, 4-23*c*, 4-71*d*, 5-7, 5-11, 5-15*d*, 5-16*g*, 5-37, 6-33*f*, 6-52*b*
 - litter teams, 6-33*f*, 6-33*i*, 6-39*c*(3)
 - nonmedical vehicles, use of, 3-6*d*, 4-19*c*(3), 5-9, 5-37*c*, 6-52*b*
 - request, App F
- far forward care, 3-6*c*
- field
 - medical card, 4-71*c*, 5-7*e*, 5-37*a*
 - medical treatment facility, 5-38
 - sanitation, 5-1, 5-15*a*(2), 5-39
 - sanitation team, 5-15*a*(3), 5-39*b*(2)
 - services, 4-5*a*
 - training exercise, 5-23
- flight surgeon, 5-17, 5-19
- food poisoning, 5-39
- forward
 - area support teams, 4-1*c*
 - edge of the battle area, 3-6*c*
 - line of own troops, 3-6*c*, 4-4*a*

- support battalion, 4-8, 4-13*b*
- support medical company, 3-5, 4-13*b*, 4-16, 4-18, 4-24*c*(2), 4-64, 4-65, 5-34
- garrison battalion aid station, 5-23
- Geneva Conventions, 6-16*c*, App H
- headquarters and headquarters company, 4-5, 4-12
- headquarters and support company, 4-28*a*, 4-34
- health record, 5-23
- health service support, 2-5, 2-7
 - challenge, 3-6
 - command, control, and communications, 3-6
 - Echelon I, 2-6*g*, 3-2*b*, 3-5, 3-7, 4-17, 4-22, 4-25, 4-27, 5-1, 6-14
 - Echelon II, 2-6*g*, 3-2*b*, 3-5, 3-7, 4-5*a*, 4-13, 4-16, 4-25, 4-27, 5-1
 - Echelon III, 3-2*b*, 3-5, 5-1
 - Echelon IV, 3-2*b*, 3-5
 - for offensive operations, 6-7, 6-8
 - major tenets of, 3-2*b*
 - mission, 3-2
 - nuclear, biological, and chemical environment, in, 6-41
 - operations, principles of, 3-3
 - planning, 3-6, 4-19, 5-31, 5-40, 6-7, 6-14*b*, 6-35*e*, 6-36, 6-41, 6-52*d*
 - reconstitution of units, 4-17
 - subordinate commands of, 4-11
 - system, 3-2, 3-4
- hearing protection, 5-39*b*
- heat injury, 5-39
- high frequency radio, 4-31
- immunizations, 5-26
 - administration of, 5-26*c*, 6-48*b*
 - record of, 5-26*b*
- individual protective measures, 5-39*b*
- intelligence
 - and electronic warfare, 1-12*a*(4)
 - medical, App C
 - military, 1-12*b*, 4-3, 4-38
- inventory, 5-24*b*(3)
- jungle rescue, 6-34*c*
- laboratory services, medical, 3-5, 4-17, 4-22, 4-51
- landing zone, 6-20*a*
- laser, 6-40*b*
 - protection, 6-40*b*
- leader, medical platoon, 3-7*c*, 3-8*a*(3), 4-19*a*, 6-8, 6-41*b*
- lessons learned, 5-40, App G
- litter
 - relay points, 6-33*i*
 - teams, 6-33*f*, 6-39*c*(3)
- load
 - authorized stockage list, 5-27*d*
 - plans, App D
 - prescribed list, 5-27*d*
- logistics support, 4-4*a*(2), 6-42
- low intensity conflict, 4-26*b*
- main
 - battle area, 2-1
 - support medical company, 3-5, 4-13, 4-21, 4-22, 4-23, 4-24
- maintenance
 - forms and records, 5-28
 - levels of, 5-27*c*
 - medical, 3-8*b*, 4-22, 4-23*e*, 4-65*e*
 - preventive, 5-22*f*(2)
 - unit, 1-19*e*, 4-45, 5-27, 5-28, 5-29
- maneuver, forms of, 6-4
- mass casualties, 2-8*c*, 4-18*b*, 5-9, 5-37*c*
- materiel management, 4-2
- medical
 - assemblage, 5-24
 - brigade, 3-3*f*
 - care, unit level, 3-6*c*
 - command, 3-3*f*
 - equipment repairer, 4-24*g*(2)

- equipment sets, 5-24
- group, 3-3*f*
- logistics battalion, 2-6*i*, 3-8*a*(4), 4-23*e*, 4-65*d*
- maintenance, 3-8*b*, 4-22, 4-23*e*, 4-65*e*
- modular support system, 3-2*b*, 3-7
- operations, 4-19, 5-16*f*
- operations officer, 4-24*a*(2)
- planning, 4-19*a*, 5-31*a*
- platoon, 2-8, 3-7*b*, *c*, 4-19*a*, 5-3, 5-5, 5-14, 5-21, 5-22, 5-34, 6-8
- section, 5-14, 5-15, 5-16, 5-19, 5-20
- specialist, 3-7*a*, 5-15*a*(3), 5-16*c*
- standby equipment program, 3-8*b*(2)
- supply, 3-8, 4-17, 4-20, 4-23*d*, 5-15, 5-25
- supply, optical, and maintenance unit, 2-6*i*, 3-8*a*(4), 4-23*e*, 4-65*d*
- support, 3-5
- threat, 5-39
- treatment squad, 3-7*c*

- medications, control of, 5-24*b*

- mental health, 3-5, 4-13*c*, 4-19*b*(5), 4-22, 4-24*e*, 4-49, 4-50, 4-53

- military operations on urbanized terrain, 6-39

- mission-oriented protection posture, 5-39*b*

- nonreturn to duty, 3-2*b*

- nuclear, biological, and chemical
 - alarms, 6-40*c*
 - civilian casualties, 6-45
 - collective protective, 6-40*c*, 6-44, 6-49
 - contamination, 4-19*b*(2), 4-71*c*
 - decontamination, 4-71*c*, 5-7*e*, 6-43, 6-48, 6-52
 - environment, 6-40, 6-46, 6-48, 6-49
 - health service support in, 6-41, 6-43, 6-44, 6-46, App E
 - mission-oriented protection posture, 6-49
 - operational exposure guide, 1-20*b*
 - operations, 4-66, 5-7*e*, 6-40
 - patient evacuation in, 6-52
 - patients, 4-19*b*(2), 4-71*c*, 6-43, 6-48*c*, 6-49*b*, *d*, App E
 - personnel, 1-20*b*

- operational control, 6-31*c*

- operations
 - breakout, 6-29
 - cold weather, 6-35, 6-51*b*
 - conduct of, 6-8
 - defensive, 6-9, 6-10, 6-11, 6-12, 6-13
 - desert, 6-36, 6-51*d*
 - guard, 6-31
 - health service support for, 6-7, 6-8, 6-14, 6-16*c*, 6-23, 6-24, 6-26, 6-27, 6-28, 6-29*c*, 6-30*c*, 6-31*d*, 6-33, 6-34*b*, *c*, 6-35, 6-36, 6-37*c*, 6-38*c*, 6-39*b*
 - jungle, 6-34, 6-51*c*
 - linkup, 6-30
 - mountain, 6-33, 6-51*a*
 - offensive, types of, 6-1, 6-2, 6-8
 - orders, 5-31, 5-34
 - passage of lines, 6-27
 - plan, 5-31
 - rear, 6-11*e*, 6-20
 - rear and area damage control, 6-38
 - relief, 6-28
 - Reserve, 6-11*d*, 6-15, 6-16
 - retrograde, 6-21
 - delay, 6-22, 6-24
 - retirement, 6-22, 6-26
 - withdrawal, 6-22, 6-25
 - river crossing, 6-37
 - special, 6-51
 - synchronization of, 6-6
 - urbanized terrain, on, 6-39

- orders
 - fragmentation, 6-8*c*
 - operations, 5-31, 5-34

- patient
 - abandonment, 2-8*c*
 - collection points, 3-6*d*, 6-39*c*
 - decontamination, 5-7*e*
 - holding, 3-5, 3-7*e*, 4-18*b*, 4-22, 4-23, 4-27, 4-51, 4-58, 4-65*b*, 5-7*g*
 - treat, 5-37

- personal hygiene, 5-1*b*, 6-48*b*

- pest management, 5-39*b*(2)

- pharmacy, 4-22

- physicians' assistant, 3-7*c*, 4-19*b*(2), 5-22*e*(3)

- plans
 - health service support, 3-6, 4-19, 4-38, 5-40, 6-23c, 6-24c
 - load, 5-35c, d, App D
- platoon
 - ambulance, 4-18c, 4-24b, 4-62, 4-63
 - deployment, 5-35
 - medical, 5-3, 5-5, 5-21, 5-22, 6-41b
 - treatment, 4-53, 4-67
- preventive medicine, 3-5, 3-6b, 4-13, 4-19b, 4-22, 4-24f, 4-46, 4-47, 5-39, 6-34d, 6-42c
- property exchange, 5-13
- radiation dose, 6-47
- radio
 - high frequency, 4-31
 - long-range, 4-31
 - short-range, 4-32
- radiology services (x-ray), 3-5, 4-17, 4-19b(2), 4-22, 4-51
- reconstitution of health service support units, 4-17
- records
 - Field Medical Card, 4-71c
 - health, 5-23b
- regiment, 2-1, 2-2, 2-3
 - medical supply section, 2-6i
- repellent, arthropod, 5-39b, 6-48b
- return to duty, 3-2, 3-6d
- security operations instructions, 4-40
- self-aid, 3-5, 5-1
- sets, kits, and outfits, 5-24
- sick call, 5-23b
- signal, forward area platoon, 1-12a(4)
- squadron
 - combat aviation, 5-17, 5-19
 - reconnaissance, 5-1c, 5-19
 - surgeon, 5-31
- supply
 - Class VIII, 3-5, 5-12
 - flow of, 3-8a(4), 5-12
 - point, 3-8a(4)
 - property exchange, 5-13, 5-15f
 - request for, 3-8a(4), 5-12
 - Reserve, 4-2
 - support for, 3-5, 3-8, 4-2, 5-12
- support company, 4-51, 4-52
- surgeon
 - battalion, 1-20e, 5-4, 5-21, 5-31
 - brigade, 5-17
 - division, 4-14, 4-37, 4-39
 - division artillery, 5-15a(1)
 - flight, 5-17, 5-19
 - squadron, 5-31
- surgical detachment, 3-7f
- tactical
 - air control party, 1-12a(4)
 - army combat service support (CSS) comp system, 4-31
 - operations, 1-1
- tailgate medicine, 4-25
- training, 5-30, App A
 - mission essential tasklist, 5-30f
 - medical platoon, 5-30h(3), App A
 - expert field medical badge, for, 5-30i
 - medical, in field, 5-40
- tanks, 6-6a
- treatment
 - emergency medical, 3-7c
 - facility, field medical, 5-38
 - platoon, 4-24c
 - squad, 3-7c, 4-57, 4-59, 4-60, 4-70, 5-6
 - team, 4-56, 5-15
 - trauma teams, 3-7c
 - vehicles, 3-7c, 4-60
- triage, 4-59, 5-9b(1), 6-47, 6-49c
- troop
 - armored cavalry, 1-12b
 - medical clinic, 5-23b

United States

Air Force, 1-6c, 1-12a(4)

Army Medical Materiel Agency, 3-8b(2)

vehicles

ambulance squad, 5-1d, 5-9d

treatment squad, 5-1d, 5-15b, 5-16e

veterinary services, 3-6

vision protection, 5-39b

water

potable distribution, 4-2, 5-39b, 6-36d

requirements, 5-39b

treatment, 5-39b, 6-36d

By Order of the Secretary of the Army:

CARL E. VUONO
General, United States Army
Chief of Staff

Official:

THOMAS F. SIKORA
Brigadier General, United States Army
The Adjutant General

DISTRIBUTION:

Active Army, USAR, and ARNG: To be distributed in accordance with DA Form 12-11-E, requirements for FM 8-10-4, Medical Platoon Leaders' Handbook-Tactics, Techniques, and Procedures (Qty rqr block no. 4897), FM 8-15, Medical Support in Divisions, Separate Brigades, and the Armored Cavalry Regiment (Qty rqr block no. 0816).